

AD 69 4646

# DIGITAL COMPUTER NEWSLETTER

The purpose of this newsletter is to provide a medium for the exchange of information concerning recent developments in digital computer projects. Distribution is limited to government agencies, contractors, and contributors.

OFFICE OF NAVAL RESEARCH • MATHEMATICAL SCIENCES DIVISION

Vol. 17, No. 4

Gordon D. Goldstein, Editor  
Margo A. Sass, Associate Editor  
Yvonne H. Kilgore, Editorial Assistant  
Elaine K. Strohl, Editorial Assistant

October 1965

## CONTENTS

	Page No.
<b>EDITORIAL POLICY NOTICES</b>	
1. Editorial	1
2. Contributions	1
3. Circulation	1
<b>COMPUTERS AND DATA PROCESSING, NORTH AMERICA</b>	
1. Advanced Scientific Instruments, Division of Electro-Mechanical Research, Advance 6050, 6070, and 6080 Systems, Minneapolis, Minnesota	2
2. Airborne Instruments Laboratory, Division of Cutler-Hammer, 902 Numerical Control System, Deer Park, New York 11729	2
3. Burroughs Corporation, B8500 Data Processing System, Detroit, Michigan 48232	5
4. Honeywell, Inc., H-8200, Wellesley, Massachusetts	6
5. Univac Division, Sperry Rand Corporation, Univac 1830 Military Computer, New York 19, N. Y.	9
<b>COMPUTING CENTERS</b>	
1. Continental Airlines, Management Information System, Los Angeles, California 90009	11
2. University of Illinois, Department of Computer Science, ALCOR ILLINOIS 7040/7090 Compilers, Urbana, Illinois 61803	12
3. The University of Iowa, Data Reduction for Explorer XXV, Iowa City, Iowa 52240	12
4. University of Kentucky, Computing Center, Analog Simulation on the 7040, Lexington, Kentucky 40506	13
5. Office of Naval Research, Navy Automated Research and Development Information System (NARDIS), Washington, D. C. 20360	13
6. New York University, Courant Institute of Mathematical Sciences, Control Data 6800, New York, N. Y.	15
7. University of Southern California, Hybrid Computer System, Los Angeles, California	15
8. Tulane University, Computer Laboratory, New Orleans, Louisiana 70118	16
<b>COMPUTERS AND CENTERS, OVERSEAS</b>	
1. Aachen Technical University, Control Data 6400 Computer, Aachen, Germany	17
2. Electrologica, EL WICOMATIC, Den Haag, Netherlands	17
3. Elliott-Automation Computers Limited, Internal Re-organization, London W1, England	19
4. Elliott Brothers Limited, Scientific Computing Division, NCR Elliott 4100 Computer, Borehamwood, Hertfordshire, England	19
5. Université de Liège, Centre de Calcul et de Traitement de L'information, DOCEO, Adaptive Teaching System, Liège, France	24
6. The University of Liverpool, Department of Applied Mathematics, Computer Laboratory, Liverpool 3, England	25
7. Oxford University, Computing Laboratory, Oxford, England	25
<b>MISCELLANEOUS</b>	
1. American Stock Exchange, Automation Plans, New York, N. Y. 10006	26
2. Bell Telephone Laboratories, Long Distance Error Control, 463 West Street, New York 14, N. Y.	28
3. Bryant Computer Products, Division of EX-CELLO Corporation, PhD-170 Random-Access Memory, Walled Lake, Michigan 48088	29
4. Carnegie Institute of Technology, Philco Visual Display System, Pittsburgh, Pennsylvania 15134	30
5. Control Data Corporation, CONSTRUCTS, Computer-Directed Drawing System, Minneapolis, Minnesota 55440	31
6. Control Data Corporation, Traffic Surveillance System, Minneapolis, Minnesota 55440	32
7. University of Illinois, Coordinated Science Laboratory, PLATO II and III, Urbana, Illinois	38
8. Jefferson Medical College Hospital, Patient Account System, Philadelphia, Pennsylvania 19107	39
9. University of Kentucky, Computing Center, Lexington, Kentucky 40506	40
10. University of Louisville, Computer-Aided Instruction, Louisville, Kentucky	41
11. University of Michigan, Time Sharing System, Ann Arbor, Michigan	41
12. University of Missouri, Medical Center, Automated Laboratory Data Handling, Columbia, Missouri	43
13. National Bureau of Standards, MAGIC, Washington, D. C.	46

This document has been approved for public release and sale; its distribution is unlimited.

D D C  
OCT 16 1965

Approved by  
The Under Secretary of the Navy  
25 September 1965

NAVSO P-645

Reproduced by the  
CLEARINGHOUSE  
for Federal Scientific & Technical  
Information Springfield Va. 22151

48

## Editorial Policy Notices

### EDITORIAL

The Digital Computer Newsletter, although a Department of the Navy publication, is not restricted to the publication of Navy-originated material. The Office of Naval Research welcomes contributions to the Newsletter from any source. The Newsletter is subjected to certain limitations in size which prevent publishing all the material received. However, items which are not printed are kept on file and are made available to interested personnel within the Government.

DCN is published quarterly (January, April, July, and October). Material for specific issues must be received by the editor at least three months in advance.

It is to be noted that the publication of information pertaining to commercial products does not, in any way, imply Navy approval of those products, nor does it mean that Navy vouches for the accuracy of the statements made by the various contributors. The information contained herein is to be considered only as being representative of the state-of-the-art and not as the sole product or technique available.

### CONTRIBUTIONS

The Office of Naval Research welcomes contributions to the Newsletter from any source. Your contributions will provide assistance in improving the contents of the publication, thereby making it an even better medium for the exchange of information between government laboratories, academic institutions, and industry. It is hoped that the readers will participate to an even greater extent than in the past in transmitting technical material and suggestions to

the editor for future issues. Material for specific issues must be received by the editor at least three months in advance. It is often impossible for the editor, because of limited time and personnel, to acknowledge individually all material received.

### CIRCULATION

The Newsletter is distributed, without charge, to interested military and government agencies, to contractors for the Federal Government, and to contributors of material for publication.

For many years, in addition to the ONR initial distribution, the Newsletter was reprinted by the Association for Computing Machinery as a supplement to their Journal and, more recently, as a supplement to their Communications. The Association decided that their Communications could better serve its members by concentrating on ACM editorial material. Accordingly, effective with the combined January-April 1961 issue, the Newsletter became available only by direct distribution from the Office of Naval Research.

Requests to receive the Newsletter regularly should be submitted to the editor. Contractors of the Federal Government should reference applicable contracts in their requests.

All communications pertaining to the Newsletter should be addressed to:

GORDON D. GOLDSTEIN, Editor  
Digital Computer Newsletter  
Informations Systems Branch  
Office of Naval Research  
Washington, D. C. 20360

## Computers and Data Processors, North America

### Advance 6050, 6070, and 6080 Systems

*Advanced Scientific Instruments  
Division of Electro-Mechanical Research, Inc.  
Minneapolis, Minnesota*

Advanced Scientific Instruments announces the development of three new computer systems. The new systems—Advance 6050, 6070, and 6080—expand the Advance Series product line to five systems. Other members of the family introduced 6 months ago by ASI are the Advance 6020 and 6040.

The new units directly support ASI's objective of providing machines with the highest system productivity in their class, for the customers they serve. The new machines provide both specialized hardware in some of the targeted customer areas, such as the 6070 for seismic data processing, as well as in general hardware such as the floating-point 6050, which offers increased productivity in all scientific and engineering fields. The time-sharing features in the 6080 are among the most advanced and powerful yet announced and should have great value to customers considering this mode of operation. With these products, ASI is taking another step to solidify its position in the computer industry. ASI's new systems are entirely modular in concept and feature expanded processing capabilities. All systems are upward program compatible.

The Advance 6050 system includes such features as double precision floating point hardware with floating point multiply execution times of 17.1 microseconds and floating point divide

times of 28.5 microseconds. Input/output access directly to the arithmetic section as well as to memory is also featured.

The Advance 6070 system is designed for the rapidly expanding systems market. Multi-processing capability is provided by a very high-speed arithmetic processor, in addition to the standard processor. Arithmetic operations are accomplished independently of, and simultaneously with, the main processor. System capability can be further expanded by the addition of auxiliary processors. Some sample processing times are: sine, 42 microseconds; square root, 48 microseconds; and arctan, 70 microseconds.

The Advance 6080 system is designed for time-shared operations, multi-programming capability, and the use of remote stations. Features include memory protect by either hardware or software control and hardware relocation.

All systems include the latest innovations in monolithic integrated circuitry. Memory size can be expanded up to 32,000 words; word length is 24 bits plus parity. A wide choice of peripheral options is available. Prices start at \$104,000 for the basic Advance 6050 system and range upward according to configuration specified. Prices for the Advance 6070 begin at \$132,000; prices for the Advance 6080 start at approximately \$150,000.

### 902 Numerical Control System

*Airborne Instruments Laboratory  
Division of Cutler-Hammer  
Deer Park, New York 11729*

Cutler-Hammer's AIL Division, Deer Park, New York, announced in June the receipt of an initial contract for 10 numerical control systems for use with the Wiedematic Turret Punch Press manufactured by the Wiedemann Division of Warner & Swasey Company.

Designed from the ground up for maximum efficiency in the numerical control of turret punch presses, Cutler-Hammer's new Model 902 Numerical Control System provides features of particular interest to sheet-metal jobbing shops. An auxiliary tape reader is incorporated into

the design of the system to provide the system with a reliable low-cost "memory" that increases the productivity of the machine, and simplifies programing for repetitive hole patterns. The time required to prepare a tape by conventional means is reduced by a factor of 15 where repetitive hole patterns are called for. Tape checking and first-piece inspection times are similarly reduced, and a computer is not required to use the system at full efficiency.

The production capability of the machine is further enhanced by the availability of a library of ready-made computer-prepared programs for the second tape reader that enable the machine to punch large circular holes at high speed. These holes are "ribbled" by a standard round punch at speeds better than 100 "hits" per minute. These ready-made tapes cover a wide choice of hole diameter/punch diameter combinations and provide a range of from 24 to 120 "hits" per circle. Convenient graphical means let the programmer easily determine the particular hit schedule best adapted to his particular requirements. Circular holes of any diameter within range of the work piece can be produced on a Wiedemann Turret Punch Press.

Control resolution of the system is 0.001 inch, with the machine/control combination providing X and Y piercing accuracies of  $\pm 0.004$  inch at positioning speeds of 1000 inches per minute simultaneously in both axes. The hit rate is 70 per minute for moves of 3 inches in both axes, exclusive of turret indexing. For shorter moves, hit rates over 115 per minute can be achieved.

The control system is fully transistorized and uses modular plug-in construction to simplify servicing and minimize the on-the-job stocking of replacement components. Built-in trouble-shooting indicators reduce the time required for diagnosis and front-accessible test points on the logic modules aid the maintenance man in trouble-shooting.

Cutler-Hammer Model 902 Numerical Control System for the Wiedematic Turret Punch Press is a fully transistorized system that controls the two orthogonal machine axes, the turret selection and the initiation of the punching cycle. Housed in a cabinet occupying a floor space only 4 feet by 2 feet, the new Model 902 provides all the electrical controls for the machine and is equipped with a sloping front panel at convenient height for fast fool-proof operation. Fully gasketed construction ensures a favorable environment for the tape readers, that is, both dust- and oil-tight. Internally generated heat is minimized; no air conditioning is required in normal shop environments.

The control system is of the absolute type with each position dimensioned with respect to an absolute zero position reference.

The control input is provided by standard 1-inch, 8-track, punched tape in accordance with EIA Standard RS-227; character coding is in accordance with EIA Standard RS-244. Word address format is used in accordance with EIA Standard RS-273. For programed dimension of table position and the turret selection number is preceded on the tape by a coded address. This format provides advantages in simplifying programing and tape preparation since any data which does not change in a succeeding block need not be repeated on the tape. Five-digit input (99.999) is standard. A six-digit input system is optionally available for machines with larger table movements. Full-range positive and negative dimensions are programable. Dimensions are given in inches and are assumed to be positive unless prefixed by a minus sign. Trailing zeros can be omitted. Turret rotation is clockwise for positive turret commands and counter-clockwise for negative commands.

Full-range zero offset capability is provided. Zero offsets may be inserted manually by front panel controls, or automatically from tape commands. The tape-controlled zero offset capability permits a second tape reader to be used profitably as a low-cost memory. Repetitive hold patterns or hit programs can be punched on one tape, and the entire program repeated at intervals determined by the tape offset commands in the tape on the other reader.

The first numerical control system using two tape readers was installed in late 1964 and has been working a 20-hour day ever since. Many advantages, both direct and indirect, accrue to the user of this new control system. Simplified programing, shorter tapes, reduced inspection, and significant manufacturing economies have been achieved. The cost savings resulting from the two-tape reader method depend on shop practice and product mix. The economic advantages increase markedly as the number of lots of relatively large quantities increases. Variations in lot size from one run to another, maybe weeks later, can be readily accommodated by the inherent flexibility that the second tape reader provides.

The operation of the two-tape reader system can be briefly described as follows: the hole pattern is programed only once and punched on a tape for tape reader "A." A series of "zero offsets" is programed on another tape for use in tape reader "B." A signal coded in the tape transfers the positioning control from one

tape reader to the other as required. The full-range zero offset capability in the basic control system permits the second tape reader to select a zero offset in "X" or "Y" or both so that the basic hole pattern, as programed on tape "A," can be repeated at the programed spacing over a large sheet of stock. The zero offset between adjacent parts is programed with proper consideration of bend and shear allowances. By use of the two tape readers, the machine punches one complete hole pattern, switches to the "B" tape reader, offsets itself to the next part location, switches back to the "A" tape reader and repeats the pattern. When the full number of patterns has been completed, the stock is removed and sheared into strips along one axis. Individual pieces are then sheared from each strip.

Control of the table movement is through high-response hydraulic servovalves for fast table motions and high positioning accuracy. An INDUCTOSYN<sup>(TM)</sup> and resolvers provide position feedback on each axis. A precision tachometer geared to each axis provides velocity feedback for absolute servo stability and high accuracy positioning without overshoot. System damping is adjustable so that smooth control can easily be achieved, and the system adjusted for long-term changes in machine characteristics.

The cabinet houses both the control system components (except for the machine-mounted servo components) and all the machine electrical starters and controls. Centralizing the control functions in a single cabinet simplified installation and improves maintainability.

All controls and indicators for the machine/control combination are mounted on an operator's control station on the front of the cabinet, slanted at an angle for good visibility, and conveniently located for operation.

#### MODES OF OPERATION

The control provides four standard modes of operation:

##### TAPE-AUTOMATIC

This is the fully automatic mode in which all table motions, turret motions and auxiliary functions are performed in accordance with punched data in the tape. Pressing the START button initiates the reading of the first block on the tape. Table movement and turret indexing then occur simultaneously. When both table and turrets have reached position, the punch cycle

is tripped. During the punching operation, the tape reader automatically reads the next block of information. When the punch is clear, the table moves to the next programmed portion and the turrets index to the next punch. The punch cycle is tripped, the next tape block is read and the operation continues in similar fashion until the stop at the end of the tape program.

##### TAPE - SEMI-AUTOMATIC

In this mode, the operator brings the machine to the position called for on the tape by pushing the "CYCLE START" button. After positioning, the press must be tripped by manual command. By repeating the above sequence, the operator will cause the next block of information to be read, the work positioned and the press tripped.

##### DIAL INPUT

Dial Input mode permits the operator to insert commands for a discrete table position (either x or y axis or both) and/or turret position by the operation of thumbwheel switches. These instructions will then be carried out by automatic control. The press must be tripped by manual command.

##### MANUAL OPERATION

This mode permits the operator to position the table or turrets to any position by manual operation of job buttons and selector switches.

#### SPECIFICATIONS

##### CONTROL

Type:	Point-to-point positioning, absolute
Resolution:	0.001 inch
x-axis motion:	± 98.999 inch
y-axis motion:	± 98.999 inch
Turret positions:	Up to 36
Miscellaneous functions:	m00, m02, m03, m06 The control system is arranged so that additional miscellaneous functions m01, m04, m05, m07, m08 and m09 may be added later.

**SPECIFICATIONS Cont.**

**DATA INPUT**

**Tape input:** One inch 8-track Perforated Tape in accordance with EIA Standard RS-227

**Character coding:** BCD in accordance with EIA Standard RS-244

**Format:** Word Address, Variable Block, in accordance with EIA Standard RS-273

**Format detail:**  $x \pm 23y \pm 23t \pm 2m2^*$

- where:**
- x = cross motion coordinate
  - y = in and out motion coordinate
  - t = turret selection
  - m = miscellaneous function
  - \* = End of Block character (Flexowriter-Carriage Return)

**Tape Reader:** 300-character/sec photoelectric punched tape reader

**PERFORMANCE SPECIFICATIONS**

**Positioning Speed - Max.** 1000 in/min  $\pm$  10%

**Acceleration - Max.** 125 in/sec<sup>2</sup>

**Deceleration - Max.** 125 in/sec<sup>2</sup>

**Control Positioning Accuracy:**  $\pm$  0.001 inch

**Production Rate:** 65 hits/min on A-30 machine

70 hits/min on A-15 machine

(Assuming 3-inch moves on both axes and no turret changes)

**B8500 Data Processing System**  
*Burroughs Corporation*  
 Detroit, Michigan 48232

Burroughs Corporation, in June, announced the B8500 modular data processing system, a large scale electronic computer with monolithic integrated circuitry and total thin film memory offering logic speeds in billionths of a second. The B8500 is aimed at extremely high volume, high speed, time sharing, real time applications. Because of its modularity, it is capable of expansion into a system larger than any other computer now available or announced. The B8500 has the versatility and power to handle both business and scientific problems of any complexity.

Because of the wide variety of configurations possible with the B8500, pricing of an individual system will depend upon the results of a system analysis to determine a user's needs, and will range approximately from \$5 to \$15 million, Eppert said.

The B8500's speed, flexibility for growth and modification, modular software and its multi-

processing and time sharing capabilities make it ideal as a centralized computation and communications center replacing multi-computer installations. It also makes practical a very high level of work-per-dollar. In addition, the system's versatility and reliability make the B8500 extremely valuable in military command and control applications.

The system has been proposed for a number of commercial and governmental applications and is available on a built-to-order basis.

The B8500 will be built and marketed through the Defense and Space and Special Systems Group headquartered in Paoli, Pa. This organization, formerly the Defense and Space Group, has been given its new name to reflect the increasing degree to which large computer and communication systems are finding use in commercial or special applications outside the defense and space field, Eppert added.

The B8500 is the culmination of a 6-year development program which has seen Burroughs concepts of modularity, multiprocessing, time sharing and software proved in experience by

the B5500 Information Processing System and the D800 Series Modular Data Processing System in government, commercial and military applications.

## H-8200

Honeywell Inc.  
Wellesley, Massachusetts

Honeywell's electronic data processing division has moved further into the "third-generation" with the introduction of a new large-scale computer using advanced microcircuitry throughout.

The Honeywell 8200 combines key characteristics of the firm's two top computer lines into a single machine able to process nine separate programs at the same time. The new computer, designed for mixed business, scientific, and real-time data processing, can operate on both "word-" and "character-oriented" programs. It also has full data and programming compatibility with Honeywell's Series 200 and Series 800 computers.

The entire H-8200 central processor, including logic, arithmetic, and control sections, will occupy less than 8 cubic feet, it was said.

### SHARES MEMORY

Memory and input/output protection features, plus extensive interrupt capabilities, make the H-8200 extremely attractive for time-sharing applications. The H-8200 can share memory among the equivalent of 10 central processor groups (multi-processing); run nine programs at once (parallel processing); and have more than one "live" program controlled by a single processor group (multi-programming). More than 3000 remote stations can share time simultaneously.

The H-8200 will provide new users with a highly adaptable system able to perform these advanced activities as part of a standard data processing installation, while at the same time providing uninterrupted growth for current users of nine computer models that comprise Honeywell's Series 200, 400, and 800 systems (H-120, H-200, H-1200, H-2200, H-4200; H-400; H-1400; H-800, and H-1800).

### SYSTEM DESCRIPTION

The H-8200 contains three major subsystems: processor, memory, and input/output.

The processor has within it 10 programming groups: nine running active programs and a tenth, called the master control group, monitoring the entire computer. Eight of the active programming groups handle data and instructions in the form of fixed-length words. The ninth active programming group handles data and instructions in the form of discrete variable-length characters. The master control group provides intercommunication among all active programming groups. The processor also includes console, display, and manual control facilities.

The memory subsystem has one to eight memory modules and a memory multiplexor (MM). Each module holds 131,072 characters (16,384 words) for a total maximum core storage capacity of 1,048,576 characters (131,072 words). Memory cycle time is 750 nanoseconds per eight-character word.

This speed and capacity, in addition to a high computational rate, makes possible a basic data transfer rate to peripheral devices of 1.33 million characters a second.

The MM, to provide maximum memory utilization, can access up to three memory modules during each cycle. It handles and routes multiple requests for access to memory, assigns priorities, resolves conflicting requests, and provides memory barricade control so that one active program will not disturb operation of another.

The input/output subsystem comprises an input/output multiplexor (I/OM) and up to 32 read/write channels. Up to 48 peripheral control units and their associated devices can be connected to the subsystem; enabling the H-8200 to operate up to 32 peripheral devices simultaneously. The I/OM continuously scans all peripheral control units connected to the system and requests time from memory whenever a data transfer is to take place.

In a time-sharing or data communications application, for example, each control unit can be linked to a 64-line communications device

for a total of 3072 remote connections. Access to the H-8200 will, in effect, be instantaneous from the standpoint of the remote communications devices.

The I/OM contains hardware which enables the program-assignable read/write channels to "float" among the peripheral devices connected to the system. Any peripheral device is available for either word- or character-oriented programs.

The I/OM will accept input from or provide output to any standard peripheral device in the Series 200 line and major peripheral devices of the Series 800 line. Devices include Honeywell's magnetic tape drives, line printers, card readers and punches, random access memory storage devices, and data communication controls and terminals.

#### MASTER CONTROL GROUP

The master control group coordinates actions of all other groups and subsystems. It automatically allocates and protects memory and peripheral devices; issues peripheral orders; diagnoses program and barricade violations and improper orders; sets or alters privileged control functions; and diagnoses machine malfunctions.

#### H-8200 OPERATION

Operation of the H-8200 may be understood as a series of coordinated requests for access to memory. Requests may come to the MM from word- or character-oriented programming groups, or from the I/OM. The I/OM has priority and may request memory cycles from the MM as needed.

The link between the three subsystems is the master control group. Each type of processing (word, character, or peripheral) may signal the master control group that it wants access to another type. The master group will monitor the request for validity, availability, and protection status. If all tests are passed, the master control group will provide access to the appropriate facility and make itself available for the next request.

In input processing, the I/OM will collect data from the peripheral device and place it in memory. For output processing, the I/OM will duplicate the data and send it to the appropriate peripheral device.

#### TIME SHARING

The H-8200's time-sharing ability is made possible by assigning a protection identification tag to each word-oriented programming group and three such tags to the character-oriented group. Tags can be set or changed only by the master control group. Each 512-word (4096-character) block of memory also has a tag.

When a memory access is requested by any source, the MM compares the source's tag with the tag of the requested portion of memory. Access is granted if the tags agree. The master control group is signalled to take action when they do not. The I/OM retains tags assigned by any programming group issuing a peripheral order. When the master control group is requested to perform such an order, the tag of the requesting group is made available to it. The master control group then checks the tag with the I/OM to determine if the programming group is allowed to use the peripheral device requested.

Each channel in the I/OM also has a reservation ability which can be set or removed only by the master control group on behalf of a particular program; making the channel appear "busy" to all other programs. This feature is designed for use in real-time applications to guarantee channel availability. Each channel also contains other status information, including the programming group for which its current operations are being performed and that program's protection tag.

#### INTERRUPT PROCESSING

Peripheral devices can interrupt the H-8200 via the character-oriented programming group, which has three levels of operation: normal mode, internal interrupt mode and external interrupt mode.

The H-8200, with this ability, achieves two types of parallel processing: word-oriented programming groups automatically execute a string of orders in each active program group; while the character-oriented programming group can instruct one program to use as many cycles as it needs and then allocate its remaining cycles to a lower-priority program. The master control group controls interaction between the two types of processing.

#### DATA HANDLING

The eight programming groups using fixed-length words for data and instructions operate



in parallel in a manner similar to the H-800 and H-1800: all eight can be active simultaneously. Each memory cycle used by these groups transfers eight characters at one time in the form of a word. Instruction formats and definitions are completely compatible with the H-800 and H-1800. Each group has 32 18-bit control registers.

The variable-length character processing group operates serially. Instruction formats and definitions are completely compatible with those in the Series 200 systems. This group has 64 21-bit control registers.

## PROGRAMMING

The H-8200 offers two powerful programming languages to new users of Honeywell computer systems; continuity of programming to current users of Honeywell's Series 200 and Series 800 systems; and the ability to automatically translate into Series 200 language, using the Liberator technique, programs originally written for six competitive computer systems. Also able to grow into the H-8200 will be users of Honeywell's 400 and 1400 computer systems, for whom a program translator is being designed to enable automatic conversion of H-400/1400 programs into Series 200 language.

Word-oriented programs of Series 800 systems with 5 years of field-proven experience—use three-address instructions; provide binary, decimal or floating-point arithmetic; masking operations that enable packing or unpacking of data words or instructions; and direct, indirect and indexed addressing.

H-8200 programming aids include the ARGUS assembly system; COBOL; a FORTRAN IV scientific compiler; PERT; and ALPS (an automatic linear programming system). ARGUS, in addition to the programming language and assembly program, has monitoring routines for serial and parallel processing, up-dating and test programs, sort and collate programs, an extensive library of other frequently-used business and scientific routines, and tape input/output, and report editor routines.

Character-oriented programs of Series 200, in full field use for the past year, make available to the H-8200 user all instructions needed for arithmetic, logical, control, editing, and input/output functions. Scientific options are available in Series 200 programs, also.

Included in Series 200 programs are instructions for handling peripheral and commu-

nication interrupts, both valuable in time-sharing and real-time applications.

In addition to Easycode, the standard Series 200 programming language, the user has available both COBOL and FORTRAN and generalized data manipulation programs.

## LIBERATOR

The Liberator technique, a unique Honeywell computer feature first introduced with the Series 200 systems, enables users of a number of older, competitive systems to update their data processing capabilities without the cost of complete reprogramming or personnel retraining. Programs originally written for the 1401, 1401-G, 1440, 1480, 1410, and 7010 computers can be automatically and quickly translated into Series 200 programs. This is accomplished through a one-time conversion of the competitive programming languages and data formats.

## FULLY INTEGRATED

The H-8200 uses monolithic integrated circuitry in its logic elements and hybrid circuitry in its memory elements for maximum density, speed, and reliability.

Arithmetic, logic and input/output control sections have High-Level Transistor-Transistor Logic (HLTTL) integrated circuits throughout. Honeywell has developed custom HLTTL circuits having high-speed performance at one-quarter the power levels of other integrated circuits of comparable performance. Speeds average 5 nanoseconds per logic level. Central processor, I/OM and MM will occupy less than 8 cubic feet.

Memory circuits use ceramic-based hybrid circuitry to provide increased speed and compactness. This circuitry, used with tiny (20 mil) ferrite cores, provides a size reduction of four-to-one over discrete-component memory units. A one-million-character memory, for example, fits into approximately eight modules, each approximately 4 cubic feet in size.

## SPECIFICATIONS AND PRICES

### Main Memory:

Capacity (characters)	131,072 to 1,048,576 characters
Capacity (words)	16,384 to 131,072 words
Access time	375 nanoseconds
Cycle time	750 nanoseconds

**SPECIFICATIONS AND PRICES cont.**

<b>Additional Main Memory:</b>	One increment of 131,072 characters (16,384 words); and three increments of 262,144 characters (32,768 words)	<b>Read/Write Channels:</b>	16 basic (eight plus eight auxiliaries)
<b>Simultaneous Access to Memory:</b>	Up to four accesses at one time	<b>Simultaneous Peripheral Operations:</b>	16 basic plus 16 optional for 32 total
<b>Memory Addressing:</b>	Word or character	<b>Other Standard Features:</b>	Parallel processing; multiprocessing; multiprogramming; comprehensive memory protection; input/output protection; program interrupt; program assignable input/output channels
<b>Control Memories:</b>	10 with a total of 352 registers (nine with 32 registers each; one with 64)	<b>Options:</b>	Scientific floating-point instructions with a range of normalized values from $10^{-616}$ to $10^{616}$ ; 16 additional read/write channels (eight plus eight auxiliary)
<b>Internal Operations:</b>	Decimal and binary arithmetic (including multiply/divide), logic operations, peripheral control	<b>Prices:</b>	
<b>Instruction Types:</b>	Fixed-length word; Variable-length character	<b>Lease (per month)</b>	\$21,700 to \$51,000
<b>Internal Checking:</b>	Parity checking; illegal operation codes; Or-thotronic control	<b>Purchase</b>	\$1,041,600 to \$2,448,000
<b>Input/Output Trunks:</b>	48 I/O control units may be connected	<b>Delivery:</b>	Second half of 1967

**UNIVAC 1830 Military Computer**

*UNIVAC Division  
Sperry Rand Corporation  
New York 19, New York*

The first UNIVAC 1830, a new microelectronic military computer, has been delivered to the Naval Air Development Center (NADC) Johnsville, Pennsylvania, by the Sperry Rand Corporation's UNIVAC Defense Systems Division.

Also labeled the CP-823/U (a Department of Defense designator), the computer was developed under a contract with NADC and the U. S. Navy Bureau of Weapons. It will serve as the nucleus of the Navy's A-NEW Program, an improved airborne Anti-Submarine Warfare Tactical Command and Control System. Once integrated with other components of the system in an airborne environment, the miniaturized computer will be required to perform a multi-

plicity of functions, a decided improvement in accuracy and efficiency over present manual methods.

The 1830 is a militarized general purpose digital computer intended for manned tactical data systems operating in extreme environments where small size and high performance are critical requirements. Constructed of silicon microelectronic circuits, it features a choice of either magnetic thin-film or core memory.

Because the 1830 is fully compatible with other UNIVAC military computers, existing operationally proven programs can be used without modification. Input/Output compatibility is

also incorporated in the 1830, allowing use of the complete line of UNIVAC military peripheral equipments.

In addition to Anti-Submarine Warfare use, the UNIVAC 1830 is expected to find wide application in such areas as airborne command and control, fire control, battlefield command and control, missile command, control and launch, radar data processing, and shipboard systems.

The 1830 delivered to NADC has both a magnetic thin-film and a ferrite core memory, which in combination provide a total storage capacity of 32,768 words of 30-bit length. The memory cycle time is four microseconds. Modular design allows a range of total memory size

from 4096 words through 32,768 words in 4096 word increments.

Input/Output is provided through four input and four output channels available at the central processor. Each channel may be connected to a 4-channel multiplexer, allowing a total channel capacity of 16 input and 16 output channels which run asynchronously with the program under buffer control. Data can be transferred at the rate of 3,750,000 bits per second in 30-bit parallel words.

Modularity and maintainability have been emphasized by packaging the central processor, the memory, the I/O, and the power supply as individual units; this also allows flexibility in selecting a memory size and the number of I/O channels to closely match job requirements.

## Computing Centers

### Management Information System

*Continental Airlines  
Los Angeles, California 90009*

Continental Airlines has signed a \$5,000,000 contract with IBM for the airline industry's most advanced management information system. Starting in September 1967, Continental will have two IBM System/360, Model 50 computers in operation. The computers, first to combine reservations, communications, and data processing in one system, will provide a broad range of customer services and will be programmed to supply information to management in all areas of the company's operation.

The system will do everything from producing instantaneous reservations and flight information to keeping tabs on passenger waiting lists, providing weather reports and profit and loss data on each flight, and handling all telecommunications. The system also will have the inherent capability of being programmed in the future for such advanced passenger services as computing fares and even writing tickets.

To produce passenger information for management, the computer will scan its large memory in microseconds, then flash the correct answer onto a cathode ray tube of an IBM 2260 visual display unit. The units will be available at all reservations and ticket counter positions across the company's system. A reservation agent, for example, will use the visual display terminal to determine all Continental flights from Los Angeles to Chicago on a given day, indicating flight number, time of departure, availability of space in each class of service, the types of meal service, and even the name of the movie. If a reservation is made, the agent will enter the information in the memory of the central computer by means of a typewriter-like keyboard.

Besides providing the reservations and flight information service, the computer will light up with itineraries as fast as they're requested, no matter how complicated they are, as well as show the proper fare tables.

The 360 will free present employees from paper shuffling, to let them more directly serve the customer. Continental has more than 200,000 pieces of paper in its file at all times concerning current or future reservations. The 360 will maintain all passenger records, including firm reservations, reservation requests, itinerary changes, and passenger contacts. It will help eliminate "no shows" by keeping track of ticket pickup limits and reporting duplicate bookings by passengers, print departure manifests, list customers who need to be advised of schedule delays or changes.

The System/360 also will be used for schedule preparation, as well as for flight planning, fuel planning, aircraft weight and balance, flight monitoring operations reporting, crew records, and scheduling.

To help maintenance, the computer will handle continuous inventory control, aircraft maintenance forecasting, time control of components, engine overhaul and shop scheduling.

Continental will gain even better control of costs as the computer is programmed for financial forecasting, budget forecasting, expanded data processing in the fields of accounting, personnel records, sales, and operations. The system also will permit finely detailed profit and loss analysis of each flight.

Besides handling its own needs, Continental plans to offer unused capacity to other airlines and corporations.

William C. Powell, Continental's manager of data processing, will head the company's programming and application team. Aiding him will be Preston P. Hopkins, director of telecommunications and Harold L. Purdom, director of reservations.

## ALCOR ILLINOIS 7040/7090 Compilers

Department of Computer Science  
University of Illinois  
Urbana, Illinois 61803

In the 4-month-period ending April 1, 1965, the ALGOL Compiler ALCOR ILLINOIS 7090 was rewritten for the IBM 7040/44 computers by the Rechenzentrum, Munich Institute of Technology, with the assistance of IBM-Deutschland and the Darmstadt Institute of Technology.

An ALGOL compiler, translating ALGOL as defined by the ALGOL 60 REVISED REPORT (including recursive procedures) with the exception of own is therefore now available for the IBM 709, 7040, 7044, 7090, and 7094 computers. The project was originally started in June 1962 by the University of Illinois and the Mainz and Munich Institutes of Technology.

The four pass compilers generate machine programs which use, wherever possible, linear incrementing of addresses for subscripted variables within for statements in order to optimize execution time. Execution time is, in favorable cases, about the same as for a corresponding FORTRAN program. Most programs of linear algebra are 1.1 to 1.5 times slower in ALGOL than in FORTRAN, while programs using mainly integer arithmetic may be two times slower.

The compiler is, on the other hand, extremely fast in translating. Small programs of 5 to 15 cards are translated in less than 10 (15) seconds on the IBM 7090 (7040), while a large program of 600 cards is compiled in less than 30 (90) seconds.

All compilers are available in a parameterized form, making it possible to imbed them in any existing system without unreasonable efforts. The ALCOR ILLINOIS 7090 is also directly available in PORTHOS (University of Illinois monitor system) while the ALCOR ILLINOIS 7040 is directly available as a job on a magnetic tape which, when run, will automatically imbed the compiler in the IBSYS monitor system.

Details of the ALCOR ILLINOIS 7090 may be obtained by writing to: Digital Computer Laboratory, University of Illinois, Urbana, Illinois 61803.

For information about the ALCOR ILLINOIS 7040 write to: Research and Instructional Development, Data Processing and Computing Center, Southern Illinois University, Carbondale, Illinois.

## Data Reduction for Explorer XXV

The University of Iowa  
Iowa City, Iowa 52240

Data reduction with Explorer XXV is being handled on a real-time basis at the University of Iowa, the primary receiving station for data from the satellite. (Explorer XXV is also known as Injun Explorer, the fourth in the series of University-produced satellites used in the high-altitude cosmic ray studies directed by Dr. James A. Van Allen of the University of Iowa.)

Launched Nov. 21, 1964 as the Air Density/Injun Explorer, the Iowa satellite is in a polar orbit with a perigee of 524 kilometers and an apogee of 2494 kilometers. The Langley Research Center's air density experiment, called Explorer XXIV, is in a similar orbit, having been expelled from a canister within the Injun Explorer shortly after the satellite was in orbit.

The Office of Naval Research, which has supported cosmic ray studies by Dr. Van Allen

and his associates at Iowa since 1952, is supporting the University's tracking system and the data reduction. In addition to data taken at the tracking station 12 miles south of Iowa City campus, data tapes are received from NASA's Satellite Tracking and Data Acquisition Network also.

A UNIVAC 418 computer is the heart of the data reduction program. Housed in the Physics Building at The University of Iowa, the equipment includes the computer, printer, car processor, and four tape units.

The tracking station has a 28-foot parabolic dish antenna with cross dipole. This rig is mounted on a converted shipboard gunmount provided by the Office of Naval Research.

Five or six passes of the satellite come within range of the Iowa City station every 24

hours. Each period of data reception lasts from 10 to 20 minutes. Data are transmitted from the satellite by two transmitters at two rates—144 bits per second (a telemetry transmitter) when experiments are sampled directly, and 5760 bits per second when data come out of the on-board recorder. This recorder stores 5-1/2 hours of data. On command, the recorder will play back in just 8 minutes.

The signal from the dish antenna goes into two, phase-locking, crystal-controlled receivers whose output is fed into a diversity combiner. The combined output is recorded at the tracking station and simultaneously transmitted by micro-wave link to the Physics Building. The signal is then made ready for introduction into the computer, to obtain a printout, and for simultaneous storage on tape. A Cal-Comp plotter is used with the UNIVAC 1004-III to put data into graph form.

The real-time capability has been used mainly to control the satellite operation system as was done when a power problem arose because the satellite was in eclipse by the earth during apogee. Without sufficient sunlight, solar cells did not meet the battery power required for all

the experiments. The problem became evident quite soon, however, and some experiments, the high-power transmitter and the tape recorder were switched off until the situation corrected itself. Injun Explorer has an expected life of about 1 year.

Like its predecessors, Injun Explorer is designed as an integrated research payload custom-tailored to achieve the specific aims of the flight. Inside the satellite and protruding from its surface are 16 separate sensors for measuring radiation of different kinds and intensities. The 90-pound satellite is roughly spherical in shape and 24 inches in diameter. It has 40 flat surfaces, 30 of them studded with solar cells.

A UNIVAC 418 and allied equipment was placed in a custom-built mobile electronics van for use in the build-up, pre-launch, and launch checkouts, and was then used at Iowa City for data reduction until a second 418 computer was installed in the Physics Building. The 40-foot van will be used again for the launch of the next Injun satellite, which is tentatively set for next year.

#### Analog Simulation on the 7040

*Computing Center  
University of Kentucky  
Lexington, Kentucky 40506*

Because of the shortcomings of the analog computer, many programs have been written to simulate the analog computer on a digital computer. But almost all of these programs fall greatly in man-machine communication. In using an analog computer, it is normally desirable to run a program several times with different voltages of potentiometer settings. R. D. Brennen and H. Sano have written a Digital Analog simulation program for the IBM 1620 digital computer, called PACTOLUS, which achieved good man-machine communication through the use of program switches and a console typewriter. The program permits the user to enter changes through the console typewriter before each rerun.

In trying to modify the PACTOLUS program for the 7040 it was found that because of speed

and the cost of the 7040, the method of communication used by Brennen and Sano was impractical. Therefore, it was necessary to develop a new method of communication. It was found that the required flexibility could be obtained through the use of control cards which permit the user to change voltages or potentiometer settings and even make minor changes in his program before each rerun. The user can make as many runs with the same basic setup as he wishes. The 7040 PACTOLUS system is flexible enough for most analog computer users, and its operations simple enough to be learned in half an hour.

The computing center now has the PACTOLUS simulator for both the IBM 1620 and the 7040.

#### NARDIS

*Office of Naval Research  
Washington, D.C. 20360*

In January 1964, work was begun on a new computer-oriented Navy Automated Research

and Development Information System (NARDIS). The work was initiated by the Chief of Naval Re-

search (CNR), at the direction of the Assistant Secretary of the Navy for Research and Development.

The basic objectives of NARDIS are to establish a common data bank which will serve as a prime source of scientific, technical, and administrative information for all Navy-sponsored research and development; to meet DoD requirements for reporting all levels (project, subproject, or task area, and work units) of Navy-sponsored research to the Defense Documentation Center (DDC) in digital form for computer processing; and to promote intercommunication among the scientific, engineering, and technical personnel in the Navy.

The NARDIS establishment is under the general technical and policy control of the Research Coordinator, Office of Naval Research (Code 104), and under the general administrative control of the Bureau of Ships (David Taylor Model Basin).

The core of NARDIS will be the UNIVAC LARC computer, which will be utilized in all file development and maintenance; in management and subject matter searches; in data transmissions to DDC; and in checking (nonintellectual) the consistency of most of the NARDIS manual operations. There is one area, at present, where the computer will not play the dominant role, and that is in subject matter indexing, which is a task assigned to physical scientists and technical librarians. The computer will be backed up by volume keypunching, tape printing, card-to-tape and tape-to-card conversion capabilities, and microfilm equipment that can reproduce "duplicate aperture cards" as well as "hard copies" in large volumes.

All research and development reports required by DDR&E will be digitalized on magnetic tape, checked for consistency, and transmitted to DDC. This is to be accomplished upon receipt of new or up-dated research and development information.

A microfilm research and development file will be established to back-up the computer research and development file, to serve as complete or partial source for authorized Navy components, and to serve as a source for textual research and development replies to technical queries.

The "objective," "approach," and "progress" of all research and development work units will be indexed by subject to make these categories of information amenable to subject matter searching.

As NARDIS becomes completely operational, the staff is becoming concerned with the development and maintenance of four major magnetic tape files (LOG, TEXT, SUB, and THES) and one microfilm file (MICRO).

● "LOG," the R&D Administrative Data File, will contain all of the data elements on Forms DD 1498 and the NARDIS Supplement to 1498, except the textual items. LOG is expected to be a "heavy traffic" file because it must be searched to answer most, if not all, management and administrative data type questions posed to NARDIS.

● "TEXT," the R&D Textual File, will contain, as the title implies, the textual items for DD Form 1498 and its NARDIS Supplement. TEXT is expected to be a large (about 20 LARC reels) but "low traffic" file. It includes the digitalized text required by DoD.

● "SUB," the R&D Subject Matter File, will contain the descriptor codes, links, and roles which will result from the subject matter indexing of the "objective," "approach," and "progress" statements of each research and exploratory development assigned in the Navy.

● "THES," the R&D Thesaurus File, will contain the technical terms, their codes, their synonyms, and their "hierarchically" related terms. THES will also contain special definitions and remarks as "scoop notes."

● MICRO," the NARDIS Microfilm File, will consist of aperture cards as images of DD Form 1498 and its NARDIS Supplement for all Navy-sponsored research and development.

From an operational viewpoint, the NARDIS establishment will be equally responsive to administrative queries from all Navy management levels and to technical questions from individual Navy scientists. The clearinghouse for all queries to and responses from NARDIS is the ONR Research Coordinator (Code 104). Information transmitted to the system's data bank will be in a form mutually agreed upon by the cognizant bureau and the NARDIS establishment.

In order to relieve the responsible investigator from many burdensome and clerical tasks, the NARDIS staff will assume as much of the responsibility as possible for reporting information to and from the data bank. In no way, however, will the user of NARDIS storage and retrieval services be required to be familiar with the details of the computer system and programs.

**Control Data 6600**  
*Courant Institute of Mathematical Sciences  
New York University  
New York, New York*

A Control Data 6600, one of the fastest and most powerful computers in the world today, has been installed at New York University's Courant Institute of Mathematical Sciences. Installation of Courant's 6600, the first on the east coast, was made at the Institute's recently dedicated Warren Weaver Hall, located at the University's Washington Square Center.

The Institute will use the 6600 to develop methods for using very high-speed computers for applied mathematics and mathematical physics through numerical and non-numerical techniques. It is expected that the speed and computing power of the 6600 will enable scientists and mathematicians at Courant to broaden their work and solve unusually large and complex problems which up to now have defied solution.

The Institute, which combines both applied and pure research, consists of a senior gradu-

ate faculty of 35. It has a staff of 125 scientists (Ph.D's) and an equal number of research assistants and fellows. It enrolls 600 graduate students (mathematics), 200 of them full time.

The mission of the Courant Institute is education combined with basic research. A guiding principle has been to consider mathematics as an organic part of the body of science and to encourage interactions with science and technology. The range of research interests among the members of the Institute is broad, extending from purely mathematical questions in group theory and functional analysis to applied mathematical problems involved in attempts to diminish the height of flood-wave crests on the Ohio River and in efforts to control thermonuclear fusion reactions for the peaceful use of atomic energy. Especially in the fields of applied mathematics, the program of the Courant Institute is unique.

**Hybrid Computer System**  
*University of Southern California  
Los Angeles, California*

At the University of Southern California, two computers were linked together to form the "Hybrid Computer System." The best features of each machine were blended together in the interest of efficiency and speed. This hybrid, the result of linking a digital computer (an IBM 1710 Control System) to an analog computer (a Beckman 2132), can simulate the trajectory of missiles, duplicate the behavior of the human circulatory system, or imitate, with great accuracy, the flow of products through a chemical processing plant. By virtue of its ability to store large quantities of data and follow a predetermined, step-by-step program, the IBM 1710 Control System is the overseer of the analog machine. It sets up the problems, feeds the required data into the analog computer and then prints out the answers in readable form.

The analog computer cannot read, write, or remember. But it does excel in rapidly sensing actual physical changes. In simulating a problem, it reports its findings not in letters and numbers, but in wavy lines on graph paper or the movements of a needle on a meter.

Briefly the digital computer counts while the analog computer measures. The abacus is a simple digital computer while the slide rule is a simple analog computer. The hybrid computer derives its power from a combination of these two types of operation.

Located in USC's Olin Hall of Engineering, the System Simulation Laboratory is operated on an open-shop basis. Students and faculty have easy access to its facilities.

Dr. Robert B. McGhee, assistant professor of electrical engineering and co-director of the Laboratory, said that in the last 6 months more than 2000 problems have been solved by more than 250 students. Of special advantage to researchers is the fact that the two computers can be used separately or in unison, depending on the type of problem. The idea is to optimize the treatment of each problem by using the right computer for the most satisfactory solution from both a scientific and an economic standpoint.



**Computer Laboratory**  
*Tulane University*  
*New Orleans, Louisiana 70118*

During May, the largest non-government computer system in Louisiana was put into operation at the Tulane University Computer Laboratory on the main university campus.

The IBM 7044 is part of an expanding computer complex—known as the Tulane Computer Center—which also includes computers at the University's Biomedical Computing System in downtown New Orleans, and its Delta Regional Primate Research Center in Covington, La.

Dr. James W. Sweeney is the director of the Center which will be used for instruction and research; the center represents Tulane's confidence in the growth of the area.

The reasons for the purchase of the \$1.8-million system were:

1. Need of a computer fast enough to keep up with the increased demands by students requiring a computer in their studies.

2. Need of a powerful research tool for advanced projects which can do these jobs more rapidly. (On one series of complex problems, it took only 20 hours to do a job on the 7044

compared with 300 hours on the computer it replaced.)

3. The new system will enable Tulane to attract far more research grants, top-flight faculty members, and graduate students.

The Tulane IBM system features a data channel unit. This device operates independently of the processing unit and provides for problem solving by remote control. A smaller computer, such as the one at the Primate Center, can be connected with the 7044 through this unit.

The unit may also be used to feed information from such outside sources as telegraph or telephone lines into the 56-million-character disk storage file while the main computer is processing other jobs.

The new IBM system will have the capability of working on such diverse projects as menu-planning and simulation of chemical operations. The computer greatly strengthens the university's research capacity. It enables faculty members to do research never before attempted and also enables Tulane to offer courses never before offered.

## Computers and Centers, Overseas

### Control Data 6400 Computer

*Aachen Technical University  
Aachen, Germany*

The Technical University of the State of Rhine (Westfalia), located at Aachen, Germany, has ordered a large-scale Control Data 6400 computer system to be delivered to Aachen in early spring of 1966. The high-speed 6400 computer is to be installed on campus in a new data center now under construction by the university's Architectural Department. According to university officials, this will be the most modern computing center in Europe when completed.

Aachen is located in the most western part of West Germany and lies immediately adjacent to Belgium and Holland. Aachen Technical University, one of Germany's oldest and best known seats of technical learning, enrolls a large number of students from the Middle East, Africa, and various Asian countries, in addition to its heavy enrollment of West German students.

During the official contract signing ceremonies at which Regents of Technical University of Aachen participated, the Dean, Professor Volker Aschoff said, "With the assistance of this new, advanced, large-scale Control Data 6400 computer system, our university will be able to utilize the most advanced techniques of scientific computing in fields associated with our principal research endeavors. This new computer is a tool that will greatly accelerate the state of research in which our institution is presently engaged."

Research programs being carried out at Aachen Technical University include solutions of problems relating to nuclear physics, reactor development, traffic control and planning, electrical drive design, heat transfer, and areas of non-numerical mathematics.

### EL WICOMATIC

*Electrologica  
Den Haag, Netherlands*

Electrologica has announced a revolution in the wiring of panels with contact pins (terminals)—A punched tape controlled wiring device EL WICOMATIC (Wiring and Connecting device, semi-autoMATIC).

With the EL WICOMATIC wiring is fool-proof for it is absolutely impossible that the wrong contact pin will be wired; a new connection cannot be made before the preceding one is completed; errors caused by reading mistakes cannot occur any more because no written documentation is used; so no more time is wasted on checking and repairing.

The device is about five times as fast as with the conventional method; on an average only 30 seconds is required to make a connection and the time normally spent on checking and repairs is entirely saved.

All connections can be made in an orderly fashion in one direction, e.g., from right to left, and for the different levels in even layers. It is so simple that not only skilled, but unskilled personnel may be employed for this purpose as well.

#### OPERATION PRINCIPLE

A panel of contact pins to be wired by the EL WICOMATIC (standard equipment) may consist of up to 64 columns of 32 pins each. A battery-fed, "wire-wrap" pistol (manufactured by Gardner Denver, Ill., USA, and modified to our specifications) is used for wiring, although a pointed welding-pistol or a soldering-iron will also do.

Information telling how the wiring is to be made is recorded, with the aid of a computer,

on five-channel, punched tape; written working instructions are no longer used.

The punched tape contains the following data:

- The column in which the pin to be wired is to be found;

- Which pin in the column is to be wired (for this purpose the pins of a column are divided into a number of groups);

- Which wire length is needed for the connection (there are 31 different wire lengths to choose from).

Which column, pin, and wire-length are next, is indicated by means of lights:

- Over each column there is a light which when lit indicates the column in question;

- In the middle of the upperside of the panel to be wired, two vertical rows of six lights each are fixed; the lights of each row are numbered from 1 to 6 from the top downward, so that a total of 36 combinations is possible, of which 32 may be used. The lights on the left indicate the group and those on the right the pin within this group. If for instance lights no. 3 on the left and no. 5 on the right are lit, this means that the fifth pin in the third group must be wired; a diagram printed on the panel facilitates locating the desired pin;

- To indicate the wire-length, a light is attached to the set of 31 tubes; each of which contains a different wire-length.

To connect two pins, the wire indicated must first be connected to one pin and then to the other. When indicating the place for attaching the second end of the wire no wire-length need be given, of course. This place on the punched tape is used for check purposes. The information for establishing a connection is recorded on the punched tape in two groups of four rows of symbols (pentades) each.

The punched tape reader can be started by pressing a button. The four pentades of the first group contain the information for selecting the wire-length and the first pin and those of the second group the information for the second pin. After reading the first group the transportation of the tape stops. It can only be re-started by pressing a button after the "wire-wrap" pistol had made contact with the pin indicated. It is true that the signals given on the basis of the information on the punched tape

and the lights which are on in consequence indicate the correct pin and wire-length but they alone do not guarantee a faultless execution of the operation.

Therefore they are completed by a series of safeguards which do indeed ensure a faultless execution.

#### CHECKS AND SAFEGUARDS

- During the transportation of the tape no new start instructions can be given.

- The information read from the punched tape is checked on parity. If an error is found the tape transport stops immediately, and a pilot lamp goes on. No new start instructions can be given.

- With each connection the transportation of the tape is checked by the tape reader; for this checking the space on the punched tape on which no wire-length indication need be given is used. If an error is detected this is also indicated by a pilot lamp and no new start instructions can be given.

The principal safeguard prevents the wrong pin from being wired. The "wire-wrap" pistol can only be activated by pulling the trigger-switch as soon as the winding bit of the pistol makes contact with the correct pin which is indicated by the several lights, for it is only this pin that is live. This contact between winding bit and pin causes a relay which is built-in serially with the trigger-switch to come up, lights a lamp which is attached to the pistol, and lights a lamp on the indication panel. In order to prevent the winding bit from making contact with a live pin through its outside so that a faulty connection round a dead pin could be established, the outside is insulated. A new start instruction cannot be given before the pistol has made contact with the correct pin. Finally a small counter indicates the number of connections made, so that it is possible to check whether the wiring had been executed completely.

#### MACHINE DESCRIPTION AND TECHNICAL INFORMATION

The EL WICOMATIC consists of the following parts:

- A table (142 x 86 x 75 cm) with an elevation of 57 cm to which the panel to be wired can be easily attached. On the elevation are the lights for indicating the pin to be wired; the

counter for checking the completion of the wiring; the light which goes on as soon as the winding bit makes contact with the right pin; a button for giving start instructions; and an easily changeable, tape read station with a mechanically punched tape reader, which always reads two pentades at a time (the speed of the tape transport can be set within determined limits).

- The relay box to the right of the table which is connected to the elevation by means of a pluggable connection (practically all relays are closed dead, which ensures a long working life).

- A rack of 31 tubes containing the various wire lengths; for identification a light is attached to each tube. The rack can be changed in a simple manner.

- A "wire-wrap" pistol with a pilot lamp (contact between the pistol and the elevation is made by means of a pluggable connection).

- The EL WICOMATIC is fed direct from the light supply (220 volt 50 cycles). The maximum current consumption is about 2 amp. For the relay connecting 24 volt dc is available. The stepping-up mechanism is fed with 60 volt dc. During the stepping-up the brushes are dead.

#### **Internal Re-Organization** *Elliott-Automation Computers Limited* *London W1, England*

Elliott-Automation has recently completed the internal re-organisation of its computing activities, so that they now more clearly reflect the Group's policy towards the introduction of true automation. Elliott has always believed that the use of computers in the physical control of events, "on-line" working, is of equal significance for the future as the more customary "off-line" use of computers as calculating machines in scientific and business environments.

It is the company's policy to create separate computing capabilities in all those customer-orientated sectors of its activity where there is a potential market for computer controlled systems. This policy has now been implemented throughout a large part of the company, while the "off-line" activities have been concentrated in the Group's Management Company concerned with data processing, the name of which has been changed to Elliott-Automation Computers Limited.

The new company, Elliott-Automation Computers, has two principal activities, the manufacture of computers and their sale for "off-line" applications. These include educational, scientific, and other technological uses of com-

puters, such as building and civil engineering fields in which Elliott computers are widely used both in this country and in over 20 countries overseas. The Company manufactures the Elliott 803, 502, 503, and the new 4100 range of computers both at Borehamwood and at Cowdenbeath in Scotland. It manufactures, as well, the NCR 315 for the National Cash Register Company while that company also sells Elliott Computers for commercial and business data processing applications. More than half of the computers manufactured by the Company are sold overseas, so far to 27 different countries. Among recent export sales have been orders for the Elliott 503 from Czechoslovakia and Holland, for the 803 from Finland and Yugoslavia; and for the newly announced 4100 from Australia and Germany.

The Computing Research Laboratory of Elliott-Automation Computers at Borehamwood is the Group's principal research centre for computing technology. It works in close collaboration with the Company's Microelectronics Group, which has been established in Scotland. The world's first experimental tunnel diode computer which has been developed in the Laboratory is at present on development tests there.

#### **NCR Elliot 4100 Computer** *Scientific Computing Division* *Elliot Brothers, Ltd.* *Borehamwood, Hertfordshire, England*

#### **NEW DATA PROCESSING SYSTEM FOR BUSINESS AND SCIENCE**

The new 4100 data processing system was announced during February. It is currently

being demonstrated at NCR headquarters in Marylebone Road. It represents the fruits of years of experience in data processing by the two companies presenting the machine—NCR and Elliotts. The highly successful 803 has

shown that a small low cost computer capable of performing a wide number of functions had great appeal to a large number of different users. In addition, experience in defence computing, particularly with the Elliott 920 computer, has shown that a highly reliable central processor using all silicon logical elements was a viable possibility.

#### LOW COST MODERN SYSTEM

The 4100 uses the full know how of both Companies to offer at a remarkably low cost a machine useful in a huge range of applications, including those of commerce, control, research, industry, education and government. The system is completely modular and allows a flexibility which is due not only to standard electrical interface units used to link together the many different pieces of equipment available, but also to a modern operating system (EASE) which allows the control and operation of programs to be modified as easily and simply as the connection of a piece of equipment. The system has a highly versatile basic order code which, as well as its obvious benefits to writers of general programs, has enabled the writing of extremely efficient automatic programming systems. These include SAP and NEAT (which are symbolic programming systems orientated respectively to the scientific and the commercial programmer); ALGOL, the international scientific language; Language H for the simple preparation of commercial programs, and Fortran. There are a variety of languages to suit every requirement.

#### READY TO DELIVER

The 4100 has been offered on the market as a ready to deliver machine backed by a large range of supporting services.

As well as the program systems outlined, the 4100 has a large library of ready to use programs and the full weight of the existing Elliott NCR Applications Group behind it.

The education departments of the two Companies offer nearly a dozen different courses of instruction on the 4100 ranging from short Appreciation courses to full length programming sessions covering several languages. Training for operators in the machine procedures are also available.

At all times an efficient maintenance service is available.

There are a number of service centres across the British Isles to ensure that in the

unlikely event of a machine fault, it can be speedily remedied.

The services provided and the machine and its multitude of peripheral and program facilities are available at a low capital cost, the strain of which can be assisted by the generous leasing arrangements which are available. The whole 4100 system makes common sense of computing.

#### THE 4100 HARDWARE

The processor currently available is the 4120 which is a compact, highly reliable unit of modern design intended to be extremely adaptable to a wide range of environmental conditions. A basic system requires only a 13 amp plug and can be installed without any other site preparation.

The processor operates in parallel on binary words of 24 bits in length. A single instruction is generally contained in a word but there are a range of useful instructions of only 12 bits in length which facilitate easy and compact compiler writing. The instruction code includes variants to orders allowing both literal, indirect, B-modified and direct addressing to be employed. The instruction code covers some 400 orders. "Extracode" instructions to cover such important requirements as floating point arithmetic are provided and may be used as normal instructions. A number of important registers are accessible by program to better control the operation of the system.

#### CONTROL

The 4100 uses the most modern of control systems to ease the problems of programmers and operators and for this purpose most installations will require an on-line typewriter through which messages may be passed to the processor and corresponding reports may be output for program control. There is a control box linked directly to the central processor which carries message buttons and sense keys and this is supplied with all processors. The lamps and loud-speaker which this control box also carries enables the state of the computer to be monitored at any given time.

#### STORAGE

The processor may be linked by a standard electrical interface to a number of standard stores which provide up to 32,768 words of immediately addressable storage. The storage

currently available is of 6 microsecond cycle time. Typical operational speeds allow 60,000 operations per second.

#### PERIPHERALS

The modern technique of standard electrical interface has been implemented to allow not only attachment of a full range of equipment but also to expedite additions of new units as they become available. The ability to extend the range and power of a basic processor easily and cheaply is one of the fundamental benefits which standard interface offers. It also means that a future requirement for a faster processor can be implemented without rendering obsolete an existing set of peripherals and software.

There are a large number of peripheral items already available for use on the 4120 processor and these can be summarised under the categories of Basic input/output, auxiliary storage, alphanumeric output, and visual output. The 4120 provides 12 interface sockets to which these units may be connected. Each socket, as well as providing data input and output channels and control data, allows an interrupt to occur at two levels—attention and normal interrupt—and these two levels on each of 12 sockets allows a powerful system of peripheral control.

#### BASIC INPUT/OUTPUT FACILITIES

There are two conventional forms of computer input and output, punched paper tape, and punched cards, and the 4100 system provides both of these. Where paper tape input or output is required there are paper tape punches operating at 100 characters per second and paper tape readers capable of reading 1,000 5-, 6-, 7- or 8-channel characters per second. The requirements of different installations for different functional units has been met by housing these paper tape units in two alternative forms of paper tape station, the 4210 and the 4211. These differ in style and flexibility but otherwise are functionally identical. Card reading is provided for by an economically priced card reader which can handle 400 80-column cards per minute. This elegantly styled unit is robust and resists a very high range of environmental conditions. Similarly, card punching may be added with a 100-card per minute unit.

#### AUXILIARY STORAGE

Although the 4120 can be extended to over 32 thousand words of direct storage there are

both scientific and commercial applications which need further permanent storage facilities to be added. Again, dependent on the application, it is necessary to access the information so stored either serially or at random and there are units which provide separately for these requirements. They can, of course, be combined in any particular system to offer the advantages of both. For the fast access of information stored serially there are magnetic tape storage units offering transfer rates of respectively, 12,000 and 33,000 characters per second. These industry-compatible units are of proven reliability and low priced. They can be attached as a cluster of up to eight in number operating through a single controller and interface channel. This same method of control can be employed with the random access units. These use disc stores which can be changed in 20 seconds and on each side of which can be stored over 600,000 characters of information. The transfer rate is 105,000 characters per second.

#### ALPHA-NUMERIC OUTPUT

Fast output of information is essential in applications where large quantities of data need to be output and there are a number of line printers available for attachment to the 4120. These employ a character set of 56 with the exception of one which has been extended to 62 characters. They normally permit a 120-character line although an option exists on all models for a 160-character line. Printers operate at speeds of 300, 600 and 1,000 lines per minute; the 300 and 600 l.p.m. models are supplied either buffered or unbuffered. Models to supply every need are available and the price range is low enough to ensure that a satisfactory economic answer can be found to all requirements.

#### VISUAL OUTPUT

One of the most recent trends in modern computing has been the development of peripherals to provide the answers to computing problems in a visual and easily assimilated form. The 4100 offers two basic forms of visual output: the plotter where the visuals are inscribed permanently on paper, and the cathode ray tube (C.R.T.) display for much faster but more transient display of information with a facility for visual data to be passed to the computer through the same agency. These methods are valuable in applications ranging from the commercial—such as the rapid display of sales curves—to the scientific and on line with fast display of calculation and feed back data. Digital plotters are

available with a variety of plotting widths and step sizes to suit most requirements and with speeds of up to 300 steps per second. The C.R.T. display consists of a console carrying a 14-inch tube. Curves and lines can be drawn by defining a spot on a grid of 1024 x 1024 squares. A character generator may be added to ease the annotation of displays. A further addition is the light pen which enables material to be drawn on to the face of the C.R.T. and for the information to be passed to the computer as input or amendment data.

### SUPPORTING SERVICES

The 4100 already offers a range of equipment which will cover most scientific and commercial applications. The Elliott policy is one of continual improvement and the 4100 is particularly designed to enable the range to be modified and increased as technology allows.

The 4100 has been the product of years of experience and research and the hardware described here and the software detailed overleaf are results of this activity. This alone, however, has not been the sole fruit of the years of activity in computing for there has been developed a wide range of services designed to assist the user of computer equipment at every stage of his work. The potential purchaser of a 4100 will receive the specialist information on site preparation, installation, and maintenance which has been aggregated in the Computer Maintenance Division of Elliott-Automation. This division deals solely in this work and has a number of centres throughout the country from which it operates. Where a computer purchaser wishes to make his own maintenance arrangements—usually overseas—there is a well equipped engineering school where his engineers can train. There are educational courses of various levels covering all aspects of programming and operating the 4100 and these are run by a highly skilled staff of lecturers. With each system a complete manual is delivered describing the system and including a wide variety of library programs; this is updated regularly at no further cost. At the time of installation and at regular periods thereafter the after-sales service section will visit U.K. installations to advise and assist in all problems which might arise. The Users Group organisation also exists to disseminate both application programs and installation experience and there are regular meetings to exchange information. All these services, with the exception of maintenance, are provided free of charge to assist the potential and actual user at all times and in every way to use his equipment to the full.

### 4100 SYSTEMS SOFTWARE

To complement the modular "hardware" of the 4100 system a range of modular "software" has been designed to simplify the writing of efficient programs that will make the best possible use of any configuration of equipment.

The overall software system, known as EASE, consists of a set of three programs: NICE, SPAN, and TSS that together provide the means of communicating with the computer; setting up and operating programs; allocating storage to programs and data; and organising the use of peripherals.

#### NICE—NORMAL INPUT AND CONTROL EXECUTIVE

Together with the message button situated on the control box of the 4100, NICE provides the means for man/machine communication. When the message button is pressed, control is transferred to the EXECUTIVE routine in NICE. The operator will normally type the name of one of the programs already in the computer store. NICE will locate the program and transfer control to it. Alternatively the operator may type a message asking for input of a program. The NICE input routine will then read in the program, and place it in some available free storage.

Optional routines are provided with NICE for listing on the typewriter, the names of all programs in the computer removing programs from the store, and continuing with a program which has been interrupted.

#### SPAN—STORAGE PLANNING AND ALLOCATION

The main store of the 4100 is extendable to 32,768 words, which is ample for many applications. Where very large programs and data arrays are involved, however, backing store, such as magnetic discs, may be added to the system. SPAN arranges the layout and administers all the storage, main or auxiliary, of the 4100. All transfers between different levels of storage are handled automatically by SPAN with the minimum of assistance from the programmer.

SPAN divides the main and auxiliary store into a set of blocks each of which may hold program, workspace, or data. Programs written in automatic languages, such as Algol or Language H, are divided into chapters according to the structure of the source program; for example, each Algol block will be considered as a

separate chapter. When a programmer writes in Symbolic Assembly code he has complete control over the division of his own program into chapters.

During a program run-time SPAN ensures that all chapters currently in use are in the main store. If more space is needed SPAN will move unused chapters out to backing store until enough space has been made available. The programmer may help make this process more efficient by specifying which chapters he is not using and asking for the recall of a chapter from backing store before it is needed, thus allowing the transfer to be timeshared with computation.

Such a storage planning scheme has the advantage of treating the main store of the computer and the auxiliary store, as one very large single level store. Program size and the quantity of data are no longer limited by the main core store size.

#### TSS-TIME SHARING SUPERVISOR

For normal input and output requirements comprehensive input and output routines are provided which use TSS to time share all peripheral transfers.

Where more direct control of input and output is required TSS may be used directly by the programmer. Time sharing of peripheral transfers in the optimum fashion is done for the programmer by the TSS.

There are 12 standard interface channels with the basic 4120 processor, each of which may be connected to a single device, or to a controller attached to a cluster of devices. Each interface channel has an interrupt line and an attention line to the central processor, the interrupt line having the higher priority. An interrupt is normally received when the device is ready to handle a transfer, and an attention when the state of the device requires the operator's services.

When a program wishes to input or output data it first obtains a block from SPAN to be used as a buffer area. For output this buffer will be filled with characters then handed to TSS with a request for output on a certain device. If the device is free, output starts immediately and continues on an interrupt basis simultaneously with the main program. If, however, the device was already busy on some previous job the buffer is attached to a queue of jobs waiting for the device. Control is returned to the main program and the buffer is output in due course. Input is similar, but here an empty

buffer is given to TSS for attachment to a queue. When it has been filled it is returned to the main program for use.

Using the queuing and interrupt routines provided in TSS the input and output is smoothed throughout a program, such that the central processor is not held up waiting for a peripheral to become free. A high efficiency in the use of peripherals can be achieved without the necessity for special programming techniques.

#### 4100 ASSEMBLERS AND COMPILERS

A variety of assemblers and compilers for both scientific and commercial use are being implemented on the 4100 Data Processing system.

SAP, the Symbolic Assembly Program, is designed so that the programmer can use easily remembered mnemonics for function codes and symbolic addresses when writing a program. SAP translates the program into the basic machine code, either directly into the computer store for load and go operation, or out on to paper tape to provide a copy for repeated use.

An advanced assembler NEAT is also provided which offers several additional facilities, such as a printed listing of the source program, together with comments and references to facilitate debugging, and details of all syntactical errors found in the source program. Programs produced by both these assemblers are intended for use with the EASE systems software.

Source programs for the advanced assembler may be held on paper tape, cards, or magnetic tape and the translated program can be put on any of these media. Amendments can be made to a previously translated program held on magnetic tape.

A useful feature of the advanced assembler is the ability to extract subroutines from the magnetic tape subroutine library and to insert them in the object program at points specified by the programmer. The library of subroutines covers such activities as peripheral control, file handling, and internal data handling.

Ample debugging, sorting, and report-writing facilities are provided with both assemblers.

#### COMPILERS

The Scientific user is provided with both Algol and Fortran compilers, thus giving him



access to the large library of routines of general use published in various journals, in addition to the many programs provided by the manufacturers.

The Algol compiler implements both the ECMA and 803/503 subsets of the language, allowing a wide range of existing programs to be run without modification. Programs written in Algol can make full use of all peripherals, such as line printers and magnetic disc stores.

The Fortran IV compiler makes available to the 4100 user the many programs written in

Fortran throughout the world, especially in the United States.

Language H is a new commercial programming language, mainly composed of English words, which simplifies and speeds up program writing for the 4100. The vocabulary and set of rules have been kept as small as possible such that it can be learned and used more easily than other machine independent languages.

The range of compilers and languages supplies the need of every kind of user and the expert may additionally avail himself of the highly developed machine code to device further specialist languages.

### DOCEO, Adaptive Teaching System

*Centre De Calcul Et De  
Traitement De L'Information  
Université De Liège  
Liège, France*

#### DOCEO

An adaptive automatic teaching system has been designed and constructed at the Department of Applied Mathematics and Data Processing, University of Liège. Its aim is to establish with a pupil a dialog which simulates, as closely as possible, the dialog between teacher and pupil.

At the present stage, it comprises a data-processing machine, connected to an experimental teaching console, by means of which the dialog between a student and the computer is established.

The computer communicates with the student by controlling the display of two kinds of data, which are stored in the console itself: the lessons material, on 16-mm frames, and a set of light windows on which can appear predetermined comments about the behavior of the student.

The student answers the computer by dialing numbers on a telephone dial.

From a didactic point of view, the main characteristics of the system are as follows:

1. There are two types of didactic statements: "orders" and the "didactic program." Orders are instructions expressing didactic procedures that are common to all lessons or to a set of lessons that require the same achievement criteria. The didactic program contains the instructions that are peculiar to one lesson.

2. By combined use of orders and program, the following functions are performed:

- Permanent control of the learning process.
- Recording of the pupil's work, and adding up, by a set of counters, the different scores of the student's behavior.
- Learning path conditioning, according to various criteria: last answer delivered, but previous answers too; scores recorded; psychological constants which arise from the pupil's reactions (absent-mindedness, memory, ability for abstraction); reaction time of the pupil.
- Print-out and card-punching of an account, showing learning path, learning, and scores.

From the programmer's point of view, it is necessary to point out the fact that the teacher makes use of a didactic programming language, freeing him from most of the programming burden. For this purpose, the system is provided with a monitor program performing two functions: system monitoring and interpretation of didactic statements.

The computer used until now is a BULL Gamma ET with magnetic drum storage.

Future plans include the introduction of several teaching stations working simultaneously for use in an experimental class. The philosophy of the system will be left unchanged. In addition, the use of sound equipment at the console is under investigation.

**Computer Laboratory**  
*Department of Applied Mathematics*  
*The University of Liverpool*  
*Liverpool 3, England*

The University of Liverpool is at present expanding its English Electric KDF9 computer by doubling the size of the core store to 32,000 words, adding two magnetic tape decks, and a card reader.

A. Young, formerly director of the Laboratory, has been appointed to the Chair of Nu-

merical Analysis, and a new director is to be selected.

The Medical Research Council has made a grant to the Laboratory to employ a research assistant to pursue research on the function of the liver and to investigate computer models of extraction processes in the liver.

**Computing Laboratory**  
*Oxford University*  
*Oxford, England*

**EQUIPMENT**

£100,000 of new equipment has been ordered for the English Electric-Leo KDF9 machine installed in the Laboratory. The new installation will have 32K core store, 6 magnetic tape units, time-sharing hardware, two paper-tape readers, two paper-tape punches, and a 600-line-per-minute on-line printer.

**RESEARCH**

A new unit, headed by Dr. C. Strachey, will start research early in 1966 on "non-numerical" computer topics, including the mathematical theory of programming languages, heuristic programming, and other software developments. The unit will advise and assist the growing number of machine users for research in the non-scientific departments of the University.

**POST-GRADUATE DIPLOMA**

The Mathematics Faculty has instituted a 1-year Diploma in Advanced Mathematics. The course consists in the study of three mathematical topics, two at the level of the advanced (optional) papers in the Final undergraduate examination, and one at a still higher level at the frontiers of research. Candidates will be examined orally, and will submit a critical dissertation of recent published work in their main field. Successful Diplomats can then proceed to research for the degree of Doctor of Philosophy. Present Diploma topics include Algebra, Analysis, Topology, Logic, Geometry, Quantum Theory, Fluid Dynamics, Relativity, Statistical Mechanics, Probability and Numerical Analysis. Others, including possibly some non-numerical computer field, will be added from time to time with the approval of the Mathematics Faculty Board.

## Miscellaneous

**Automation Plans**  
*American Stock Exchange*  
*New York, New York 10006*

The American Stock Exchange announced in April a five-point automation program centered around unique electronic keyboards at each trading post for transaction reporting direct to stock tickers. The program also envisions input of data for computer operation of stock clearing and market surveillance.

The plan includes:

- On-floor input, by early 1966, of market data through electronic keyboards supplied by The Bunker-Ramo Corporation. Data will be transmitted on stock tickers within seconds compared with the present interval of about 3 minutes.

- Subsequent switch-over to computer operation of stock and quotation tickers to provide fuller capability for error detection.

- Introduction of advanced computer-processing of Clearing Corporation data to provide added capacity, cut costs, and reduce time-gaps, where possible, through direct input from the trading floor.

- Automated surveillance programs to help assess the depth, continuity, and orderliness of markets against guideposts developed by the Exchange during the past 2 years.

- Automated stock-watch techniques to spot unusual market patterns for prompt study.

The goal is a "balanced, up-to-date blend of automation techniques to help serve and protect the public. On-floor input of trading data is the essential first step in harnessing technology to meet this goal. An equally important step is consultation with member organizations and other exchanges to help assure compatibility of Exchange automation programs where possible with others in the securities industry. The Exchange set two prime objectives: first, to develop a complete plan and, second, to obtain an economical, flexible data input device to operate as and where trading occurs.

The Exchange and The Bunker-Ramo Corporation announced an agreement whereby the Exchange will rent two special-purpose data processors and 40 electronic keyboards from Bunker-Ramo to set up the on-floor input system.

The portable keyboards, to be mounted at trading posts, feature cathode ray tubes for on-the-spot checking of information by input operators. The devices will feed data to the processors for nationwide transmission throughout the ticker network within seconds.

Electronic displays of market data on easy-to-read screens permit fast, visual verification and error detection before transmission of sales and quotations. The development of inexpensive cathode ray tube displays was a key factor in making the new system feasible and economical for the American Stock Exchange.

The first keyboard units will be delivered within 6 months. After extensive testing, final installation is expected early next year.

The Exchange's program follows a year-long study by an eight-man Committee on Automation drawn from the Exchange's Board of Governors and the general membership, backed by electronics engineers in the Exchange's Data Systems Division.

The first American Exchange computer operation, an automated telephone quotation service called "Am-Quote," went into full service in May 1964. "Am-Quote," a computer with a voice which supplies a wide range of market information, also was designed and built for the Exchange by The Bunker-Ramo Corporation and is operated at the latter's TeleCenter in downtown New York.

### ON-FLOOR INPUT

Direct floor-to-ticker input of market data will have no disruptive effect on market operations or procedures. Exchange clerks will operate the relatively uncomplicated keyboards

from the center of each of the 23 trading posts. The electronic keyboards and processors will be rented by the Exchange from Bunker-Ramo at a cost of approximately \$8,800 a month. The system will work as follows:

CMF (a fictional ticker symbol) trades 100 shares at 25-3/4. The trading post entry clerk simply depresses six keys on the electronic keyboard to activate the data processor—three keys for the ticker symbol, two for the whole number and one for the fraction.

The processor flashes a display of the data "CMF 25-3/4" on the keyboard's cathode ray tube, and the clerk visually checks the entry for accuracy. He then depresses an "enter key." The processor routes the signal to Western Union ticker circuits for automatic transmission throughout the Exchange's nationwide stock ticker network.

In a matter of seconds, the trade has been effected, entered in the processor, checked for error, and transmitted on the ticker tape. The present system takes approximately 3 minutes. Similar procedures will be followed in flashing bid-asked changes to the stock quotation network.

The speed and accuracy of on-floor input will enable investors to learn of sale and quotation changes almost simultaneously with the market activity which brought them about. Eventually, transmissions on the sales and quotation tickers will be monitored by computers, thus building error detection and validity checking into the system prior to ticker transmission.

The system for validity checking is to be similar to one presently used in the "Am-Quote" talking computer. For example, an issue is quoted 25-1/2 bid, offered at 25-3/4, and an entry clerk who means to transmit a 25-1/2 sale figure inadvertently "keys" it into the system as 52-1/2.

The computer would be programmed to reject the incorrect report, prevent its transmission over the ticker tape and print out information for corrective action.

Also planned is an optical scanner that would operate in conjunction with the electronic keyboards.

With the scanner, the trading post entry clerk will place a transaction report into a "scan-slot" while he "keys" the trade through the computer to the sales ticker. Details printed on the back of the report, such as code

numbers identifying the trade and the originating broker, will be read by the scanner as the trade information is keyed into the system. This data will bypass the transmitter into temporary memory storage. It will be held there for use by the Exchange in the newly automated ancillary services—clearing, market surveillance, and stock watch.

Trade details read by the optical scanner and stored in memory will enable the Exchange to help reduce the heavy back-office workload, member organizations now experience in preparing clearing reports.

So-called "Deliver Exchange" tickets also would be eliminated. This is a time-consuming documentation of member organization's buying and selling activity listing trades, securities, volume, price and opposite broker.

#### SURVEILLANCE AND STOCK WATCH

The massive amount of detail flowing from on-floor input will be utilized by a computer to give depth, scope, speed and greater accuracy to the Exchange's surveillance and stock watch programs.

Since 1963, the American Exchange has made major advances in its surveillance and stock watch operations. The program is divided into two phases, early review of specialist and registered trader activity, and prompt scrutiny of unusual price and volume movements.

Whenever a security reflects price or volume variations from established patterns, the issue comes under close study by the Exchange. With automated equipment, the mass of data generated in an active market session can be stored, compiled and recaptured by computer to provide statistical detail to gauge quality performance in terms of established standards. This data, including certain details not actually transmitted on stock tickers, will widen the scope of Exchange surveillance and could make possible, for example, the quick recapitulation of key trades that occurred at any time in a trading session.

#### CLEARING CORPORATION

Automation of the Clearing Corporation is a "priority matter" in the overall program. Information available through a computer will make possible an advanced clearance operation based on direct trade comparisons by data processor.

Data made available through the on-floor input system and stored on memory drums will be the prime source of information for automated stock clearing. Initial capacity of the automated clearance operation is to be at least 5 million shares per day plus 5000 trades daily in over-the-counter issues for the National OTC Clearing Corporation. This capability can be expanded readily to handle 10 million shares daily plus 10,000 trades for the NOTC.

At present the Exchange's Clearing Corporation is geared to handle sustained volume averaging 2.5 million shares a day, plus 2000 trades cleared daily in over-the-counter issues, but can handle heavier loads over limited periods of time. An automated clearing operation will have the flexibility and the additional capacity to cope with unusually heavy volume over a sustained period, as well as providing other statistical runs and services.

#### TECHNICAL DESCRIPTION

The system consists of a number of keyboard-type input devices with integral mounted cathode ray tube display, dual control units which include logic for multiple message buffering, display and transmission formatting, character generation and line bidding, and a dual transmission capability for merging and transmitting the output from the control units into the sale and quotation transmission lines. All circuitry is of modular transistor logic board construction.

Initially, the system will have a capacity for simultaneously accepting input data from 66 input devices with capability for expansion up to 99 devices. In its initial function, the On-Floor Input System will be used to transmit market data directly to the Exchange's sale and quotation tickers at the current speed of 500 characters per minute. Soon afterwards, the Input System will be interfaced with a general purpose data processor from which the ticker output will be derived. The initial system design includes provision for dual high speed output for implementing this step.

The input device is a light-weight unit with a specially designed keyboard aimed at providing a simple and rapid means for entering sale and quotation data. The device includes a 5-inch cathode ray tube that will display each entry in a format identical to the source document used by the input operator, and will permit pre-entry message validation. The operator can adjust the size and intensity of displayed characters. The device includes a facility for selective data correction and voiding of a complete entry. A security symbol repeat key is included for use during periods of heavy activity in a given stock issue.

Each input device is cable-connected to one of two remotely located control units which contain magnetostrictive delay line buffering for 192 characters from each input device. In addition, the control units format and drive the video display for each input device and generate bids to the transmission logic for access to the appropriate line as defined by the input entry.

The transmitter section has the capacity to service bids in sequence from three control units for simultaneous transmission on both output lines and from up to four 8-level ticker code keyboard perforators operating in conjunction with 500 operations per minute paper tape readers. The latter will be used for entry of Exchange announcements and correction messages.

When the system is interfaced to a general purpose computer, a group of 10 input device function keys will be activated that will permit the identification of special types of transactions, odd lot transactions, as well as specialist participation in trading. A further addition will be the addition of optical scanners that will read pre-printed bar coded data on the back of transaction reports and permit the capture of broker identification data at the time of entry of sale data. This information will be transmitted at high speed to the central processor that will store the sale and identification data for further clearing and surveillance processing and transmit the sale and quotation data to the ticker networks. The capability for expansion to include these functions is provided for in the design of the initial floor input system.

#### Long Distance Error Control

*Bell Telephone Laboratories  
463 West Street  
New York 14, New York*

A new error detection-retransmission system has made it possible to send a stream of nearly a billion bits of data without errors over

the long distance, dial telephone network. This high accuracy on switched telephone connections, which vary in transmission quality, was

achieved with a system designed and built at Bell Telephone Laboratories.

The experimental system, which controls errors on the dial telephone network, will go into trial service this summer. Designed by Herbert O. Burton, Lorin P. McRae, Robert N. Watts, and William J. Wolf, the system stores information, retransmits it when errors are detected and, at the same time, maintains an uninterrupted flow of data between the transmitting and receiving business machines.

Data sent by the transmitting business machine at 1200 bits per second arrive at the input buffer of the error control system. There, they are assembled into 48-bit blocks and sent to the

encoder, which adds 12 check bits per block before transmission. The buffer stores several blocks for possible retransmission and has additional capacity for absorbing new input data during periods of retransmission. An identical output buffer at the other end of the system supplies the receiving business machine with data at 1200 bits per second, even during retransmission.

When the system detects errors at its receiving end, it signals the transmitting error control unit over a narrow-band reverse channel operating on the same two-wire circuit used to transmit the data. The receiving buffer erases the 48 data bits of the word in error and the transmitting unit repeats several blocks for a second time, and again, if necessary.

### PhD-170 Random-Access Memory

*Bryant Computer Products  
Division of EX-CELLO Corporation  
Walled Lake, Michigan 48088*

Development of the first magnetic mass memory using positionable write/read heads to provide simultaneous, multiple access to a 172,800,000-bit information store was announced in May by Bryant Computer Products. Designated the PhD-170,\* the new memory—a rotating magnetic drum—was demonstrated to attendees of the INTERDATA 65—IFIP Congress Exhibit.

With its large storage capacity, unparalleled operational flexibility and high transaction rate, the PhD-170 is inherently well suited to a wide variety of memory applications including on-line reservations systems; buffer storage for scientific and edp computers, process controllers, and data communication terminals; information storage and retrieval systems for inventory control, banking and stockmarket transactions, insurance actuary calculations, and directory references; advanced telephone switching systems; and the like.

In conventional rotating mass memories, recording heads must be grouped into sets to economize on the number of selection and write/read circuits required. Because only one head from each group can be writing or reading actively at one time, the data contained in the storage tracks serviced by the other heads in the group are inaccessible. Theoretically, this

problem could be circumvented by providing two or more heads to service each track. In conventional rotating memories of equal capacity, however, the cost is prohibitive both from the standpoint of the large number of heads required and the elaborate multiplexing selection and write/read circuits involved.

These limitations do not exist with the Bryant PhD-170 because it uses from one to four access mechanisms to serve the entire information store of 2752 tracks. These mechanisms can be positioned and multiplexed to provide multiple, simultaneous access to the entire memory—a unique design concept that is both economically feasible and practical. Although it is the most advanced and sophisticated rotating mass memory ever built, the PhD-170 is the epitome of design simplicity. It consists of a 20-inch-diameter drum superfinished with magnetic alloy plating, one to four access mechanisms mounting 43 Uni-Just "flying" heads, and a Saf-Set head interlock. Drum speed can be either 1200 or 1800 rpm.

Each access mechanism, located at 90-degree intervals around the periphery of the drum, operates independently of the others and has access to all 2752 tracks on the drum. All heads on one access mechanism are moved together, each head being positioned to any one of 64 tracks by means of a precision digital actuator—a linear positioning device with 64 discrete stops. Also, the drum contains additional fast-access data, clock and register tracks capable of storing 6,000,000 bits of data.

\*The prefix PhD is an acronym for Positioning-head Drum and the number 170 indicates the order-of-magnitude of the drum storage capabilities in millions of bits.

By using multiple positioners, two, three, or four heads can gain access to the information in the same track at the same time. This means that track-to-track access time to the data store is limited only by electronic switching and latency times; this time is equivalent to having four heads per track, or over 10,000 heads to serve the 2752 track capacity of the PhD-170. Also, because each access mechanism has 43 heads, up to 172 tracks can be written on or read from without positioning. If desired, the PhD-170 can be programmed to serve as up to four independently accessible drums, each capable of storing 43 million bits.

In this operating mode, each drum can be separately addressed at a different frequency.

Transaction rates achievable with the PhD-170 are unprecedented. Using a 2000-byte message length, for example, a PhD-170 operating at 1200 rpm and with two access mechanisms can be multiplied to obtain an average of 198,720 transactions per hour; four access mechanisms would allow the drum to service two processors at this rate. At 1800 rpm and with three positioners, the drum will perform at the rate of 241,920 transactions per hour.

### Philco Visual Display System

*Carnegie Institute of Technology  
Pittsburgh, Pennsylvania 15134*

A computer-driven visual display system will be installed at the Carnegie Institute of Technology Computation Center in Pittsburgh during the summer of 1965 by Philco Corporation.

The complex cathode ray tube system, being built to Carnegie Tech's specifications, is one of the most sophisticated known today. The system was adapted from Philco's Real-Time Electronic Access and Display (READ) System by Jesse T. Quatse, Manager of Engineering Development at the Computation Center.

Dr. Alan Perlis, director of the Computation Center, believes this advanced system will provide a method for the more effective real-time use of time-shared computers.

The Carnegie Tech system, consisting of a controller and three consoles, will permit the operator to manipulate high-resolution alpha-numeric and graphic digital data in a volatile manner on the face of the cathode ray tubes. The university plans to use it for computer programming and program debugging; problem solving in engineering, mathematics, and science; and classroom instruction.

The system will be installed in a classroom building 1000 feet across the campus from Carnegie Tech's present multi-processor computer system (see DCN April 1965). Tech's data processing system has a common memory of 65,000 words, 8000 of which will directly communicate with the display system. A booster module and memory interface in the Center will

drive the signals to the Philco display equipment in the classroom building.

Each of the three consoles will be equipped with a cursor, a light pen and two typewriter keyboard. The cursor is an electromechanical locator which enables the operator to place a locator spot on the face of the tube. With it, data can be inserted, altered, or erased. The light pen can be used for the same purpose. The keyboards include all characters in the English, Greek, and Russian alphabets plus mathematical and special symbols.

The cathode ray tubes in each console have 80 square inches of viewable area (approximately 9 x 9 inches square). Information in one console may be simultaneously displayed on any of the other consoles, or each of the consoles may have a different display. Operators can insert, correct or delete data as well as reposition, intensify, blink (on-off), or vary the size of the symbols displayed on the tube, without computer intervention.

A typical problem-solving application will be the design and simulation of complex systems such as computers. A student could see the system he designed in operation on the face of the tube.

Philco's READ system, on which this Carnegie Tech system is based, is a product of the Communications and Electronics Division's Information Systems Department at Willow Grove, Pa. READ was introduced at the Spring Joint Computer Conference in Washington, D. C., in April 1964.

## Constructs, Computer-Directed Drawing System

*Control Data Corporation  
Minneapolis, Minnesota 55440*

A computer-directed drawing system, called CONSTRUCTS, which can produce detailed construction drawings 25 times faster than a draftsman was demonstrated in May by Control Data Corporation. The demonstration involved Control Data computers in the Company's Chicago and Minneapolis data centers and the use of long-distance telephone lines over which the problem and solution were transmitted.

CONSTRUCTS (Control Data Structural System) has already been successfully used to produce steel fabrication detail drawings for a multi-million dollar institutional facility to be erected on the east coast. The 150,000 sq. ft. structure will have between four and eight floors. The composite design calls for approximately 800 tons of high-strength and carbon steel, to be shop-welded and field-bolted.

The Belmont Iron Works, Eddystone, Pa., will fabricate the steel. George V. Robertson, Jr., vice president of the 95-year old firm, said: "The drawings produced by CONSTRUCTS were excellent and provided a drawing for the shop equal in quality and content to any produced by the conventional manual methods. Belmont, one of the top 10 independent steel fabricators in the country, foresees significant economies as a result of using CONSTRUCTS."

The CONSTRUCTS programming system is presently capable of handling more than 40 percent of the steel fabrication detail drawings required to construct a normal commercial or industrial building. Within a year this percentage will be more than doubled. A variety of non-building type structures can also be undertaken, as CONSTRUCTS also has the potential to be used for other kinds of mechanical and electrical drawing work.

CDC has been conducting exploratory work in computer-directed automatic design, detailing, and drafting for other industries. They are also perfecting new programs to design complex structures automatically. Future specialized extensions of CONSTRUCTS concepts will depend upon the interests of individual clients.

Utilizing the CONSTRUCTS programming system in the steel fabrication detailing application, the computer accepts basic design criteria and determines the exact dimensions of steel members, how they should be cut, and the size of the connecting members. The number of bolts and lengths of welds to be used to interconnect members are also determined.

CONSTRUCTS seeks out possible obstructions and connection problems, and automatically provides special solutions as required.

Once calculations have been completed, full-sized drawings are produced on a plotter, following currently acceptable practices for shop detailing. Drawings show accurate dimensions of each piece of steel to be cut and every connection, with proper allowance for all fittings. A complete, printed bill of materials can also be produced.

All this is done much faster, and with far less chance of human error than was previously possible. The great majority of this work is processed by the computer system in a continuous flow, with human intervention occurring only on sheets which require manual drawing of pieces such as hand rails, curb plates, and the like. Supervisory time can be limited to the point at which data is fed into the computer system, with assurance that the drawings produced will totally conform to input.

In the demonstration held earlier, design criteria were prepared and fed into a Control Data computer at the Company's Chicago data center and registered on magnetic tape. The data was then transmitted via Dataphone to a Control Data 3600 computer at the Company's Minneapolis data center. The 3600, a large-scale computer with 131,000 words of magnetic core memory and the capability of executing 500,000 instructions per second, constructed a mathematical model of the structure to be built, made all calculations and produced all plotter commands. These plotter commands were then transmitted back to the Chicago data center and recorded on magnetic tape. The magnetic tape unit, in turn, activated an Electronic Associates, Inc. 3440 mechanical plotter which produced the detailed drawings. Between 13 and 25 hours of drawing and checking--exclusive of supervisory time--are normally required to manually produce one drawing of one average steel fabrication. With the CONSTRUCTS programming system the same drawing can be produced at an average rate of less than one per hour, without human error.

The CONSTRUCTS programming system also promises to be a valuable aid to fabricators in estimating. The speed inherent in the use of CONSTRUCTS will enable a company to submit alternative and more complete estimates on a given job.



CDC believes that the computer-directed drawing system will have widespread influence on the steel fabrication industry. By using this new computer programming tool, detailing organizations can substantially increase their work capacity. Significant reductions in time should be realized between the initial design stage and the time mill orders are generated. To the draftsman or designer, CONSTRUCTS represents a means to eliminate repetitious routine drawing work. Ultimately, developments like this will result in a more efficient use of manpower skills and will at the same time upgrade the status of the engineer and technician. Experienced human judgement will remain essential.

The CONSTRUCTS programming system will be made available to customers in two ways:

either Control Data will assume total responsibility on behalf of a client for producing fabrication drawings, or will work with a client's staff to phase-in CONSTRUCTS where feasible using Control Data's computers and programs. A man familiar with detailing can prepare input data for the computer after only 4 hours of training, and he can work independently of the system after a 2-day training period.

The CONSTRUCTS programming system was developed by Meiscon Corporation, a subsidiary of Control Data Corporation. Meiscon is an industrial, civil, and computer applications engineering consulting firm established by Control Data to work with industrial clients and governmental agencies in the development of automated systems.

#### Traffic Surveillance System

*Control Data Corporation  
Minneapolis, Minnesota 55440*

Control Data Corporation, in April, demonstrated a computer-controlled traffic surveillance system which is to be installed in May at the National Proving Ground for Freeway Surveillance Control and Traffic Aids, Detroit, Michigan. This is a continuing research project aimed at devising and testing freeway traffic controls, surveillance equipment, and freeway design improvements.

Testing and surveillance are conducted on a 3.2-mile portion of the John C. Lodge Freeway in Detroit. The computer system will provide control of traffic conditions through ramp closures and speed sign changes along the test portion of the Lodge Freeway. The system will also gather traffic data to be used in continuing traffic engineering studies.

This research project at the National Proving Grounds is sponsored by the U. S. Bureau of Roads, the states of Michigan, Alabama, Georgia, Indiana, Louisiana, Minnesota, Missouri, Nebraska, New Jersey, Ohio, Pennsylvania, Washington, Wayne (Michigan) County, and the City of Detroit.

The demonstration of Control Data's computer-controlled traffic surveillance system simulated traffic information being received from 27 ultrasonic detectors located along the 3.2-mile test portion of the Lodge Freeway. From this information, the system computed the number of cars and trucks occupying various lanes of the freeway, speed of

traffic, and percent of pavement occupied. The system also controlled the ramp closure signs, as well as the speed signs for one of four speed-control settings. In addition, all information fed into the system was printed in the form of an operating log. The display portion of the system presented to the operator in chart form (1) actual vehicle speed, (2) posted speed, (3) percent of pavement occupied, and (4) volume of vehicles per minute.

A program will eventually be developed for the computer to process traffic data and issue instructions that permit automatic operation of the signal system. The activities of the National Proving Ground are expected to develop a highly refined system that will include integration of surface street traffic control with that of freeways, and the optimum efficient use of roadways with maximum safety provisions.

#### BACKGROUND

During the summer of 1955, The Detroit Department of Streets and Traffic and the Michigan Bell Telephone Company cooperated in a short test to determine the feasibility of freeway traffic surveillance by closed circuit television. Although the scope of the test was limited, the results encouraged efforts to obtain support for a more complete investigation. Since traffic surveillance is not an end in itself, but merely a means towards traffic control and

traffic research, the proposed project included provisions for a traffic control system of lane and ramp signals and variable speed signs, and for research into freeway traffic characteristics. Finally an agreement was reached to conduct an investigation into freeway traffic surveillance and control research on the John C. Lodge Freeway in Detroit. The cooperating agencies were the Michigan State Highway Department, the Wayne County Road Commission, the City of Detroit Department of Streets and Traffic, and the Bureau of Public Roads. The project was to last 2 years; control of the project was under the Michigan State Highway Department. The project was known as The Freeway Traffic Surveillance and Control Research Project.

In July 1959, work began on several phases of equipment requirements. It was necessary to determine the specifications for the television cameras, monitors, transmission system, and associated equipment. At the same time, work began on the requirements for the automatic traffic detection system and associated accessories, as well as the design of the traffic control system, the necessary signs and signals, and the operational concepts which would, to a large extent, fix the system.

In August 1960, the contract for the installation and 2-year maintenance of the television equipment was awarded to the General Electric Company. Also in August 1960, it was decided to locate the control room in the Herman Kiefer Hospital complex, approximately at the mid point of the study section. The Michigan Bell Telephone Company began laying a specially constructed cable on the freeway median. This cable was laid in two sections, each containing 75 pairs of conductors and 8 balanced pairs of video circuits to provide for transmission of video signal, camera control, detector information, and sign and signal operation. One section of the cable was laid from the control room north to the end of the project area, the other from the control room south to the Edsel Ford Freeway. Meanwhile development continued on the requirements and specifications of the automatic detection system, the freeway traffic control, and its associated signs and signals.

Installation of the camera equipment and the cable progressed rapidly; in October 1960 it was possible to transmit a live picture of freeway traffic to the Automobile Show at Cobo Hall in downtown Detroit. A picture also was transmitted to the AASHO convention in a downtown hotel in November 1960.

In November 1960, the General Railway Signal Company, in the process of designing and developing ultra sonic traffic surveillance equipment, offered to lend field and office equipment consisting of classification and speed (doppler) sensors, with the necessary relay racks, analog computers, and display panels. This generous offer was accepted and, since late in 1960, the GRS equipment has been used on the project at no cost. The television system installation was completed and the system was accepted late in December 1960.

Observation of freeway traffic began on a half-time basis as soon as the television system became operational. In May 1961, college students were hired as part-time observers and the system was used from 6 a.m. to 8 p.m., 5 days per week.

In January 1961, General Railway Signal Company was the successful bidder on the freeway variable traffic control system equipment. This award involved equipment to transmit control messages to the sign and signal locations in the field, log the transmission of such control messages and confirm the status of the field signs and signals. It did not include the signs and signals themselves.

The lane and off-ramp signals were awarded to three signal companies, one each for incandescent (Eagle Signal Co.), neon (Winkomatic Signal Co.), and fluorescent light sources, and later for a multi-lamp incandescent combination X and arrow signal (Roadway Control Corp.). Later an award was given for matrix variable speed signs to Eagle Signal Company.

In March 1961, the research program was begun with the collection of data for a series of travel time studies. Work has continued since on research into freeway traffic characteristics. By April 1962, lane and off-ramp signals and the variable speed signs had been manufactured and installed. Although it required from July 1959 to April 1962, almost 3 years, to establish an operating system of lane and ramp controls and variable speed limits on the freeway, it must be remembered that the entire system was designed with little or no previous experience to draw upon for guidance. The surprising thing is that it was accomplished so quickly.

On May 7, 1962, operation of the freeway traffic control system of lane and off-ramp signals and variable speed signs was initiated. Much has been accomplished since then in improving operating methods to increase the freeway efficiency.

In January 1963, the final set of control signals, the on-ramp closure signals, manufactured by Roadway Control Corporation, became operational. Thus in the relatively short span of 3-1/2 years an entirely new concept in freeway traffic control was developed from a basic, general concept of a closed circuit television surveillance system, a traffic detection and measuring system, and a remotely controlled freeway traffic control system. This has proved to be a well-conceived, complex system of visual and electronic surveillance and traffic control system with "fail-safe" and confirming features.

Since installation of the traffic control system, work has continued on developing improved instrumentation, on freeway traffic research and on improvements in operation methods of the control system.

In December 1963, the project became a national cooperative research project when the Highway Departments of Alabama, Georgia, Indiana, Louisiana, Minnesota, Missouri, Nebraska, New Jersey, Ohio, Pennsylvania, and Washington, joined the original four sponsoring agencies. The name of the project was changed to "The National Proving Ground for Freeway Surveillance, Control and Electronic Traffic Aids." A full time project staff was assembled from the Michigan State Highway Department and the Detroit Department of Streets and Traffic. Work has been progressing in two main areas: Traffic Research and Equipment Development.

A summary of the traffic research completed by both the John C. Lodge Freeway Traffic Surveillance and Control Research Project and the National Proving Ground for Freeway Surveillance, Control and Electronic Traffic Aids, which follows this short history, will provide an idea of the scope of the research work undertaken up to this point. In addition to the completed studies, work is scheduled on other subjects such as complete evaluation of all components of the control system, both as to the effect of their operation upon freeway traffic and of the equipment itself. Further work is required to gain as much information as possible about characteristics of freeway drivers as well as about "traffic" itself.

#### PROPOSED IMPROVEMENTS

Planning work now has been completed and additional new sensing equipment is being acquired to provide more complete freeway traffic information for optimizing the freeway control system and performing future research

work. Sensing equipment used in the past, while satisfactory, was insufficient in quantity and was not located in accordance with the demands of the control system. Operation of the control system has given needed direction for the proper placement of sensing equipment. Plans call for the installation of 28 detectors on the center lane of the freeway, divided evenly between the northbound and southbound directions. This will permit a sampling of the traffic stream so that speed, volume and lane occupancy information can be obtained from a single classification type ultrasonic detector.

To assist the operator in making the proper control responses, this information will be presented on a display panel or oscilloscope which will provide the operator with a histogram, or bar chart type of display, of speed, volume and lane occupancy measurements taken from the center lane. While the center lane may not always accurately reflect traffic conditions of adjacent lanes, we can refer to the television monitors to determine whether the center lane measurement represents an abnormal condition.

To reduce instrumentation cost and minimize the use of circuitry from field stations, either the northbound or southbound direction only will be displayed on the panel at one time. However, one station located midway in the project area will be displayed on the same panel to represent the traffic condition in the opposite direction.

Although the visual display information will be confined to 14 detectors, additional detectors will be available for measuring traffic conditions in the other lanes of the freeway. The Cornell Aeronautical Laboratory has been assigned Highway Research Board Project 3-2 which covers prediction of congestion on a freeway. In carrying out its work, C.A.L. will acquire 10 detectors, in addition to those installed by the project, which will gather the same traffic information from the curb and median lanes to provide five continuous sensing stations along the freeway.

The ultrasonic detectors, both of the classification and doppler variety, already installed at the Chicago Avenue bridge will be left in place. They will provide complete traffic information for all lanes at this station. (This station, incidentally, will be used as a permanent counting station representing conditions on an urban freeway. This will become a part of the statewide counting stations established for gathering traffic information.)

The portable detector mounts designed specifically for this project will permit future

changes in location of detectors to perform comprehensive traffic studies in certain areas. It is anticipated, however, that the center lane detectors will remain in place for the purpose of control.

The field information gathered from the traffic sensors will be brought to the control center where it will be classified, analyzed, and logged by a digital computer with its associated hardware. This computer will serve a three-fold purpose: It will provide a means of logging information, analyzing data, and providing outputs for both the control system and the visual display. The first assignment for the computer system will be to provide continuously up-to-date information to the display equipment for the operator. He will in turn interpret this information and perform the proper control functions.

It is hoped that this operation, i.e., the response of the operator to the data provided on the display, will result in a pattern of events and occurrences so that a program can be developed to process the original data and provide instructions to the computer to permit automatic operation of the signal system. To predict the course of the project activity beyond this point is, of course, to anticipate some of the results.

#### THE FUTURE OF TRAFFIC SURVEILLANCE & CONTROL

The project does have a definite goal and purpose. With this in mind, it is well to visualize the type of system which probably will evolve in the relatively near future. While most of the research up to this point had been confined to the freeway itself, experience already shows the wisdom of integrating surface street control with that of the freeway.

The ramp closure experiments showed the great value of improving the traffic operation of the surface streets when it is necessary to divert freeway traffic by ramp closures. It also is strongly felt that ramp closure by itself would never be successful unless the driving public is given a very definite alternate route to travel, either on a longer path back to the freeway or by surface street, to their destination.

Many lessons already have been learned on how to optimize surface street control. Certainly every effort will be made to take advantage of these results in the experiment in Detroit. Fundamental principles of good traffic engineering will be followed, such as the proper spacing of arterial streets, to obtain the advantages of progressive signal timing in a good

street system. One way streets will be employed whenever possible to conform to the same type of operation found on the freeway.

We are now planning to provide traffic responsive signal equipment for the surface street grid network which will have some unique features of operation. First, traffic sensors will not be placed at each approach leg to a signalized intersection but rather at points in the grid network where there are marked traffic changes, based either on demand or on capacity of the particular section of roadway to carry the traffic. The traffic sensor which will measure the input to one area also will be the measurement of output for the area from which the traffic came.

With this type of system, once an adequate measurement of the traffic stream is made and the traffic carrying capacity for varying conditions is stored in the computer, it becomes possible to derive an optimum timing sequence for the grid network. This means that a certain width band of progressive signal green can be given to the motorists traveling along a particular street and they would be instructed to travel at the appropriate speed consistent with the progressive speed of the signal timing.

The motorists would proceed through a series of minor signalized intersections where there is little interchange of traffic with the cross streets. However, if there is a major interchange of traffic at a particular signalized intersection, this would be a logical location to place additional traffic sensors to determine the traffic characteristics of the traffic stream. Such a system would require fewer traffic sensors which, in turn, would result in financial savings.

Although several signalized systems already use computers to derive optimum timing sequences, it is our feeling that the motorist could perform much more efficiently in the street pattern if he were included in the loop between the traffic sensors, the computer, and the traffic control system. For this reason, we intend to provide two types of information signs for the benefit of the motorist.

The first type would be variable speed message signs which will instruct the motorist on the proper speed to stay within the progressive green band of signal timing along the surface streets. We can extract the major advantages of the General Motors Pacer Signal System experiment by lighting the speed sign when the motorist is within the green band; however, if he approaches the signalized intersection when he is out of step with the green band, the speed

sign will be unlighted. This very simple signal display will permit the motorist to take corrective action to place him in step with the traffic system.

The second type of sign which we intend to use with the proposed system is one which will designate routes of travel from one part of the city to another and will show adequacy of traffic carrying capacity. For instance, let us suppose a certain section of roadway is being subjected to too much traffic pressure for its capacity. Since the traffic sensor already will have relayed this information to the control center where the computer can alert the control system to this condition, motorists then will be advised to use alternate routes with more adequate traffic carrying capacity.

This leads us to the third phase of the program, which probably will take us right to the last point where the man will retain control of his motor car or be locked into an electronic system which will take over his travel capsule and take him from one place to another without any decision on his part other than the determination of his original destination.

While maximum efficiency of operation of a road system is highly desirable, the same effort must be made toward obtaining the utmost safety in such a system. Control systems which require undue diversions of the driver's attention from his driving task are designed improperly. Also, a driver cannot operate properly in a control system if his mind is in a state of confusion caused by uncertainty as to his whereabouts. For this reason, we believe that the control system of the future must give the driver instructions as to his proper driving path along with instructions on how to drive this path to obtain real safety and efficiency from our system. Obviously a driver uncertain of his directions performs very poorly.

In the control system of tomorrow, we must have an accurate record of the location of all traffic sensors, roadways and traffic control devices. We also must know the whereabouts of the traffic demand. This would dictate the need of a simple route identification system which can be referred to not only by the computer but also by the drivers on the route.

Suppose route segments in an entire grid network of a city, which includes both the arterial streets and freeways, were identified by a systematic code which can be recognized by the computer and the driver alike. As an example, north, south, east, and west routes could be identified by easily identified color patterns. Each of these directionally oriented routes

could then be numbered consecutively from a beginning point.

The city likewise could be separated into various zones. These also could be identified for the driver visually when he passes from one zone to another. In the early stages drivers could be given route information by use of changeable signs to take them from one section of the city to another. Later, since the central control point would have all the traffic logic and identifications of routes at its command, there could be a simple system devised whereby a driver would have a device in his car from which he could request information on how to proceed from one part of the city to another. A recording device then would receive instructions from the central control system by some type of electronic pickup which would program a signalling device within the car to give the driver instructions on how to proceed along his route, when to make the proper turns, etc., to reach his destination.

In areas where parking is a problem and there are large off-street parking facilities, the driver even could be instructed on how to reach the available parking stall nearest to his destination. Parking garages already are equipped with information devices which tell them the availability of empty stalls. This system could be coupled easily to an external system giving direction to a motorist.

Although the problem on how to receive information in the vehicle may seem difficult at the present time, it is easy to envision locations where a driver could drive in and park over a induction coil which could give this information to the recording device in his vehicle. He would then pull out of this area and proceed on his path.

We now have completed the loop whereby traffic information is obtained from the street system and sent to the control center and instructions are sent to the driver from the control center on how to proceed best from one point to another. Therefore, he is totally informed on how to proceed through each portion of the city.

We even should be able to give the driver the anticipated travel time of the trip assigned to him. This should reduce speeding caused by the uncertainty of motorists as to their time of arrival since they now would know the best route and the best speed they can obtain through the programmed signal system.

The development of the described system leaves us with only one further step whereby

the man is removed from the actual control of his vehicle and automatic control is substituted. If development shows the desirability of this, a logical pattern already has been established on how to arrive at such a point.

The evolution of traffic control systems such as the one described will require technical developments in many areas. Control systems and computers are already at the point where the system described is totally feasible. Two of the biggest problems however, are in the field of traffic sensors and in the information giving devices. Development work has been performed already in these two fields on the Lodge and in numerous other experiments.

One noteworthy advance in traffic sensors which we feel is totally feasible (it also would be further justification of the use of a closed circuit television system) is a detector based on the extraction of traffic information from the television signal. This project has pioneered the efforts to obtain such a detector and we hope that funds for its development will be allocated in the very near future.

Various types of signs, both variable and animated, are being contemplated for use on the surface streets which will give not only the conditions of the freeway traffic but also of the routes along which the motorists must travel on the surface. Variable motor signs already have

been developed which could be very adequate for giving the motorist speed information along his traffic routes. This project is now working on a sign which will give information to the motorist on the condition of traffic on the freeway towards which he is headed. By receiving information from this device in an area of traffic freedom, he can plan an alternate route to avoid congestion.

Detroit has now established a "Traffic Central" system whereby traffic information is received about freeway traffic conditions both from the television center and from police freeway patrol vehicles. This information is relayed to a central point by radio and telephone communication. This is then placed on a closed circuit teletype system to commercial radio and television stations in the Detroit area. The motorist therefore receives the advantage of receiving traffic advisory information from all of the major radio and television stations which can aid him in planning his route. This already has proved its merit on numerous cases of accidents which have occurred. Advisory information has been given motorists on the restricted conditions of the freeway so that they can plan alternate routes through areas where there is less traffic congestion.

This project constantly has maintained a close liaison with industry to take advantage of

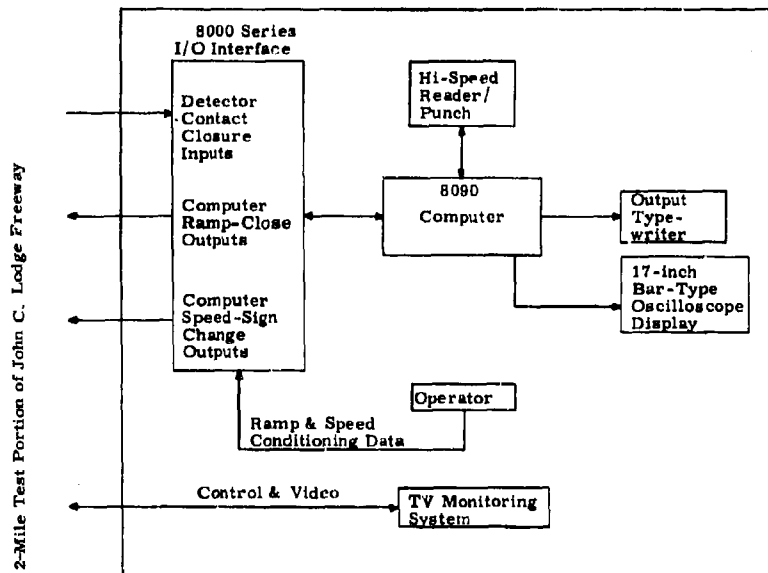

Operations Control Center/National Proving Ground for Freeway Surveillance, Control and Electronic Aids, Detroit, Michigan

the most recent developments in other areas which can be utilized in highway transportation. These efforts are paying off handsomely. Original development cost of some of this equipment would be prohibitive for highway budgets but it has been produced as a result of work and needs in other fields, particularly in national defense. Among the results of research are new equipment, new methods, new techniques, and new knowledge. The results of the research pro-

gram of this project include all of these. Much of the equipment now used, or being planned for use, has been developed or proven here. New data gathering methods have evolved from the use of closed circuit television for visual surveillance. Techniques of traffic control have been developed by the control operators and the success of these techniques is being proven daily.

### PLATO II and III

*Coordinated Science Laboratory  
University of Illinois  
Urbana, Illinois*

The purpose of the PLATO project (DCN, Oct. 1961, July 1962, and Apr., July, and Oct. 1964) has been to develop an automatic computer-controlled teaching system of sufficient flexibility to permit experimental evaluation of a large variety of ideas in automatic instruction including simultaneous tutoring of a large number of students in a variety of subjects. The PLATO system differs from most teaching systems in that the power of a large digital computer is available to teach each student since one such computer controls all student stations. The project work has fallen into three categories, no two of which are wholly separate from each other: (1) development of the tools for research; (2) learning and teaching research; (3) provision of a prototype for multi-student teaching machines. In all these categories of research the PLATO group has interacted frequently with various other groups at the University of Illinois that are concerned with curriculum studies, college teaching, and behavioral science research.

#### PLATO III--SYSTEM EQUIPMENT

During the first quarter 1965 work continued in the development and construction of circuitry required for the realization of a 20 student station teaching system.

Circuitry constructed to date increased the operable stations from 3 to 10. The construction remaining to complete the 20-student-station system is being continued and is expected to be completed by November 1965.

Performance of the present 10-station system is satisfactory. Each station, with the exception of a very small amount of video interference, executes all modes of operation properly and evidences no marginal operation under var-

ious conditions of operation with other stations. The matter of video interference is not especially noticeable or formidable and is consequently left for the future.

Development continues on special units which will up date present circuitry or provide special system facilities. Included are transistor deflection, power control, master keyset, and master video switch.

#### THE CATO SYSTEMS PROGRAM

Several minor errors in the CATO systems program were uncovered and corrected accordingly.

A compact routine called DUMPS, which dumps the specified portion of the memory onto the line printer in octal, was written and added to the FORTRAN RESIDENT. This is useful in code-checking CATO teaching programs since the routine does not destroy any part of the program as other existing dump routines do.

Changes in CATORES were made so that one may continue a lesson smoothly, with the minimum manual operations, after interruption of a run.

#### PLASMA DISCHARGE DISPLAY TUBE RESEARCH

The purpose of the plasma-display tube project is to develop an inexpensive substitute for the present PLATO memory-tube complex. As mentioned in the July 1965 Newsletter, one of the main problems remaining is the lowering of the firing voltage after a cell has fired. Previously, if the fired cell is extinguished and refired a few seconds later, any voltage between

the initial firing voltage  $V_f$  and the minimum sustaining voltage  $V_m$  will fire the cell.

During this quarter one cell was constructed which did not have these abnormal characteristics. Its firing voltage was 368 volts rms and the minimum sustaining voltage was 254 volts rms. Holding the cell's voltage between  $V_f$  and  $V_m$ , the cell remained out when it was momentarily turned out and it would remain on when it was pulsed on by the addition of another R.F. voltage to the sustaining voltage.

## PLATO LEARNING AND TEACHING RESEARCH

### Text-Tester

The TEXT-TESTER program was completed in January and tried out with a remedial arithmetic text developed at UICSM. Nine students from Hays School worked for 4 weeks on this material at the PLATO student stations. From this experience we have discovered a number of changes that need to be made in the TEXT-TESTER logic. Also we have accumulated a considerable amount of data stored on magnetic tape which will be useful in trying out the interpretation routines now being written.

### A New PLATO Tutorial Logic

A new PLATO tutorial logic has been written this quarter to allow greater flexibility and ease in the preparation of lesson material. In addition to magnetic tape input of parameters, the program allows the lesson writer to enter parameters from any PLATO student station where students are using the other stations. Thus, if an author has his lesson material designed sufficiently in advance, he need not waste computer time inputting and testing parameters. Parameter input from the keyset may also be stored directly on magnetic tape.

Other features of the program not included in previous tutorial logics are:

1. As many as 200 judging subroutines. At present there are eight judges and more are being written for future use.
2. Recognition of specific wrong answers for which special help may be given.
3. Plotting of network functions with student parameter control. As many as seven functions may be included in each lesson.
4. The choice of one of eight logic branches for each control key on each page of the program. Thus, in lieu of the normal function of a key, one of seven special functions may be chosen for each main page.
5. The ability to give any particular student extra material under computer control. If, for example, a student is progressing very rapidly, the computer can choose to give the student extra work of greater difficulty.
6. Provision for every student to be able to make comments at any point during the lesson.

### EE 322, Circuit Analysis

Eight Electrical Engineering students are taking the first University of Illinois course given for credit which uses the PLATO teaching system, EE 322, Circuit Analysis. The students have two lectures in the classroom and two lessons using PLATO each week. A new PLATO tutorial logic (see previous section) was written for the course. An interesting feature of each PLATO lesson is the "Comment" option which allows a student to type comments on the lesson or course at any time. The comments are recorded with the rest of the student's record and are retrieved after each lesson. They are useful for improving subsequent lessons as well as being of value for the course revision to be carried out next summer.

**Patient Account System**  
Jefferson Medical College Hospital  
Philadelphia, Pennsylvania 19107

In April, Jefferson Medical College Hospital announced that they were using an IBM 1401 computer system for automatically handling patient accounts. This system has been operating successfully since mid-February.

The first benefit to patients is faster information. They can now provide patients, at the time of their departure, with a more understandable and detailed bill reflecting all service performed while they were in the hospital. This



was largely impossible in the past because of the volume of paperwork involved and the time required to handle it.

A major problem facing hospitals today is the growing volume and complexity of paperwork in direct relationship to the advances in medical care. This results in the complication of maintaining precise and up-to-date records on all patient accounts. On an average day Jefferson must handle 3500 requests from a total list of 5000 services. Last year, for example, they had 700,000 requests for laboratory examinations alone. Maintaining accurate records for billing and for statistical purposes thus becomes a monumental but still routine job.

The unique part of the Jefferson installation is a network of 36 transmitting devices (IBM 357 Data Collection Units) positioned in nursing stations and other key areas throughout the hospital. These allow for the instantaneous transmission of information from remote areas directly to the computer room.

When a Jefferson patient is admitted, an admission form is prepared and sent to the

computer room. Here, the patient's name and identification data are fed into the computer, which stores it on a magnetic disk. A space is left behind the patient's name for additional information about his activities in the hospital.

The patient also receives an identification badge. Following the request for a service of some kind, such as a laboratory or X-ray examination, the nurse on his floor takes the badge and a card identifying the service and feeds this information into one of the transmitting devices.

This device relays the information to the computer room where the information is automatically punched into cards. The cards are "read" into the computer, which automatically prices the service, enters the information behind the patient's name on the magnetic disk and updates statistics.

Prior to discharge, patients' bills are automatically prepared by the computer at a rate comparable to typing 24 double-spaced pages in 1 minute. The complete, detailed bill is presented to the patient at discharge.

**Computing Center**  
*University of Kentucky*  
*Lexington, Kentucky 40506*

A Program of undergraduate courses designed for candidates for the bachelor's degree in computer science is offered at the University of Kentucky. The courses were developed to provide the student with an understanding both of the structure of the computer and of the representation of the problem. Basic courses are concerned with algorithmic descriptions of problem solutions, the logical organization of computers and computer hardware, machine language and symbolic instructions, input and output subroutines, interpretive routines, assembly programs, and macros.

More advanced courses will allow the student to study structure of information sets, files, arrays, trees, and lists; types of records and their functions; transferring of data from one file to another; and sorting and merging files.

Other courses for the advanced student will cover definition and writing of compilers and

the hierarchies of languages, analog techniques, and analog simulation on a digital computer, list structure and processing techniques, and the study of the total computer system including time-sharing and executive routines.

Computer science students will be able to do independent work on computer research problems approved by the department chairman, and participate in a seminar which will discuss current research papers and advances in computer science.

The facilities at the Computing Center include a 1620 with card input-output, and a 1401, 1410, and 7040 each equipped with card read-punch, magnetic tape, and high speed printer. Some experimenting is being done in teleprocessing, time-sharing, list processing, and artificial intelligence.

### Computer-Aided-Instruction

*University of Louisville  
Louisville, Kentucky*

The University of Louisville engineering school is approaching final resolution of a new concept in engineering education utilizing an IBM computer and a closed-circuit television network.

The Dean of the Speed Scientific School (Engineering) has announced that preliminary testing of the teaching system is now under way. It is expected to be fully operational by fall 1965.

One of the uses for which the system is designed is to allow engineering students to observe, "live," the mechanics of testing their laboratory experiments on a computer and to permit immediate modification of input information. The television network will also permit classroom and auditorium audiences to observe experiments being conducted in other courses at remote locations.

The computer being used in the Speed School's engineering education program is an IBM 1710 process control system. The system automatically accepts analog signals representing measurements of variables such as temperatures, pressures, flow rates, product qualities, loads, and other information needed to determine optimum condition of operation or design.

Special feature of the Speed School's system will be a "cabling system" whereby instruments and controls located in the laboratories will make it possible to signal measurements directly to the computer for immediate calculation and correlation. Furthermore, they will have the capability for modifying input information in order to observe how the final results

will be changed. Results of experiments will be flashed directly from the computer back to the classrooms via television.

One projected use of the new educational system is to program the computer to direct experiments by automatically changing temperatures, mixtures, pressure rates, or liquid flows.

It is claimed that the new system will be unique in engineering education. Neither television nor the computer is particularly new in the scientific education field. The value in Louisville's system is the use of television to make results available quickly to many people in many locations.

Another possibility is "instant testing" of students. Faculty members may want to know if students understand a specific topic they have just covered. Questions could be answered by students punching cards. Cards would then be processed by the computer, scored and results returned by television. If scores are generally poor, teachers will know that students have not grasped the subject matter.

It's even possible that daily quizzes of this type may replace some regular exams. This means students would know how they are doing on a day-by-day basis.

The system will also be used to bring to students a wide variety of subject matter not now included in the Speed Scientific School curriculum. The range of application depends only on the imagination of faculty and students. Some of the future uses of the system cannot even be anticipated.

### Time Sharing System

*University of Michigan  
Ann Arbor, Michigan*

Computer productivity at The University of Michigan will be increased by a factor of six to eight times for thousands of campus users through the computer concept called time-sharing.

Time-sharing is an operation in which a single computer system allocates "slices" of time (measured in millionths of seconds) on a rotating basis to many users, who are simul-

taneously working many kinds of problems requiring many different computer functions.

The speed of operation is of such a magnitude that each user feels he has the full power of a large scale system at his disposal. Furthermore, machine reaction times are so fast that individual users don't even realize many other users may be on the system simultaneously.

The University announced in April that arrangements have been made with International Business Machines Corp. for the acquisition of a System/360 Model 66. First units of the system will be installed in November 1966 for the initial time-sharing operation. Additional equipment will be installed in 1967 to create a dual system—in effect, two computers which may operate together or independently.

This decision by the University was taken only after a campus-wide committee of key faculty members, headed by Prof. Donald Katz, had reviewed the computer needs and requirements for instruction in the years ahead.

Specifications for equipment to meet these requirements were then written by U-M Computing Center staff members, and various systems were evaluated against these specifications.

The IBM time-sharing system has the capacity to handle our present requirements and can be expanded to satisfy our foreseeable future needs.

Two key developments in widespread computer usage at U-M were a result of research by Computing Center mathematicians, notably Bruce W. Arden, Dr. Bernard A. Galler, Franklin H. Westervelt, and Robert M. Graham now at the Massachusetts Institute of Technology Computation Center.

The first of these was the MAD (Michigan Algorithm Decoder) language. This is a simple system for describing, in language the computer can accept, the problem to be solved and the steps the computer must take in solving it. The language has few constraints on the user and can be quickly translated by the machine into its own particular set of instructions. The simplicity of MAD was instrumental in facilitating computer usage by large numbers of students, both undergraduate and graduate.

The second major contribution was the "Michigan Executive System," a set of instructions stored within the computer to guide it in the selection and solution of problems. Such a program is necessary to enable the computer to regulate itself in the storing and handling of large numbers of programs such as originate with students, faculty, and researchers.

MAD and supporting systems programs are being converted for use in time-sharing.

In addition, a 3-year, Ford Foundation-sponsored project on the use of computers in

engineering education led to widespread demands for more computer usage by undergraduates. This million dollar research and development effort was headed by Prof. Donald L. Katz of the U-M Chemical and Metallurgical Engineering faculty.

During this project, methods of teaching the use of computers to undergraduates were tested and developed, and faculty members from both the U-M and many other campuses throughout the country were instructed in teaching methods. Today, students in 72 engineering courses at the University use computers for their "homework."

More than 2000 students in 133 different courses now require the use of a computer to complete their class assignments. While this is believed to be the highest number of students on any college campus requiring the use of a computer for routine studies, the number is expected to increase dramatically with installation of the time-sharing hardware.

First, there is a small but fixed amount of time required to start the computation of any problem. For small problems, this "overhead" may exceed the time for the solution of the problem itself. In current systems, this limitation may restrict the number and size of the problems that can be handled economically.

Secondly, the diverse range, as well as the large number of users, puts demands on a system which cannot be met by computers at a single geographic location. On the other hand, a proliferation of smaller machines throughout the campus would spread resources too thinly.

The time-sharing concept, using remote terminals, is ideally suited to solving both of these problems. The geographical problems become non-existent, because users at terminals can operate just as though they were at the control console of the computer. Furthermore, because of the flexibility of the system, complex problems requiring large time segments for calculation can be worked on by the computer without interfering with smaller problems being worked simultaneously in other areas of the system.

The IBM System/360, which operates in a "conversational" way with each terminal, will instantly acknowledge data entry and check for clerical or logical errors. For the student user, this means he can immediately overcome the time consuming function of pinpointing initial errors in programming. Hence, overall problem solving times can be reduced from a matter of days or hours to only minutes or seconds.

Ultimately, results of the immediate checking and multi-processing capability will be a major reduction in "overhead" operations on the central computer when it is performing unproductive "housekeeping" functions.

Computing Center staff members have pointed out that there are two major requirements of a successful time-sharing system:

1. Modularity. In order to permit growth in response to demand, the system must be capable of accepting additional processors and uniformly addressable storage. It is necessary for principal components—processors, storage, and channels—to have multiple, uniform interfaces and that channel-processor connections be well defined in a multiprocessor system.

2. Address translation. By use of an exclusive address translation feature in the System/360 Model 66, the user can write his program with a maximum of ease and flexibility. A combination of hardware, the use of a new associative memory technique, and software, transfers the burden of assigning and keeping track of physical addresses from the user to the computer. With this feature, physical addresses are not assigned until the moment of execution. Furthermore, they may change dynamically as the user's program progresses. The user also has the ability now to visualize a "virtual memory" larger than the physical memory of the machine. The address translation feature will even assign actual locations in this case. Another advantage of the limitless memory technique is that it permits user programs to expand and contract in a flexible fashion without having to allocate a maximum amount of memory for each program.

A descriptive analogy for the advantages of virtual memory programming used in conjunction with the hardware-assisted translator is that of a loose leaf notebook. In the IBM time-sharing computer, a page can be inserted anywhere in

the book at any time, but with the advantage of automatically updating the index as each page is added.

There is also an additional advantage. With many people sharing the machine, there is a high probability that many are using the same program compiler—FORTRAN, for example. In the time-shared system, it is only necessary to have one copy of the program compiler stored in memory and shared by all.

The special programming techniques and hardware are particularly important in time-sharing operations because of the necessity of having any or all parts of a user's programs and data available for processing as his "time slice" comes around.

By the end of 1967, The University of Michigan's System/360 Model 66 will include two central processing units and more than one million characters of core storage. It will also have mass disk and drum storage as well as tape drives. Terminals will include typewriter-type machines, visual display, and graphic data display devices, and real-time data acquisition systems.

Two channel controllers will be used by the system to monitor priorities of data moving between the two central processing units and the storage devices.

The major considerations in selecting the IBM time-sharing system were: reliability, growth potential, and flexibility—to partition, to have two processing units work on the same problem, or to work different kinds of problems at the same time.

From the system the University expects more direct personal interaction between student and/or faculty users and the computer increased productivity for users and improved quality of output.

**Automated Laboratory Data Handling**  
*Medical Center*  
*University of Missouri*  
*Columbia, Missouri*

Automated laboratory data handling, a computer application still in the dream or planning stage at most hospitals, is a reality at the University of Missouri Medical Center. In May, officials of the School of Medicine demonstrated a computer based system that evaluates laboratory tests for accuracy and content; auto-

matically reports the results of these tests to the proper patient floor; stores in an electronic memory all information contained on each of these tests; and has the capability of making any part of this accumulated data instantly available for teaching, statistical, diagnostic, and research purposes. Key features of this advanced system

are IBM 1092 data transmission terminals, located in each of the hospital's five laboratories, and a 1410 computer with vast direct access memory capabilities.

This work is supported by a grant from the Bureau of State Services of the U. S. Public Health Service, and is under the direction of Dr. Donald A. B. Lindberg, assistant professor of pathology and director of the Medical Center computer program.

Results of laboratory tests are recorded in the computer simply by pushing a few buttons on the 1092 terminals. This causes a punched card containing all the pertinent information to be created in the data processing department. At regular periods during the day, these cards are entered into the computer which then subjects the tests to highly developed screening procedures. The Center has built into the system a series of parameters to which each test is applied. If the computer finds a test to be normal, results are transmitted by printer to the proper patient floor to be included in the bed chart. If, however, results are found to be 'abnormal or preposterous' they are subjected to reviewing procedures which might even call for a rerun of the test or a visit to the patient by the resident pathologist.

Dr. Vernon E. Wilson, dean of the school of medicine, said the system, one of the first of its type and one of the most advanced in the world, is significant because of its successful application in two broad areas:

First, the Medical Center performs more than 500,000 laboratory tests each year, an unusual number for a hospital this size. The computer relieves the lab pathology directors of a tremendous amount of detail and pinpoints the patients whose problems require immediate action. The system also frees valuable time of other medical, technical, and nursing personnel by speeding compilation, transmission, and receipt of data.

Secondly, but equally important, is the system's effectiveness in the area of education. Doctors Donald Lindberg, William D. Mayer (associate dean of the school of medicine), and Fred V. Lucas (professor and chairman of pathology) have received a \$45,000 grant from the National Fund for Medical Education to study the use of computers in a medical student pathology teaching program.

By training medical students in computer use now, they hope to produce doctors who will be philosophically oriented toward applying these

valuable new tools. In addition they are depending on the current students to generate ideas which will help set up the most effective procedures for future students. The 'case study' teaching technique presents students with a need to inquire into past experience with similar cases. If the computer can reply to the student's question in 20 lines or less, the answer comes back in seconds at the inquirer's terminal. If the answer is longer, it is printed out on the IBM 1403 printer in the data processing department.

The University Medical Center now has remote terminals functional in three of its five laboratories—chemistry, hematology, and bacteriology. The remaining two labs, clinical microscopy and serology, are expected to be operational in the very near future.

The laboratory data handling system subjects information from newly-completed tests to highly critical screening procedures. These involve factors such as age, race, and sex of patient; previous patient diagnosis and relation of new test results to earlier ones; accepted normal range of values; relation to the frequency distribution of results at the Medical Center; and biological properties of bacteria and antibiotics.

Based on application of these limits to each test, the 1410 computer then:

- Transmits each "normal" test result to one of nine printers located at nursing stations on patient floors. This data is for inclusion on the patient's bed chart.
- Transmits tests that exceed limits to the patient floors in the same manner, but also lists them each evening on a computer print-out for review by a pathologist.
- Transmits tests with highly abnormal, dangerous, or "preposterous" results directly to a reviewing station in the laboratory that made the test, but NOT to the patient floor. A resident pathologist checks each reviewing station periodically and, based on the data reported, he can visit the patient and/or order a test rerun. He may erase the previous test information from the computer simply by pushing a few buttons. Or, the resident can approve release of the test result to the patient floor, in which case it will be transmitted in the normal manner.

An example of the type of test that would go back to hematology for immediate review would be one reporting a white blood cell count of 200,000 per cm, indicating leukemia. Normally, the resident will order the test repeated on the same or a different sample unless he knows it is a valid result.

If the computer had previously processed test results indicating a diagnosis of leukemia for that patient, the report would not be rejected, but would automatically be transmitted as a routine test result.

All cases at University Hospital, a 441-bed general hospital, are referrals—often patients with difficult medical problems. Consequently the patients may be seen by a large number of doctors who often must order an unusually large number of lab tests—about 500,000 each year.

Consequently, the 'exception reporting' features of the IBM system relieve the institution's pathology laboratory directors of a tremendous burden of detail, pinpoint the patients whose problems require immediate review, and give the pathologists time to see them.

In addition, a series of built-in accuracy checks, plus the accuracy inherent in computer equipment, provide more precise screening than in the past. The system also speeds compilations, transmission and receipt of data, freeing the valuable time of other medical, technical, and nursing personnel.

Examples of the project's time-saving features, are three daily summaries of the laboratory operation that are automatically prepared by the system. They are: The previously described listing of abnormal results; a total recap of the daily work of the three labs now connected; and a listing for each out-patient clinic of the results of laboratory tests for patients treated in that clinic. In addition, all lab data transmitted over the system are automatically added to a clinical laboratory file which is stored on magnetic tapes. This includes:

- Patient discharge diagnoses and surgical operations for all in-patients since the hospital was opened in 1955 and previous records for a former hospital. This also includes county of residence, hospital care days on each service, and/so on.
- A surgical pathology diagnosis file, containing data on 50,000 tissue specimens.
- A tumor registry file containing patient numbers, origin and diagnosis of tumors, therapy and, in some cases, follow-up data for every patient with a neoplasm.
- Master reference file, containing coded data on birth date, race, sex, and blood type for every patient ever treated in the hospital.
- Data from the American Medical Association manual on "Current Medical Terminology,"

which includes the names of diseases, etiology, symptoms, and so on.

Also stored in the computer are a radiology file, containing the physician's interpretation of each roentgenogram since 1955; and an EKG file, containing some 60,000 electrocardiograms, coded by cardiologists according to 105 categories.

The ability to keep the file of patient information constantly and automatically updated and readily accessible is probably the most important aspect of this computer-communications system. While computers have most frequently been applied to the support of medical research, this program concerns itself with their use in medical practice and teaching.

#### APPLICATION OF THE SYSTEM TO MEDICAL EDUCATION

While computer systems have been successfully applied to a number of problems in medicine, the proper use of these devices for teaching medicine is still under experiment. A new and unusual attempt in computer teaching is under way at the Medical Center. Here the computer is used mainly as a means of selective retrieval of information amongst the mass of facts about the symptoms and treatment of all patients seen at the institution.

With the computer programs it is hoped that medical students can examine the history of medical care in their own institution, in order to deduce new and old medical principles. In addition, the system must help develop doctors who recognize the potentialities of computers and can use this important new medical concept.

About 40 students, half the class in second year pathology, are participating in the project. The courses in anatomic and clinical pathology are totally blended and taught by the "case study" technique. Students are assigned to, and study, hospital patients whose diseases match those under study during a given week.

In the work-up of each case, students perform the appropriate laboratory examinations. This presents them with a real need and desire to inquire into past experience with similar patients and other laboratory procedures. Formerly, students could go to instructors or published literature for answers to questions. Now, under the new system, he also has access to the patient care data and other medical information stored in the computer.

Communication with the computer is provided for the student via an IBM 1014 remote inquiry terminal, similar in appearance to an electric typewriter. By keying in the name of the particular clinical program and specific test results, the student gets back a wide variety of information. In addition, most questions can be handled in a more traditional manner by asking the student to write out the question in English on special forms, batching the questions and then entering them in the computer via punched cards.

For instance, a student might call for a list of diagnoses of patients with similar test results, number of cases studied, and how his patient's results compare with norms. Or, he might ask for a list of patient numbers so he can obtain the records for study. Or, in another area, a

differential might be requested, listing diseases indicated by the tests, with the most likely ones first.

Among the problems now being resolved is that of teaching students how to communicate with the computer. To date, all of the students have learned to ask key questions in the right terminology.

Looking into the future, the Medical Center envisioned several additional important applications. For instance, ultimately they hope to add the MEDLARS index of scientific and medical periodical literature as compiled by the National Library of Medicine. If this information were in storage, as the computer printed facts for a student it also could list all pertinent articles relating to the case.

## MAGIC

National Bureau of Standards  
Washington, D.C.

The Computer Technology Section of the National Bureau of Standards is currently engaged in an extensive program to develop advanced techniques for improving user communication with large ADP systems. Applications of ADP systems such as command and control, design and mapping, utilization of active files, editing, and information retrieval requires that data processing capabilities be made accessible to users who are essentially task-oriented, rather than machine-oriented. This in turn requires the development of simple, effective techniques for achieving communication between the data processing system and the users.

This summary briefly describes a machine which has been developed within the Computer Technology Section as a research tool for the investigation of man-machine communication techniques. This machine has been designated MAGIC (Machine for Automatic Graphics Interface to a Computer). MAGIC combines large-diameter cathode-ray displays with a specially designed programmable digital computer. It is designed as a remote display station and is intended to be connected to a large ADP system via voice quality communication lines. Extensive design effort has been devoted to removing from the ADP system the time-consuming and repetitive tasks of display regeneration and manipulation, and to minimize the limitations introduced by the communication lines. Particular emphasis has been placed on establishing the

proper balance between hardware and software functions. The final design specifications of MAGIC evolved from a number of basic considerations such as memory type and organization, display type and control, word formats for the machine instruction and display data, operator controls and system economics.

### DISPLAY DATA ORGANIZATION

Digital data required to drive a display generally exists in a serial list form with respect to time. Therefore, it would seem logical to generate, manipulate, and store display data with a processor having list processing abilities. Display data within MAGIC consists of three lists: the X coordinate field, the Y coordinate field, the the Z (display characteristic) field. The X and Y coordinate data consists of 10 bits centered in the 12 bit display data word. This allows an increase in display size by a factor of two without loss of coordinate data bits by utilizing list shift instructions. Display characteristics include intensity level, alphanumeric character and character size and plot mode (line, dashed line, and point). A magnetic drum incorporated in the system provides general memory storage for use by the control processor and display memory storage for display data manipulation by the subordinate list processors. The drum revolves at 1800 rpm, providing a display refresh rate of 30 frames per sec.

## SYSTEM HARDWARE ORGANIZATION

There are two major hardware sections of the MAGIC system: the display unit and the processor unit. The display unit consists of a primary and a secondary CRT display. The operator uses the primary display and its associated controls to perform the majority of his communications with MAGIC. The secondary display is used as a passive display device only.

The processor unit is subdivided into one control processor and four identical subordinate list processors designated W, X, Y, and Z. The control processor contains all registers and control logic necessary for executing programs within the control processor and for controlling the subordinate list processors. The subordinate list processors X, Y, and Z operate directly on the portion of memory from which the primary display operates. Subordinate list processor W is considered part of the control processor and allows the control processor to perform list manipulations without disturbing the primary display.

## INSTRUCTIONS

The instruction repertoire of MAGIC may be divided into two categories: non-list instructions and list instructions. Non-list instructions pertain primarily to the control processor. The list instructions in MAGIC pertain to the subordinate processors. These instructions may be subdivided into six categories of list manipulations: insert, delete, shift, addition, scan, and memory-to-memory ("block") transfers. Only one machine

language instruction is required for each list manipulation. The unique hardware design of the subordinate list processors allows true list manipulations to be performed on the data in display memory.

For example: The execution of an insert instruction will replace the contents of a specified sector of a display memory channel with new data and automatically move the previous contents of that sector and all following sectors down one sector to accommodate the inserted data word. This is a true list insertion.

## OPERATION

Two fundamental functions of MAGIC are the generation of display data and the manipulation of display data. For these purposes, the user has at his command a light pen, a displayed cross-hair "locator" which may be positioned with the light pen, manual switch controls for specifying display characteristics, and 63 internally programmed interrupt pushbuttons for executing desired display manipulations.

## STATUS

MAGIC was originated in August 1964 and became fully operational in February 1965. It is currently being used to conduct experiments and perform demonstrations in order to better define the optimum characteristics for equipment of this type. The development and programming of MAGIC has been supported by the National Bureau of Standards and by the National Aeronautics and Space Administration.