

P16



NATIONAL SECURITY AGENCY  
FORT GEORGE G. MEADE, MARYLAND

# CRYPTOLOG

## APRIL 1983

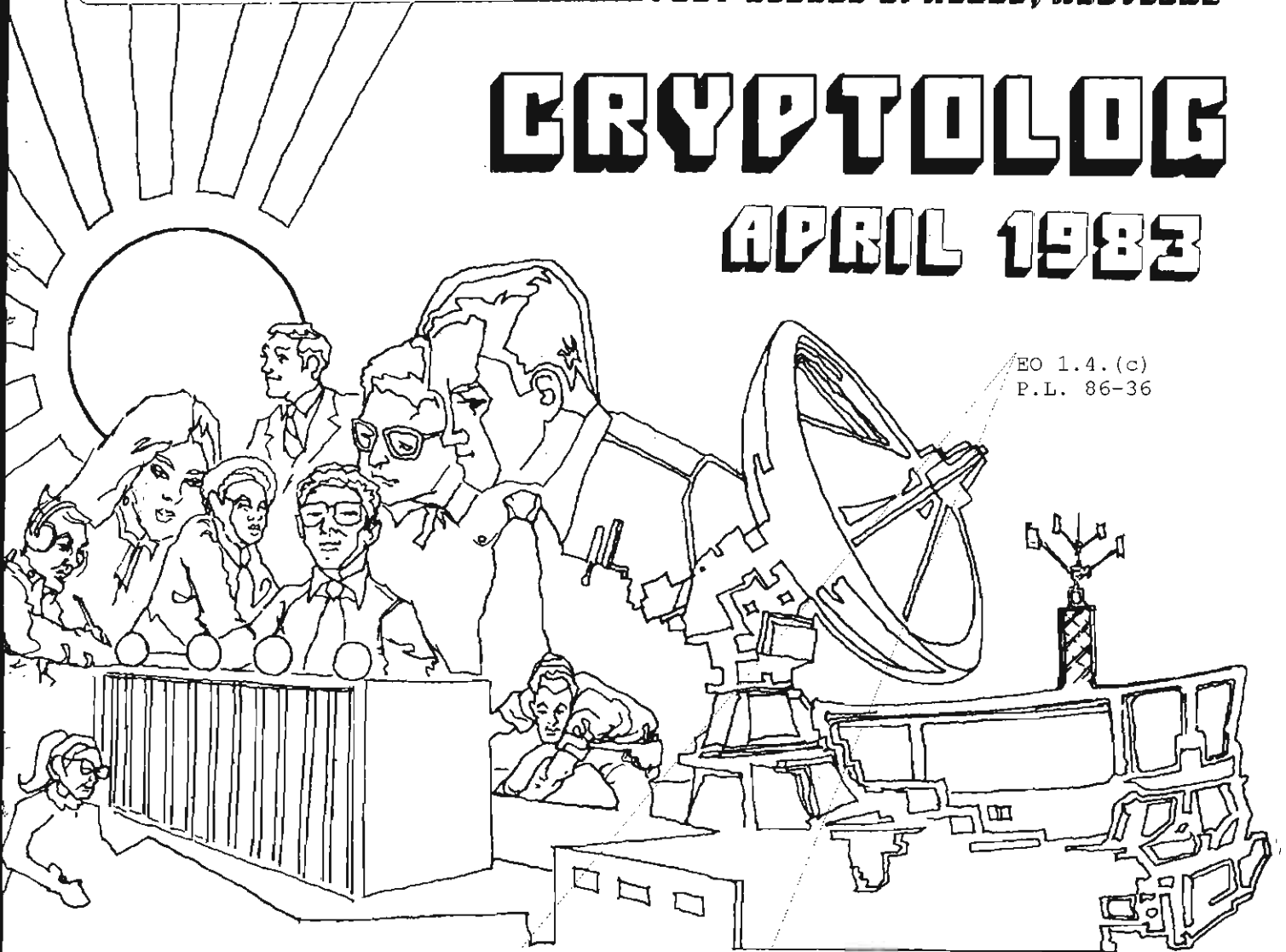

EO 1.4.(c)  
P.L. 86-36

UIS : USER INTERFACE SYSTEM (U)	
PART ONE: CONCEPT (U).....	[REDACTED] ..... 1
PART TWO: ARCHITECTURE (U).....	[REDACTED] ..... 11
CUMULATIVE INDEX, PART TWO: TITLES (U).....	..... 19
GOVERNMENT OF THE PEOPLE, BY THE PARTY, FOR THE LEADERSHIP (U).....	[REDACTED] ..... 30
SPECIFYING COLORS FOR COMPUTER GRAPHICS (U).....	[REDACTED] ..... 37
[REDACTED] .....	[REDACTED] ..... 39
[REDACTED] .....	[REDACTED] ..... 48
NSA IN THE SPACE AGE (U).....	[REDACTED] ..... 51
MY STAFF--IT COMFORTS ME (U).....	'Zebulon Zilch'..... 55
WORD PEOPLE AT NSA (U).....	'Dickson Airy'..... 59
NSA-CROSTIC NO. 46 (U).....	David H. Williams..... 60

P.L. 86-36

~~THIS DOCUMENT CONTAINS CODEWORD MATERIAL~~

~~TOP SECRET~~

~~CLASSIFIED BY NSA/CSSM 123-2~~  
~~DECLASSIFY ON: Originating~~  
~~Agency's Determination Required~~

# CRYPTOLOG

Published by PL, Techniques and Standards

VOL. X, No. 4

APRIL 1983

## Editorial

PUBLISHER

[Redacted]

### BOARD OF EDITORS

Editor..... [Redacted] (968-8322s)  
 Asst. Editor... [Redacted] (963-1103s)  
 Production..... [Redacted] (963-3369s)

Collection..... [Redacted] (963-3961s)  
 Cryptolinguistics [Redacted] (963-1103s)  
 Information Science  
 ..... [Redacted] (963-5711s)  
 Machine Support..... [Redacted] (963-4953s)  
 Mathematics..... [Redacted] (968-8518s)  
 Puzzles..... David H. Williams (963-1103s)  
 Special Research..... Vera R. Filby (968-7119s)

The other day we saw a phrase that we haven't seen for a while: "paperless office." It was a popular term a while back, and was sometimes called the "paperless society." It was used to refer to that future day when all paper would be replaced by some other media, such as cathode ray tubes (TV) or other display devices.

Just to see if something was happening that we hadn't heard about, we took a stroll through the local supply room. The shelves were still filled with paper supplies, and with things that make marks on paper. Looseleaf notebooks seem to disappear from the shelves as fast as the supply folks can stock them. One can still hear serious debate about which brand of "white out" does the best job. Erasers, paper clips, rulers, IN (and OUT) baskets, sheets of press-on letters, scissors...the list goes on and on. Paper does not seem to be on the way out just yet. Not around here, anyway.

For subscriptions  
 send name and organization

to: CRYPTOLOG, P1  
 or call [Redacted] 963-3369s

P.L. 86-36

There is a growing sentiment that we will never reach that paperless state. It is not, after all, a question of technology. In a recent survey of computer editing systems, the authors finished with the somewhat guilty admission that, in the preparation of their report, they had consumed just under a mile of paper. We have no statistics to support it, but we have the distinct impression that we are using more paper per capita, not less.

To submit articles or letters  
 via PLATFORM mail, send to

cryptolg at barlc05  
 (bar-one-c-zero-five)  
 (note: no '0' in 'log')

New technology does not have to replace the old; it sometimes finds its niche alongside the old. Office automation seems to be aimed at getting machines to write down, on paper, what used to be written down by some other method, on paper. Some people think office automation will use more paper, not less.

Contents of Cryptolog should not be reproduced, or further disseminated outside the National Security Agency without the permission of the Publisher. Inquiries regarding reproduction and dissemination should be directed to the Editor.

The next time you wander through your favorite supply room, take a close look at the tiers of forms arrayed there. Do you think they will ever go away?

by  T44  
and  T44SA



# QUIS

## USER INTERFACE SYSTEM

## PART ONE: CONCEPT

by 

P.L. 86-36



~~(FOUO)~~ The National Security Agency Scientific Advisory Board just published a Report on Networking Architecture which should be of special interest to you if you are a user of terminals and computers. It recommends that we develop an architecture which makes it possible to put effective access to data and computing within reach of every analyst who can use it. I would broaden that to include programmers, managers, technical staffs, and the hundreds--perhaps thousands--of people who deal with finance, training, travel, supply, and other essential support services both here and in the field. UIS (Users' Interface System) is that architecture and the subject of this talk.

~~(FOUO)~~ It seems to me that there are at least three questions worth asking about UIS:

- [1] First, what is UIS? In many respects, this is the easiest question to answer and we will do that in the next hour.
- [2] Second, why should you care about something called UIS, anyway? The answer is you shouldn't if you work in total isolation and don't have anything to do with what most of the Agency does. If, however, you--like most of us--have some part in the total information flow from collector to customer and believe--as I do--that there is still room for improvement in how you as a user access, handle, and process the information you deal with, then you have a vital interest in UIS.

A joint paper presented at the October 1982 Meeting of CISI.

- [3] Third, what's a UIS good for? A couple of years ago we went all over the Agency and asked people what they thought they needed to do their job better or make their job easier. This is what UIS is all about and we will be talking much more about that, both in the next hour and in the weeks and months ahead.

~~(FOUO)~~ Let me digress for just a moment so that much of what I say later will make more sense. I happen to believe that the way we usually state our requirements for what we need is largely inadequate. We as users (and we're all users in one way or another) often have some specific end result in mind such as the way we want to see things on a screen, the way traffic should look when we get it, the processing steps needed to handle it, who gets it next, and so on. From talking with analysts in A, B, and C, I am convinced they understand and exploit the use of computers for their work very, very well. In other words, we have some pretty clear ideas about just what it is we do today, what we need to do it, and in many cases, what the hardware and software ought to provide us to let us do more, or do it better. When we try to project our future needs, however, it is often with the mistaken idea that we should be able to specify and build a turnkey solution with the

same degree of certainty--the "big bang" theory of building systems. Instead, we end up with a detailed specification of a changeable, uncertain, future need. We run into trouble because the system development process and the analytic process are very similar. They are both learning experiences: prototyping, testing hypotheses, and feedback are vital. We build upon the results of our experiences both successful and unsuccessful. It really is more of a process than an event.

[redacted] described it well in his talk to CISI last May when he talked about the importance of prototyping and feedback--and the shortcomings of the requirements process--developing TSS software for analysts. [1]

(FOUO) Somehow we have gotten into the practice of specifying requirements in global, abstract, artificial, functional, and sometimes meaningless terms when we attempt to fully define a solution "up front" to a problem we don't fully understand yet. The end result, I think, is that the system designer is often unclear about what he is trying to build and the user, the analyst, the customer, is unclear about what he is getting. The user thinks the screen is going to be formatted one way and the designer does it some other way because the requirement simply says there will be so many protected or unprotected fields of information, certain "functional" capabilities for manipulating the information, and perhaps a performance specification of some sort--all of which has little meaning in the only terms that count--namely satisfying the end user.

(FOUO) Both the customer and the designer have done their best, given the requirements, and yet the result is not satisfactory.

(FOUO) The best recent example of dealing with the right kinds of requirements in the right way is the A21 graphics project.

(FOUO) To overcome the language barrier between analysts and systems designers, more than 1,500 mock-ups were constructed so there could be no doubt about what the analyst expected to see and what the designer expected to produce. There was a solid basis for building the system based on a common understanding of the specific desired end result.

(FOUO) What does this have to do with UIS? We need to do more prototyping. We need to involve the user throughout. We need to be building systems which readily adapt to changing needs--not ignore or refute them--or even worse, require the end user to continually adapt to a rigid system conceived years earlier. UIS is designed to change and adapt to change where it matters most: with the end user--with people. I am interested in the end result of UIS, which we are going to describe, and not in some abstract philosophical concept. I am going to be asking you to consider UIS in terms of your job as an analyst, a programmer, a manager, or whatever. I am going to invite you to offer any suggestions you might have now or later and I hope you will want to work with us as we begin to develop UIS and make it real. I would ask you to think in terms of end results--in the most practical terms that you can of what you really need and how you would like to see it work.

(FOUO) By the end of this century we will have a complex network of people, computers, and communications to do the SIGINT job and virtually everyone will be a part of it in

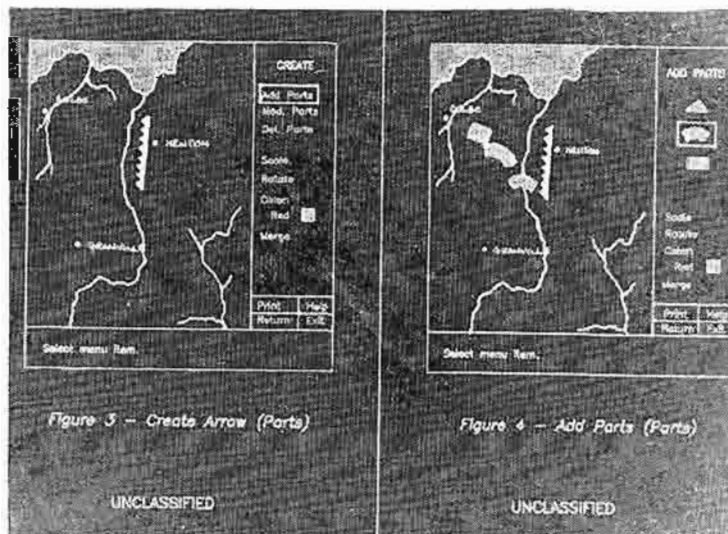

Figure 3 - Create Arrow (Parts)

Figure 4 - Add Parts (Parts)

UNCLASSIFIED

UNCLASSIFIED

some way. UIS is the next vital step in the evolution that began with timesharing many years ago, continued with the development of the PLATFORM network and the GTSS/UNIX Terminal Subsystems, and the now-ubiquitous (almost) user terminal. The end of the century isn't that far off.

~~(FOUO)~~ Having set the stage, I will talk about UIS especially from the user's point of view (to the extent that I can) and  will talk about the UIS architecture itself (how it's glued together) and our plans for an actual prototype beginning this year.

P.L. 86-36

Goals, Definitions and Architecture

~~(FOUO)~~ UIS is the means of bringing closer to the user convenient, affordable, interactive, and personal access to the Agency's computing, communications, and data base resources.

~~(FOUO)~~ The stated "formal" goal of UIS is to enhance user productivity by providing timely delivery of information and immediate access to required data, computing, and human resources.

~~(FOUO)~~ Who is the UIS "user" anyway and what is his job? This model of the SIGINT data flow system contains many functions (except for the "support" functions I mentioned earlier), all of which are performed by what I consider to be potential UIS users.

~~(FOUO)~~ To place the UIS concept in perspective in relation to the flow of data through the Agency, this generalized model of the real-time SIGINT system (used by Mr. George Cotter in a recent CISI briefing) shows, in the horizontal direction, the flow of data from collectors to processors to product data bases to consumers and, in the vertical direction, the interaction of users with the data flow and the processors. NFAS (NSA Forwarding and Access System), the subject of a later briefing, is our networking architecture which is concerned with the horizontal axis of this model; UIS applies to the vertical direction.

~~(FOUO)~~ A blow-up of the right-hand portion of Mr. Cotter's model is a fair representation of the UIS architecture.

~~(FOUO)~~ Simplifying this diagram and putting other labels on the boxes produces an architectural model of UIS.  will treat this in more detail in his portion of the talk.

P.L. 86-36

Technology Issues

~~(FOUO)~~ UIS, in continuing the trend of the past decade to move data and processing power closer to the end user, will take advantage of state-of-the-art technology as it becomes commercially viable.

~~(FOUO)~~ The key to UIS--the personal computer--will soon have greatly increased computing power, internal memory, and disk storage capacity. Other devices included in UIS are graphics computers, word processors, and office automation equipment. (Throughout this talk I will intentionally use the term "personal computer" to include these variations.)

~~(FOUO)~~ Coupling this end-user power with networking and switching technology will place, under the direct control of the end user, the capability for him to control nearly all of his processing and data access requirements.

~~(FOUO)~~ Networking and packet switching technology will allow the user to access data bases and processing on other Agency mainframe computers, to communicate with other users, and in general to expand his horizons beyond his desktop to the entire SIGINT system.

~~(FOUO)~~ UIS host computers will provide a complete set of user services such as access to PLATFORM and PLATFORM resources. Additionally, the UIS host will provide data storage and management facilities, data conversion and reformatting services, mail, file archiving, security, and other support for various communities of users and a variety of general utilities.

~~(FOUO)~~ The resulting "layered" or distributed processing environment made up of personal computers, UIS host computers, and mainframe computers will form the basis for a dramatic change in the way most of us will work.

The Key to UIS

~~(FOUO)~~ The personal computers--or, as they are known in UIS parlance, Terminal Workstations (TWSs)--are the primary elements which will bring about the change from existing methods of working to the UIS environment. Only recently has the cost of personal computers decreased sufficiently to make them an affordable resource for most Agency personnel. Experts predict that the price per terminal will fall to a point within the next five years that a productivity improvement of only 8 to 10 percent will justify the investment of one-third of a person's average annual salary.

Apr 83 \* CRYPTOLOG \* Page 4

~~SECRET~~

~~HANDLE VIA COMINT CHANNELS ONLY~~

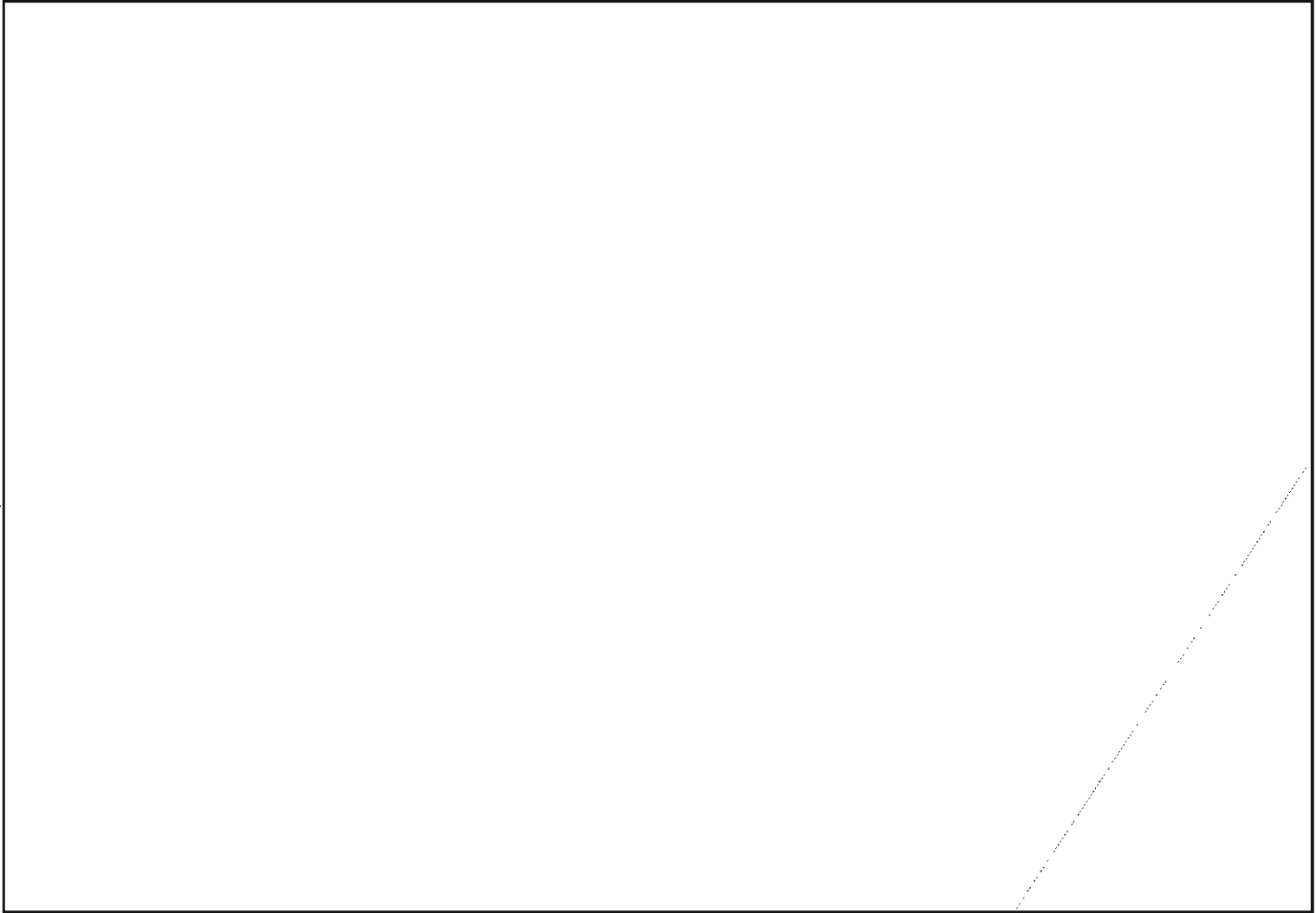

~~SECRET~~

EO 1.4.(c)  
P.L. 86-36

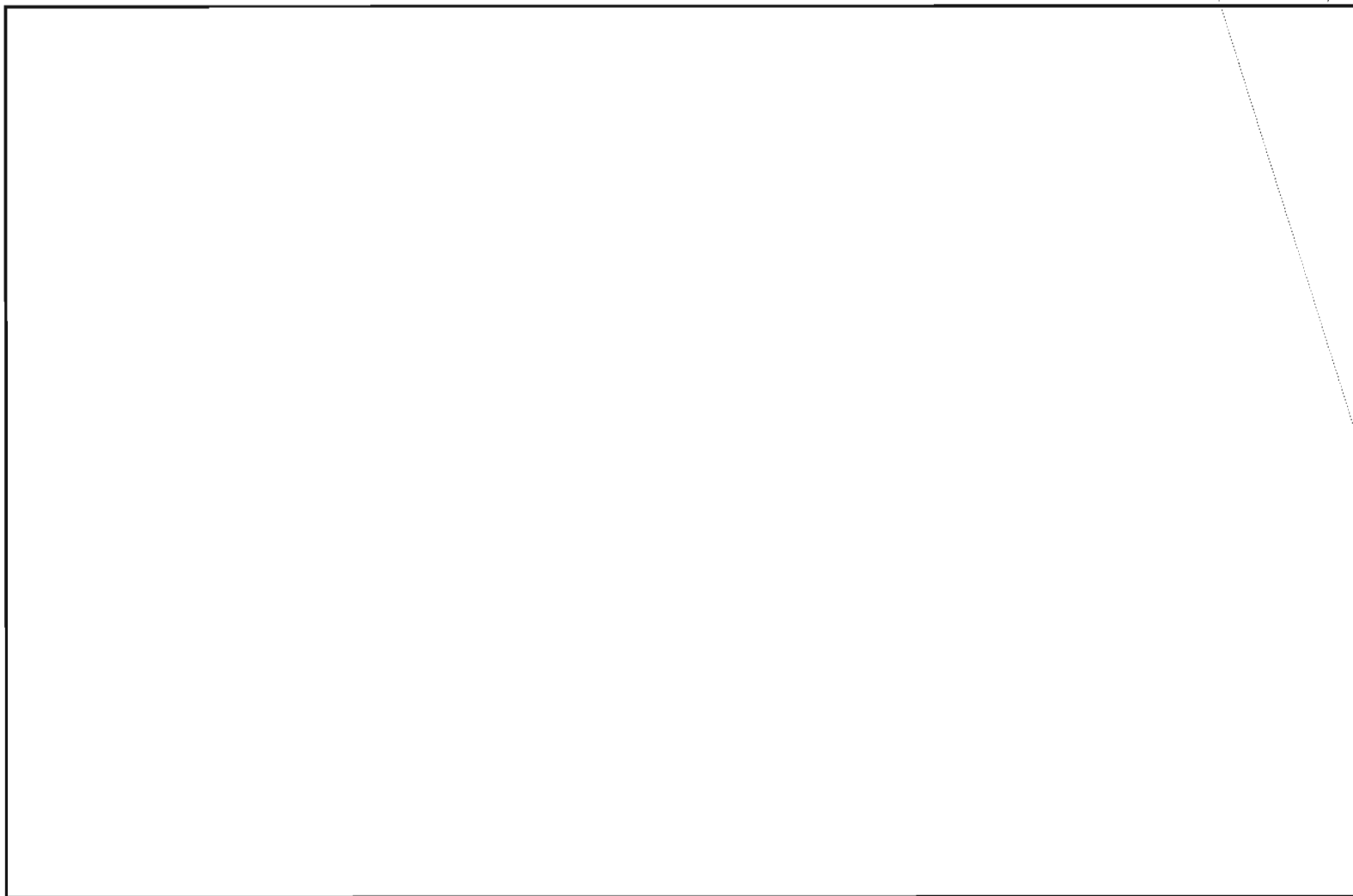

Apr 83 \* CRYPTOLOG \* Page 5

~~SECRET~~

~~HANDLE VIA COMINT CHANNELS ONLY~~

~~SECRET~~

~~Handle via COMINT Channels Only~~

~~SECRET~~

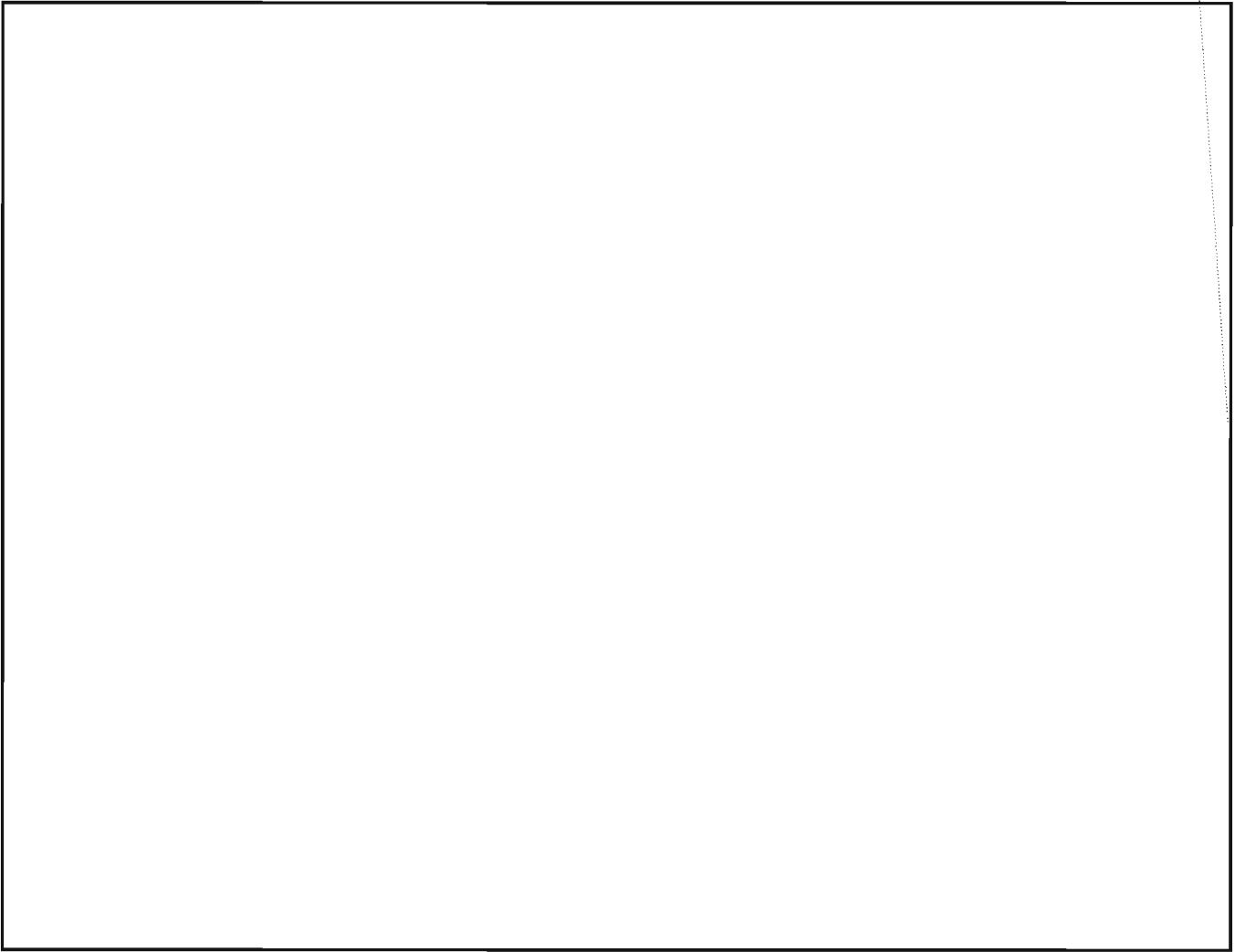

APR 83 \* CRYPTOLOG \* Page 6

~~SECRET~~

~~HANDLE VIA COMINT CHANNELS ONLY~~

~~SECRET~~



Today that's about \$9,000. However, it is the opinion of these same experts that a significant (15-50%) productivity gain can be realized from a large portion of the Agency's workforce as they convert to a UIS environment.

~~(FOUO)~~ Just what is meant by a Terminal Workstation in UIS terms? Briefly, a TWS is a personal computer with sufficient local memory, disk space, display capacity, and communications support to provide the user with local computing power and, when needed, to connect him to a more powerful machine--a UIS host or the PLATFORM network and the Main Computer Complex. The TWS will be running under UNIX or at least a UNIX-compatible multitasking executive. The UNIX user interface, the file structures, the interprocess communication, and the shell environment are all essential elements. Additionally, the TWS will support, at a minimum, the C compiler and the BASIC interpreter. PASCAL may also be desirable as well. The current recomposition for a replacement of the Agency standard terminal (the Delta Data 7000T) is designed to acquire a personal computer of the type just described.

~~(FOUO)~~ Personal computers (although not with the capacity or the compute power described above) have been in use at the Agency and have been experimented with for at least three years as part of a program initiated by Mr. Kermith Speierman to explore this new dimension in computing. During this period much has been accomplished, spearheaded by the P1 organization, primarily in the areas of cryptanalysis and traffic analysis. Most of this work has been designed to determine just how useful a personal computer can be in running programs previously available only on large mainframe computers or to do work done by hand at the analyst's desk. All of this early experimentation was done primarily in a stand-alone mode (Stage I, if you will) although several of the personal computers have been hooked up to Terminal Subsystem (TSS) hosts (PDP-11/70s) and thus were able to access data bases on other systems. Analysts have used this facility to transfer data to the personal computer. This was Stage II in the evolution of the application of personal computers.

~~(FOUO)~~ UIS will lay the basis for development of Stages III and IV. People do not work in isolation. Sharing of files and programs and communicating with each other is necessary. The prototype of the Stage III working environment is being developed in the TSS of today. UIS will build on this work, marry it to the power of the personal computer, and provide a new host with enhanced capabilities. Stage IV will be accomplished when analysts worldwide

through UIS terminal workstations can directly affect (and be directly affected by) the flow of data from the collectors to the product data bases and on to the consumer.

~~(FOUO)~~ Moving increased computing power nearer to the end user will cause a steady, but inevitable and vast, evolution to occur in the way data is stored, processed, and accessed. The nature of the Terminal Workstation is so different from the directly-connected terminals now in use, that we will be forced to rethink our most basic and traditional ways of moving, storing, and manipulating information. I cannot emphasize this point enough! The TWS reduces the dependence of large numbers of users on central processors and central data bases. Data processing and data storage and access can now be scattered in a large number of locations accessible to large numbers of people and processes. The tough challenge that DDT faces in implementing UIS is matched by the equally tough challenge faced by DDO (in particular) of applying the technology to best advantage once implemented. There is already a good deal of work going on in P1, A3, A6, B2, B5, B6, G3, and elsewhere which is leading in this direction.

#### The User's View: A UIS Scenario

~~(FOUO)~~ Several times in this talk, assertions have been made that UIS will cause a change in the way the user works; will cause a change in the way we move, store and manipulate data; and will challenge all of us to derive the maximum benefit from the implemented technology. To dramatize the differences between the system today and the system as it should be under UIS, a scenario describing the way a user might operate under UIS follows. The person described is a composite, if you will, of all the analysts, reporters, transcribers, flow managers, programmers, secretaries, office staffs, and managers who will be users of UIS Terminal Workstations of various kinds. But, within the scenario describing our general analyst's day, will be some of the things you might do.

~~(FOUO)~~ Our UIS TWS user arrives at his desk and powers up his personal computer. The system will ask for his personal ID and password. Once the system is satisfied that the user is who he claims to be, the user will not have to identify himself to any other computer he may wish to connect to during the day; his TWS will pass his verified identity to any other computer requiring it at the time of connection. The other computer needs only to determine that the person requesting access has been granted access permission. Specific file access on another system might require other

security measures that would occur after the connection was granted.

#### MAIN MENU

1. HELP
2. TEXT EDITING
3. TA FUNCTIONS
4. CA FUNCTIONS
5. TRANSCRIBER FUNCTIONS
6. REPORTER FUNCTIONS
7. PROGRAMMING FUNCTIONS
8. RESEARCH FUNCTIONS
9. OFFICE SYSTEM
- .
- .
- .
21. SYSTEM FUNCTIONS

ENTER # OF SERVICE  
& PRESS RETURN KEY: ? (2)

←P0000→ Now that the UIS user has gained access to his personal computer and through it to that portion of the rest of the SIGINT system that he needs access to, he will be presented with a menu tailored to those functions that he routinely performs. At the top of the menu will be a HELP command and at the bottom of the menu will be a selection that will allow him access to the general system commands--the equivalent of a percent sign (%) for those of you familiar with UNIX. Our user will select from this menu some function he wants to start his day. Typically, this would be a review of his personal calendar or a scan of all the messages sent to him by other users or by other computers since he last looked.

←P0000→ Throughout the day he will interact with the rest of the system to send and receive mail and messages, transfer files to and from the MCC (the Main Computer Complex) or local UIS host systems, etc. However, the majority of his day will be spent using the data storage capacity and compute power of his personal computer, largely independent of the MCC.



Apr 83 \* CRYPTOLOG \* Page 8

#### TEXT EDITING MENU

1. HELP
2. MEMORANDUM FORMAT
3. NOTE FORMAT
4. RECORD MESSAGE FORMAT (UMPS)
5. SPECIALIZED FORMATS
6. CREATE A FILE
7. EDIT AN EXISTING FILE
8. VIEW A FILE
9. VIEW A DIRECTORY OF FILES
10. PRINT A FILE
- .
- .
- .
20. RETURN TO MAIN MENU
21. SYSTEM FUNCTIONS

ENTER # OF SERVICE  
& PRESS RETURN KEY: ? (20)

←P0000→ Up to this point most of the functions our user will need are probably common to the vast majority of UIS users. One important function in this category is text processing. Since we all deal with text in some way or other through most of the day, a text-processing capability within the terminal is of prime importance. Wouldn't it be great if the many documents we produce each day (including end product, messages, reports, transcripts, plans, programs, etc., etc.) would have to be typed only one time? And if others could review and/or edit them easily and conveniently without always reducing them to hard copy? Text processing needs to be as readily available as the No. 2 pencil and as flexible as the pocket calculator.

←P0000→ From here on, the functions our UIS user selects from his menu become more specific, reflecting the duties of his job. The power of the personal computer allows us to tailor common, standard, modular functions into individual menus for each TWS user.

#### ANALYSIS MENU

1. HELP
2. SCAN/EDIT TRAFFIC PROCESS
3. EDIT TA LOGS
4. TEXT EDITING
- .
- .
- .
20. RETURN TO MAIN MENU
21. SYSTEM FUNCTIONS

ENTER # OF SERVICE  
& PRESS RETURN KEY: ? (20)

~~(FOUO)~~ He might select from his menu the function that would allow him to scan the traffic that has accumulated for the past 24 hours and edit some of it, discard some of it, or copy some of it for later use as part of a report.

## MAIL MENU

1. HELP
2. SEND MAIL
3. VIEW MAIL RECEIVED
4. TELECONFERENCE
- .
- .
20. RETURN TO MAIN MENU
21. SYSTEM FUNCTIONS

ENTER # OF SERVICE  
& PRESS RETURN KEY:? (20)

~~(FOUO)~~ He might select from his menu the function that would allow him to send an informal message to another analyst halfway around the world or to read messages sent by that analyst to him. Given that time differences are not too great, he might even enter into an interactive conversation with the other analyst.

SPECIALIZED REPORT FORMAT  
MENU

1. HELP
2. RECORD MESSAGE (UMPS) FORMAT
3. USSID ### FORMAT
4. KLIEGLIGHT FORMAT
5. TECHSUM FORMAT
6. PROCUREMENT REQUEST FORMAT
7. PERSONNEL SUMMARY FORMAT
8. LEAVE REQUEST FORMAT
9. TRAINING REQUEST FORMAT
- .
- .
20. RETURN TO MAIN MENU
21. SYSTEM FUNCTIONS

ENTER # OF SERVICE  
& PRESS RETURN KEY:? (20)

~~(FOUO)~~ He might select from his menu the function that would provide templates of any one of the hundreds of formatted reports we produce daily. After filling in the necessary information and correcting any errors, he would transfer it electronically to one or several people for coordination/comment. Getting the commented versions back electronically, he would make necessary changes and transfer

the report to the person authorized to release it. Upon release, the report would be distributed electronically to all designated recipients, people who would read the report and take action or computers that would use the report as an update to some data base.

## PROGRAMMERS MENU

1. HELP
2. C
3. BASIC
4. COMPILE
5. TEXT EDITING
- .
- .
20. RETURN TO MAIN MENU
21. SYSTEM FUNCTIONS

ENTER # OF SERVICE  
& PRESS RETURN KEY:? (20)

~~(FOUO)~~ If our user is a programmer, he might select from his menu the function that would allow him to generate a program or to revise a program which he had entered earlier. He would have the necessary support functions to enable him to design and plan the program, properly format the input, and document the results. Given that the language he used to program was one recognized by the TWS (BASIC, C, PASCAL, etc.), he could ensure that the program was syntactically correct before connecting to the host or main frame for compiling or execution.

## REMOTE ACCESS MENU

1. HELP
2. CONNECT TO SOLIS
3. CONNECT TO ULTRAMARINE
4. CONNECT TO CARILLON
- .
- .
20. RETURN TO MAIN MENU
21. SYSTEM FUNCTIONS

ENTER # OF SERVICE  
& PRESS RETURN KEY:? (20)

~~(FOUO)~~ Our typical user might select from his menu the function that would allow him to conveniently and interactively access several computers where information was stored. Required information could also be brought back to the TWS and used to answer a query, become part of some report, or simply be a working aid of some sort.

OFFICE SYSTEMS MENU

- 1. HELP
- 2. CALENDAR
- 3. MESSAGES/MAIL
- 4. MEMOS
- 5. PHONE BOOK
- 6. TEXT EDITING
- 7. SPELLING CHECK
- 8. NOTES
- 9. ACTION/SUSPENSE FILE
- .
- .
- 20. RETURN TO MAIN MENU
- 21. SYSTEM FUNCTIONS

ENTER # OF SERVICE  
& PRESS RETURN KEY:? (20)

~~(FOUO)~~ A manager might select from his menu the function that would allow him to examine his calendar for the day and a suspense/action file of items that should be completed. A request for any mail (to include administrative messages, personal notes, reports for comment/concurrence, etc.) would bring a list of items to his attention appropriately prioritized by his secretary or staff. His decision-making process is helped throughout the day by selecting from the menu functions that allow him convenient access to data containing technical, budget, planning, personnel, and management information.

~~(FOUO)~~ At any time during the day, if the TWS is powered on, any computer in the SIGINT system could send information directly to the TWS. When received, the user would be notified and he could take appropriate action. This facility could be used to update the user's work queues, to alert the user to the arrival of high interest traffic or mail or an incoming OPSCOMM, or failure of a critical program in the flow. It is a means to get real-time, human interaction into the flow of the SIGINT process. These brief and highly simplified scenarios highlight several advantages that the UIS concept has over today's operation:

- [ ] UIS is capable of being tailored very specifically to each user while, at the same time, taking advantage of general utilities common to all users.
- [ ] UIS does not depend on the 100% availability of the MCC or UIS Host systems for the user to do useful work.
- [ ] UIS Terminal Workstations will provide powerful computer capabilities and data storage facilities conveniently and directly available to the user.

- [ ] UIS will provide convenient access to the rest of the SIGINT system when required.
- [ ] UIS will not only allow the user to affect the system but allow the system to directly affect the user, thus establishing a continuous feedback loop between the user and the system.

Planned Evolution

~~(FOUO)~~ It is not enough to provide an architecture and an operational concept. This briefing and the many papers that have been written (and will be written) are designed to present the UIS concept to a wide audience so that systems designers can begin to incorporate UIS concepts in their designs. But it is not enough to hope that the UIS concept will be implemented through the efforts of many project managers. There is technology that must be developed (or acquired) and demonstrated. The UIS technology and techniques must be demonstrated in an operational prototype and the real challenge of the problems posed by a distributed data processing environment must be solved. T44, with DDT's approval and with considerable help from other organizations throughout the Agency, hopes to introduce a UIS prototype within the coming year where the system designer and the user can collaborate to produce a functioning UIS environment. We have already begun to work with PI analysts and others to see which "real" analytic problems we should be addressing first. If any of you would care to make any suggestions or want to know more about what we are doing, I invite you to get in touch with me. [redacted] will be describing some of our early plans for the prototype in the second half of this briefing.

P.L. 86-36

- 1. [redacted] TSS Revolution, Cryptolog, Sep 1982, pp. 8-12.

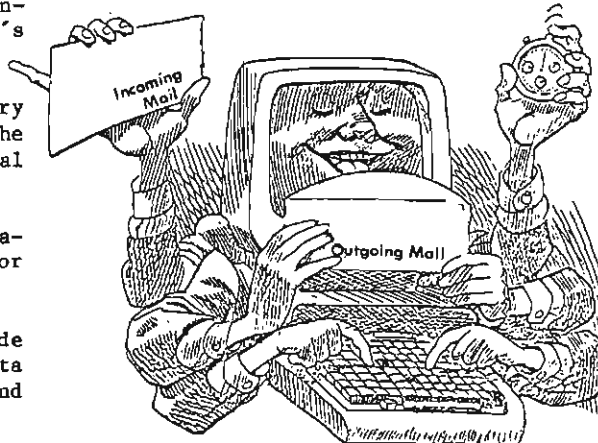

P.L. 86-36

PART TWO: ARCHITECTURE

by [redacted]

(FOUO) Now that Tom has told you what UIS is for and how it has gotten to where it is, I will tell you how it is made up. I intend to cover the Architecture (how it all fits together); the technology which makes it possible at this point in time; the components (some of which already exist) which make up UIS; our approach to making UIS real in all its aspects; and especially the UIS Prototype, which is our initial move in getting UIS where we want it to be.

(FOUO) This is the basic UIS Architecture. It consists of three main levels of components, with interconnection between these levels.

(FOUO) At the outer level (closest to the user) we have the User Component which is where all private data and applications reside. This is the user's private workspace, to be treated rather like a desk, chair, phones, file, and scratchpad would be used today; it will provide as much data storage and computer power as we can afford.

(FOUO) At the intermediate level we have the Community Components, which is where the individual user comes into contact with his fellow workers. It is here that data needed by more than one user is stored (e.g., a calendar which an executive shares with his secretary, or a frequently-used operational data base). In addition to the sharing function it is at this level that support to users, above and beyond that which the User Component can provide, is available (e.g., file archiving, high-quality printers, extended computing power).

(FOUO) At the innermost level are the Global Components, the major computer complexes in the basement. These must be accessible by the user through the other elements of UIS, and we do not envisage that they will change significantly because of UIS.

(FOUO) There are two levels of connectivity, the Community Network, the element which connects the user to his Community Component and to other users, and the Backbone Network which connects all major components. While there is only one (logical) Backbone Network, there are many Community Networks. The function of these components will become clearer later in the briefing.

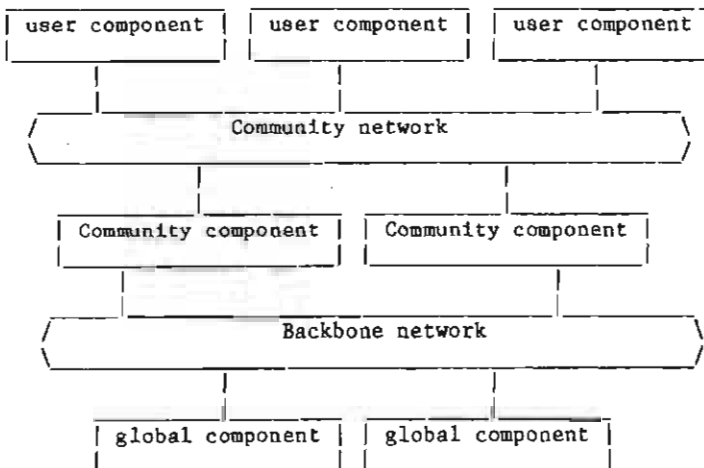

UIS ARCHITECTURE CONCEPT

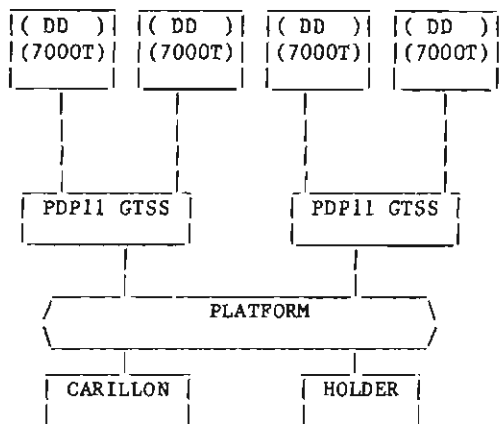

UIS ARCHITECTURE NOW

~~(FOUO)~~ If all this sounds too ethereal, let us look at what we have today and see how closely it corresponds to this architecture. As you can see the Global Components are in place, as is the Backbone Network, in the form of the PLATFORM network. The Community Components are represented by the existing PDP 11-based GTSSs, which are the starting point for the full Community Components but also contain the Community Network and User Component facilities, because these are only point-to-point lines and "dumb" terminals respectively.

~~(FOUO)~~ The next few slides show how we expect to develop from where we are now to where we hope to be at the end of UIS.

~~(FOUO)~~ The first item to be tackled is to replace the "dumb" terminals with Powerful Personal Computers (PPCs) and thus greatly expand the local processing and storage available to each user, literally on his desk. This process has already begun with the use of a variety of PCs in many different organizations within NSA. I'll talk more about the technical characteristics of these devices later but as far as the user is concerned the Powerful Personal Computer, implemented as what we call the Terminal Work Station, is the basis for the User Component. It will provide the user with local, affordable, available, and private computing resources--it is his own machine, with sufficient storage for his private data, processing power (and, of course, software) to satisfy, say, 90% of his computing requirements and, when the Terminal Workstation needs it, access to larger computers, to other data, and to the worldwide network of users.

~~(FOUO)~~ As a starting point, the Terminal Work Station will run the UNIX operating system and so will have available to it many of the applications currently used on the PDP 11 GTSSs--one notable exception being the RAND Editor, which will be replaced by a Word Processing package native to the TWS itself.

~~(FOUO)~~ As a first step towards introducing the concept of a Community we shall reduce the reliance on a single host by means of a simple switching function, implemented either as a digital switch or using some early offerings in Local Networking.

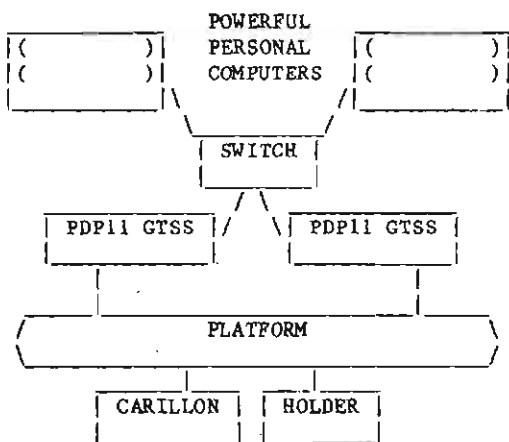

UIS ARCHITECTURE  
THE POWERFUL PERSONAL COMPUTER

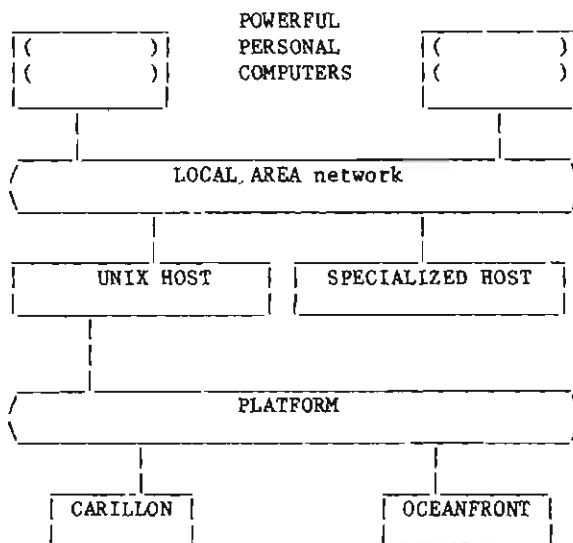

UIS ARCHITECTURE  
COMMUNITY NETWORK AND SUPPORT

~~(FOUO)~~ This extended local power has to be linked to the Community-level components in a much faster and more flexible way than we have at present. This will be achieved by means of the emerging Local Area Networking technology (of which more later). We are looking here for more than mere connectivity; we are looking for some measure of intelligence in making decisions as to which hardware component at the Community level a User Component needs to connect to. (If a user wants to archive a file, it is no good connecting him to the print server!)

~~(FOUO)~~ The development of the Community Component will be somewhat slower, relying initially on the existing TSSs and their look-alike replacements. By supporting UNIX in both the PPCs and the Host, the transition from Host software to Terminal software will be accomplished over a period of time. This will be hastened by the inclusion at the Community level of certain specialized processors, of which the most obvious are the Database Machines as typified by the Britten-Lee IDM-500, with which T3 is currently experimenting.

~~(FOUO)~~ Extending the idea of reducing our dependence on a single host, we shall introduce at this stage the idea of a file server which holds Community files; when a user requires processing and data, he is allocated to any available machine and the file server stages the required data to that machine. One may even wish to consider whether interactive connection between the User and Community levels should be replaced by a transactional protocol. In the long term one can conceive of the Community Component as evolving from a set of General-Purpose Processors to become a collection of specialized processors.

~~(FOUO)~~ A major limitation of the previous phase of the development is the necessity of passing through a general-purpose processor to get to the Global Components. This would be made easier by including a special-purpose machine at the Community level with the job of handling the gateway function from the User to the Global levels. This in itself is a major undertaking.

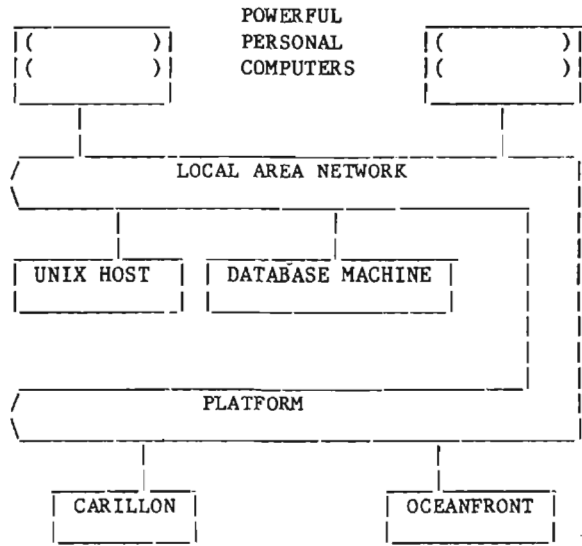

UIS ARCHITECTURE  
THE USER'S DREAM

~~(FOUO)~~ If we continue with this trend, the Community and Backbone Networks merge. It may be, however, that this is more a Utopian dream than an achievable goal, though it must always be our aim to make the network appear to the user to be one cohesive whole rather than a set of mazes to be negotiated only with skilled navigating.

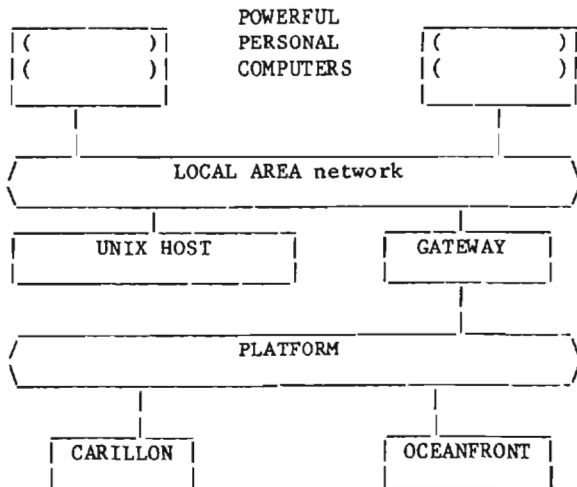

UIS ARCHITECTURE  
ACCESS TO GLOBAL RESOURCES



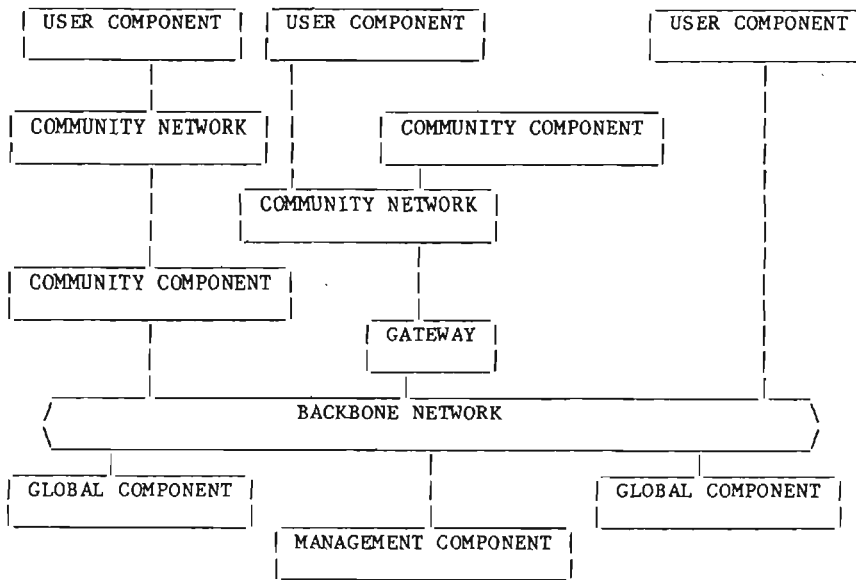

~~(FOUO)~~ Clearly these phases will overlap considerably so what we actually end up with is a configuration more like this one; the elements of the previous slides can still be seen as individual entities however.

~~(FOUO)~~ A new element, one which is vital to UIS but which I won't say much about today (mainly because we haven't defined it very well yet), is the Management component. This is where the system is monitored, controlled, and kept healthy. Although shown here as a

single box it is likely to be a fully distributed function (when we can figure out how to build it).

~~(FOUO)~~ A typical UIS Community will look rather like this (below). As well as the elements described so far there will be specialized User Components supporting Graphics, interfaces to dedicated Office Automation networks, and local print facilities. This is just a redrawing of the earlier conceptual slides with some real names on the components.

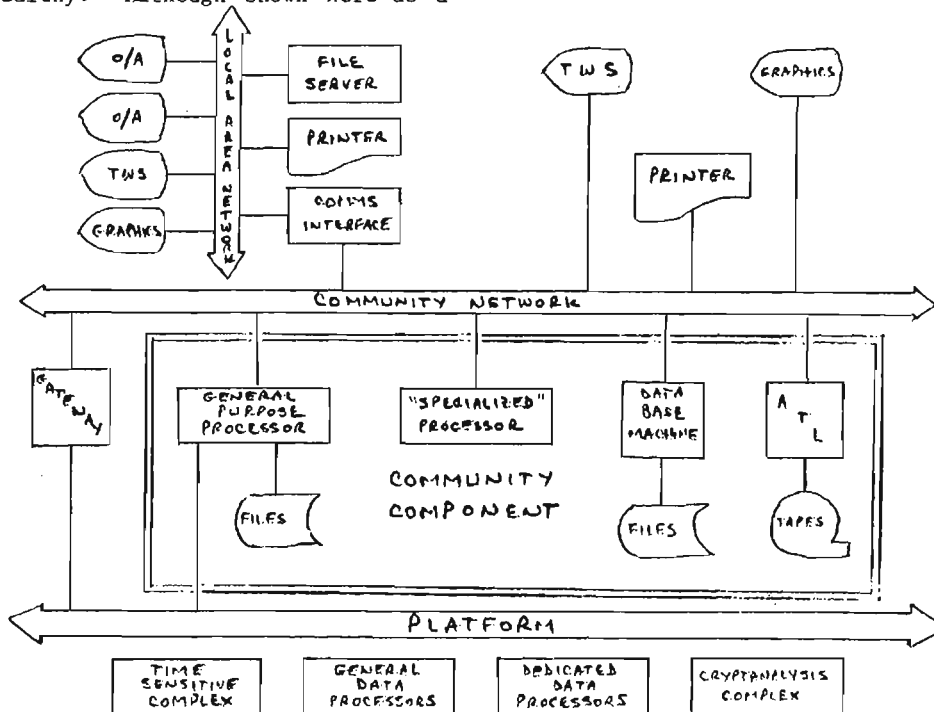



TECHNOLOGY/COMPONENTS

~~(FOUO)~~ Having looked at the architecture, we turn to the question of why now is the right time to be making a big push for the UIS idea. After all, there is nothing particularly revolutionary in the ideas; they develop out of existing systems and the natural course of technological advances.

~~(FOUO)~~ The important thing at this time is that the technology is now becoming available to allow us to move usable processing nearer to the user in a cost-effective manner. This is a continuation of a long transition from central batch processing, through remote access, GTSS systems, and networking to the emerging use of personal computers. The key technologies needed to realize the UIS concept are Powerful Personal Computers and Local Area Networks. Community Support Processors, while not in themselves new technology (they are developing in a steady progression from the existing GTSSs), are essential components of UIS and their form and function will be modified by the increased use of the PPCs and LANs. Global Networking we already have and will need to exploit and expand to support the UIS method of working.

~~(FOUO)~~ Let's now look at some of these technologies in a little more detail.

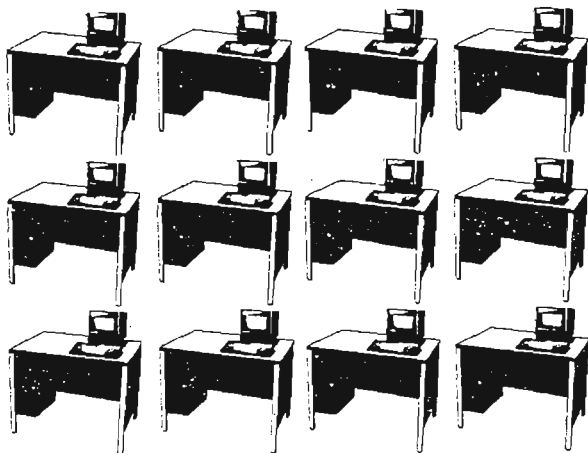

TECHNOLOGY/COMPONENTS  
Powerful Personal Computer

- Keyboard/Screen
- Powerful Microprocessor
- At least 256Kb Memory
- 10 Mb+ Winchester Disc
- Communications Interface/Software
- Tempest
- UNIX
- Word Processor Software
- Data Base Support

~~(FOUO)~~ The PPC which we can now purchase for around \$10,000 satisfies the definition given here. It is no accident that the specifications of the UIS Terminal Workstation and the Agency standard terminal to replace the DD7000, known and loved by so many Agency personnel, are so similar.

~~(FOUO)~~ You will notice that the memory requirements (both main memory and back-up storage) are large--some people say too large; this is a natural (and relatively cheap) response to the information explosion. We have never had enough storage on any computer (and probably never will have) but at least the responsibility for the organization of this storage is totally with the user.

~~(FOUO)~~ TEMPEST is a restrictive but necessary requirement.

~~(FOUO)~~ As we have mentioned earlier, we are looking to a PPC which supports the UNIX operating system or something which looks very much like it. This will give the dual advantages of portability of the current TSS software and of user familiarity.

~~(FOUO)~~ The communications interface, properly supported by vendor software, is another key element allowing the user to access the remainder of his world.

~~(FOUO)~~ We are looking for an extensive amount of vendor-supplied software in addition to the ability to transport UNIX-based software from the GTSSs.

~~(FOUO)~~ A device such as that described here could not have been purchased a year ago.

TECHNOLOGY/COMPONENTS  
Local Area Network

- Hardware is available and cost effective
- Software is developing
- Tempest

~~(FOUO)~~ Local Area Networking technology (needed for the Community Network) is somewhat less mature than PPC technology. It is growing apace and many vendors are pushing their hardware. Clearly, this is the technology we need and will get; equally clear, however, is that we can't buy the software (mainly the implementation of protocols) needed to give us the necessary functionality.

~~(FOUO)~~ To UIS the Community Network has more than just a switching function; it is the means by which the User projects his image to the world. For instance, most current PPCs come with an asynchronous communications interface running at around 9.6 Kb; this makes the PPC look to hosts like a dumb terminal. What we need, however, is to make the PPC look like what it is: a computer with high-speed file transfer and other sophisticated capabilities. The ability to drive data into the TWS without the user having to control the transfer is a key UIS function, needed to support overnight offloading of data from the more centralized processors, for instance. Clearly, this goes well beyond what is currently available in the Local Area Network marketplace, and requires changes in the connection strategy of the PPCs and the Hosts as well as the LAN technology--but it is still part of what a user considers as the network.



TECHNOLOGY/COMPONENTS  
Community Support Processors

- PDP 11/70 now
- Replacement Host
- Support for 100 terminals
- How many PPCs?

~~(FOUO)~~ The existing GTSS has served us well and will continue to do so, as will its immediate successor which is now being competed for. Existing applications will continue to be run but will steadily be replaced by applications in the PPC--these may be copies of the same software in the TSS--and by specialized processors.

~~(FOUO)~~ Current PDP 11/70s support up to 32 directly-connected users; the replacement Host will support perhaps 100. By implementing UIS we hope to extend the support to several hundred, of whom only a small proportion are actually using Community resources at any one time, thereby enabling Communities to be exactly what they need to be--all users who work together--no longer being restricted to the 32 terminal users of each system.

~~(c)~~ Incidentally, you may notice that we haven't explicitly defined what we mean by a Community. This is about the closest we have come. This is not an oversight. We believe that UIS should allow the Users to decide what they want to constitute a Community, which may be as small as an individual office or as big as all analysts



EO 1.4.(c)  
TECHNOLOGY/COMPONENTS 86-36  
Global Networks

- PLATFORM
- Theater Networks
- Global Interconnection

Global Components

- Little or no change

~~(FOUO)~~ Global Networking is already with us, in fact has been for many years, and we see an evolutionary progression towards greater survivability, increased throughput and timeliness, and greater functionality. This is required for reasons other than UIS and will be accomplished through the use of theater networks and a global interconnection of networks.

~~(FOUO)~~ We do not see any major changes to the Global processors in the immediate future, though they will undoubtedly be affected in the long term as we eliminate directly connected user terminals.

THE PROTOTYPE AND BEYOND

~~(FOUO)~~ So where do we start on these grandiose plans?

~~(FOUO)~~ The obvious place is the Terminal Workstation, which is what the user will perceive as the interface to the whole processing system.

~~(FOUO)~~ I have talked about the things we need on the Powerful Personal Computer and Tom talked about the facilities provided to users on the user component. It is the implementation of the User Component on a PPC, as the Terminal Workstation, which is the first real challenge of UIS. The PPC, even with extensive vendor software, is not enough. We have to add specific NSA software; we have to make it attractive and secure to store data on this local device and to manipulate it locally, to make it easier to access other machines (without knowing a litany of FTP commands for instance), and to generally be friendly to the person manipulating the keyboard.

~~(FOUO)~~ It is not until we have done all of these things that we can begin to claim that we have implemented the User Component of UIS.

~~(FOUO)~~ To gain experience in the technology and, more importantly, to be able to demonstrate that the ideas we have presented today make sense, are achievable, and are attractive to the end users, we are building a prototype system in T44.

~~(FOUO)~~ We have already gained some experience by using Xerox 820s, originally purchased as programmable word processors but subsequently adapted by us to support other office functions and communications to PLATFORM. This experience has proven invaluable in enabling us to specify a much more powerful and flexible device for the true prototyping effort.

~~(FOUO)~~ This prototype is a joint venture with

P1 personnel, who also have considerable experience in the use of personal computers. The intent is to bring in up to 12 Powerful Personal Computers and turn them into Terminal Workstations, as described earlier.

~~(FOUO)~~ We have chosen terminals made by WICAT for use in the prototype as they fall within an acceptable price range and are the earliest models to have all, or nearly all, of the features we need.

~~(FOUO)~~ Under the UIS umbrella we shall also be getting experience with Local Area Networking. We are, for instance, working with T15 to improve the operation of the numerous TSSs in the basement by pooling of peripherals. We shall also use this type of technology to connect the WICAT terminals to a number of NASs and TSSs, such as CARONA and STEPSTONE-T03.

~~(FOUO)~~ As we get these components in place and start to use them, we shall undoubtedly run into snags, so we must remain flexible in our approach and try to solve the problems as they arise. (We have already changed our minds at least twice on how to connect the TWS to the Community level and on how many WICATs to buy.)

~~(FOUO)~~ This prototype, which we expect to have operational by August 1983, will be used to demonstrate the functions shown here.

A P P R O A C H

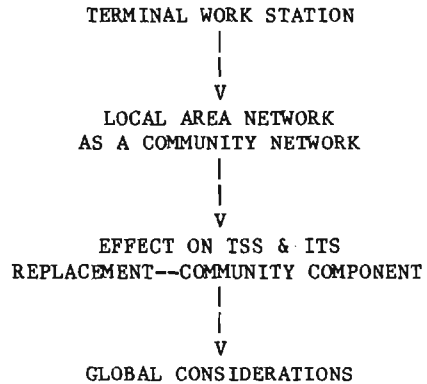

~~(FOUO)~~ Within the WICAT we shall demonstrate Office Automation functions such as Word Processing, memo generation, and calendar and phone directory maintenance; some CA applications taken from existing PCs; and parts of some TA applications taken from the PINSETTER suite.

~~(FOUO)~~ Our means of making the terminal user-friendly is to use a menu-driven approach, with the user prompted for the

minimum amount of information. On our existing Xerox 820s, for instance, we perform transfers to and from CARONA through a NAS and only ask the user for the file names on each system and his CARONA password--rather different from the FTP sequence needed if the user is sitting at a dumb terminal.

~~(FOUO)~~ Networking applications will include electronic mail (messages generated on the local TWS but distributed using the existing software in the TSS) and dissemination of the TA files to the individual analysts.

~~(FOUO)~~ Additionally, the prototype will be used to investigate some of the areas which are less well defined, such as:

- distributed data;
- extension of TWS power;
- new applications;
- use of new technologies;
- management of users; and
- protocol issues.

~~(FOUO)~~ Some of the specific things we have in mind for this further stage are:

- How to use the Britten-Lee IDM 500 Data-Base Machine as a specialized Community Component;
- Alternative User Components, such as the Xerox 860s and Stars under the Office Automation program and the AYDEN CORE Graphics in support of A21 (as a prototype of Jerkin);

~~(FOUO)~~ Most of the other items on this slide are in the nature of a wishlist at present; they will become better defined as we get the things from the previous slide implemented and have more resources to devote to the investigational, rather than demonstrational, aspects of the prototype.

~~(FOUO)~~ Having concentrated firstly on the outermost layer (the TWS), we intend to move steadily inward to implement secondly the Community Network using a full-function Local Area Network, as described earlier. This will greatly improve performance and flexibility over the existing point-to-point connection. The effect on the TSS caused by these developments will be the third area to receive attention--by the time this happens specialized processors will be maturing, applications will be moving out to the TWS, and greater functionality will be available, thereby allowing

a significant step forward to be made. Finally we shall see if there are any effects on the Global Network and the Global Components.

~~(FOUO)~~ In parallel with this mainstream development we shall be studying the problems of access, security, accounting, control, and other management implications of an increasingly distributed environment.

#### SUMMARY

~~(FOUO)~~ In closing, I should like to return to Tom's original questions.

#### What is UIS?

~~(FOUO)~~ Well, I hope we have explained the Concepts, the Architecture, and the Components sufficiently to answer this question.

#### Why should you care?

~~(FOUO)~~ You should care because this is the way the Agency will be doing its business by the end of the century, and if you don't want to get left behind you should make sure you have your UIS personal computer with its considerable local computing power and practically limitless communications ability.

#### What is UIS good for?

~~(FOUO)~~ Our answer is that it is good for everything which involves a person, and one or more of: data, computing, or communications. If you didn't recognize anything familiar in the scenarios Tom went through, you are probably in the wrong meeting. If you recognized more than a little of what you need to do your job, then please watch as we try to answer the question more accurately and in more detail by gaining experience with real users and with their reactions to the prototype. If you can see immediate, useful, and powerful applications to your work area, please give us a call.



*Cumulative Index*  
*Part Two: Titles (U)*



P.L. 86-36

EO 1.4.(c)  
P.L. 86-36

Abdul and His 40 Tanks; Aug 75; Mason F.O.  
About the NSA SIGINT Summary; May 76; [redacted]  
Accentuate the Negative; Apr 78; [redacted]  
Agency Summer Language Study; Dec 78; Buckley D.  
AG-22/IATS: A View From the Bridge; Jun 77; [redacted]  
AIT; Apr 80; [redacted]  
a/k/a Sam; Dec 78; Meyer W.P. EO 1.4.(c)  
Al Balloni, Editor; Sep 77; A.J.S. P.L. 86-36  
Al Balloni, Editor; Jan 79; A.J.S.  
All I Ever Wanted To Know About DES; Aug 82; [redacted]  
All The Alligators Aren't On Sport Shirts; Jan 82;  
Amateur Spread Spectrum; Jun 82; [redacted]  
[redacted] Nov 77; [redacted]  
Analysts of NSA, Arise!; Jan 80; [redacted]  
And-a You Betta Have Moti-vaysh!; Oct 78; [redacted]  
Another Cipher by ...; Sep 76; [redacted]  
Another Controversial Book on Artificial Intelligence; May 77; [redacted]  
Another Last Word on IATS; Sep 77; [redacted] P.A.  
Another Source; Oct 79; [redacted]  
Another Word on AG-22/IATS; Oct 76; [redacted] M.A.  
Answer to Can You Make Out the Name!; Apr 75; [redacted]  
Answer to Three Holes; Mar 78;  
Answer to 'Vexing ... Problem'; Nov 76; Mason F.O.  
Answer: An Old Problem; Oct 82; [redacted]

P.L. 86-36

The following cumulative index of CRYPTOLOG (Vols. I through IX, 1974-1982) is in three parts, and is being published in three successive issues, by author, by title, and by keyword. Items in multiple issues (February-March 1975, for example) are indicated by the first month (i.e., by Feb 75).

Apollo-Soyuz Test Project; Dec 76; [redacted] J.E.  
The Apostrophe: Some Thought's; Nov 74;  
An Approach to Callsign Analysis; Dec 74; Jackson W.J.  
Are We Wasting Linguistic Time?; May 75; Irwin M.R.  
As I Was Saying Two Years Ago ...; Jun 78; Pattie M.T.  
ATA Letter to President Carter; Apr 78; Tinsley R.L.  
Attention Authors and Publicity Chairmen; Mar 82;  
Attention Military Traffic Analysts; Mar 79;  
An August Baudy; Aug 79; [redacted]  
[redacted] Sep 77; Pratt D.L.  
Automation of a TA Process; Oct 75; Murphy T.

P.L. 86-36



P.L. 86-36

Back to Square One!; Oct 78; [redacted]  
Backing into Language Acquisition; Nov 77; [redacted]  
The Baltic Encoders; Jun 79; Reiskis A. EO 1.4.(c)  
Basic Patterns of [redacted] Codes and Ciphers; Feb 75; [redacted] P.L. 86-36  
Between The Lines of Your Performance... P.L. 86-36  
Appraisal; Jan 80; [redacted]  
The Bible and the Washington Monument; Sep 76; Snow D.  
[redacted] Mar 77; [redacted] Jul 77;  
Bookbreakers Forum; Jun 78; [redacted] P.L. 86-36  
Bookbreakers Forum; Apr 79;  
Bookbreakers Forum On Machine Aids; Apr 82;  
[redacted] Jul 77; Buck S.R.  
The Bucky Balance; Jul 78; [redacted]  
Bust Answer; May 82; [redacted]  
But It Looks Like the Real Thing; Dec 76; [redacted]  
But Life Is Supposed To Be Hard; Mar 82; [redacted] J.  
But, Mr. Boak, Did You Ever Try To Get Rid of One in a Hurry?; Apr 79; D.H.W.  
But Why Do We Do It?; Jan 78; [redacted]  
By-Lines Don't Cost--They Pay!; Feb 78; Mollick J.J.

EO 1.4.(c)  
P.L. 86-36



CAA News: What Ever Happened to the CAA?; Jul 77; [redacted]  
 CAA News: What Are They Up to Anyway?; Aug 77; [redacted]  
 CAA News: Whom?; Sep 77; [redacted]  
 CAA News; Oct 77; [redacted]  
 CAA News; Nov 77; [redacted]  
 CAA Message and News; Dec 77; [redacted]  
 CAA News; Jan 78; W.E.S.  
 CAA News; Feb 78; W.E.S.  
 CAA News; Mar 78; W.E.S.  
 CAA News; Apr 78; W.E.S.  
 CAA News; May 78; W.E.S.  
 CAA News; Jun 78; W.E.S.  
 CAA News; Jul 78; W.E.S.  
 CAA News; Sep 78; W.E.S.  
 CAA News; Oct 78; W.E.S.  
 CAA News; Nov 78; W.E.S.  
 CAA News; Jun 79;  
 CAA News; May 79;  
 CAA News; Aug 79; [redacted]  
 CAA News: Conference on Communications Analysis; Oct 79; [redacted]

P.L. 86-36

[redacted] Mar 77; [redacted]

D.A.  
 Calling All SRAs! -- SRA Symposium; Aug 74; [redacted]  
 P.L. 86-36

Callsigns and WARC-79; May 78; [redacted]  
 CAMINO News; Feb 75; [redacted]  
 The Case for COMINT Readers; Jan 75; [redacted]

H.G.  
 Cast a Double Shadow: The Trojan Horse of SIGINT; Nov 78; [redacted]  
 Celtic Languages Today; Jun 78; [redacted]  
 Central Research and The Paper Blob; Nov 82; [redacted]

The Changing Face of NSA; Jan 78; 'Anon.'  
 Chapenko, Shapenko: What Difference Does It Make?; May 79; [redacted]  
 Character Building in the People's Republic of China; Oct 74; [redacted]  
 Check Your Morse Front-End Alignment; Nov 76; 'Anon.'

[redacted] Dec 82; [redacted]  
 Choose Yel; May 77; [redacted]  
 CIRC: An Intelligence Data Base; Jan 80; [redacted]

CISI News; Mar 79;  
 CISI News: Spring Conference; May 79;  
 CLA News; Mar 78;  
 CLA News; Sep 78;  
 CLA News; Oct 79;  
 CLA News: Sydney Jaffe Award; Jan 80;  
 CLA News: Russian Institute; Feb 79;  
 Clarity, Thy Name is Qualifier; Nov 76; Mollick J.J.

Classic Cables; Apr 79;  
 Classic Cables; Mar 79;  
 Classic Cables; May 79;  
 Classic Cables; Apr 81;

Classification Corner; Jul 77; [redacted]  
 Classification Corner: XGDS-2; Sep 77; [redacted]

Classification Corner: A Bigger Picture; Oct 77; [redacted]

Classification Corner: Who Said?; Oct 77; [redacted]

CMI News; Jan 79;  
 CMI News; Aug 79; [redacted]  
 Codeword or COMINT Channels?; May 75; [redacted]

R.  
 Collection-Support TA is Not for Everyone; Feb 78; [redacted]

Coming Home; Jan 80; [redacted] EO 1.4.(c)  
 COMINT Analysis of [redacted] Sep 78; L. 86-36

The COMINT Chain 'Gang'; Feb 79; [redacted]  
 COMINT, COMSEC, and Hilbert's Tenth; Jan 78; [redacted]

COMINT in the Russian Navy, WWII; May 76; [redacted]

A Comm Change at Ramasan Station; Apr 75; [redacted]

Comments on AG-22/IATS; Jun 76; [redacted]  
 Comments on AG-22/IATS; Jun 76; [redacted]  
 Comments on AG-22/IATS; Jun 76; [redacted]  
 Comments on AG-22/IATS; Jun 76; [redacted]  
 Comments on AG-22/IATS; Jun 76; [redacted]  
 Comments on AG-22/IATS; Jun 76; [redacted]  
 Comments on AG-22/IATS; Jun 76; [redacted]  
 Comments on AG-22/IATS; Jun 76; [redacted]

A Comparison of NSA and ATA Certification Standards; Mar 76; [redacted]

Computer-Aided Transcription [redacted] EO 1.4.(c)  
 [redacted] Apr 76; [redacted] P.L. 86-36

Computer Network Resources In C5; Aug 75; [redacted]  
 Computer Operating System Vulnerabilities; Mar 79; [redacted]

Computers In The ELINT and Telemetry Business; Jun 76; [redacted] P.L. 86-36

Computers, Comms, and Low-Grade Ciphers: The [redacted] EO 1.4.(c)  
 [redacted] Oct 75; [redacted] P.L. 86-36

A Computer Scratch Pad at Home or at Work?; Jun 78; [redacted]

Some Reflections On The Reality of Computer Security; Jun 82; Hanyok R.J.

COMSEC Challenges; Nov 82; [redacted]

COMSEC Familiarization: Do You Need It?; Jun 75;

COMSEC/SIGINT Relations; Apr 79; Boak D.G.  
 +Conoces Bien la Geografia?; Apr 78; [redacted]

Human Factors Corner: Consumer vs. Computer: A Review; Mar 82; [redacted]

Contemplating Computing; Apr 77; [redacted]  
 Continuing Professionalization; Oct 78; [redacted]

Contributions Solicited; Sep 74;  
 Conversation With a Micrographics Pioneer; Dec 77; [redacted]

Conversation with a Bookbreaker; May 76; 'Anon.'

The Costs of Muddling Through; Nov 82; Gould R.E.

Coverterms; Apr 75; Filby V.R.

E.L. 86-36

Cryptanalysis and Code Recovery; Sep 74; Mountjoy M.  
 Cryptic Crossword; Nov 81; [redacted]  
 Cryptic Crossword; Mar 82; [redacted]  
 AFCEA 82 and ICC-82: New Crypto Devices; Aug 82; [redacted]  
 CRYPTOLOG Index for 1974; Dec 74;  
 CRYPTOLOG Index for 1974; Jan 75;  
 CRYPTOLOG Index for 1974-1975; Dec 75;  
 CRYPTOLOG Index for 1977; Dec 77;  
 CRYPTOLOG Index for 1978; Dec 78;  
 CRYPTOLOG A Letter of Introduction; Aug 74; Wolff R.E.  
 CRYPTOLOG Numbering; May 82;



The Danang Processing Center; Oct 75; [redacted]  
 A.  
 Data and Definitions: Calling Things by Their Rightful Names; Nov 74; [redacted]  
 Data Field Naming/Coding Conventions at NSA; Jan 82; [redacted]  
 Data Flow--Challenge of the 1980s; Apr 80; Phillips C.J.  
 Data Security and Human Error; Oct 78; [redacted]  
 J.M.  
 Data Standards Center; Nov 78; Pattie M.T.  
 Data Standards Without Tears; Feb 79; [redacted]  
 P.Q.  
 Data Standards Without Tears: A Comment; Mar 79; [redacted]  
 Data Standards Without Teeth; Jun 79; [redacted]  
 P.Q.  
 Dating Game; Jul 77; Williams D.H.  
 Development and Correlation of Indicators; Dec 82; [redacted]  
 DESKPAD: A Programmers' Tool; Nov 75; [redacted]  
 H.  
 The Devil's Dictionary; Feb 75;  
 DIA Videocassette Program; Apr 81;  
 DIALOG Available at NSA; Aug 77;  
 A Dialogue Between Ms. User and Dr. Analysis; Nov 78; [redacted]  
 Diego Garcia? What? Where? Why?; Nov 74; [redacted]  
 G.A.  
 Director's Memorandum: 'MAROON SHIELD Guidance'; Nov 77; Inman B.R.  
 The Doctor Is In(capable of Diagnosing); Sep 77; Chauvenet L.R.  
 Does Anybody Here Remember PURPLE?; Dec 82; [redacted]  
 A Donkey in Your WHAT?; Mar 78; [redacted]  
 The Do Xa Pads; Oct 75; Wiley E.



Early Days in NSA Computing; Aug 77; [redacted]  
 L.R.  
 An Early NSA Proposal for Satellite Remoting; Jan 78; Horn J.E., Nolte W.M.

Economic Intelligence: Problems and Prospects; Oct 81; [redacted]  
 Emitter Identification Techniques; May 79; [redacted]  
 Equipment Maintenance on ABNER; Jun 78; EO 1.4.(c)  
 [redacted] P.L. 86-36  
 [redacted] Dec 77; [redacted]  
 Establishment of CSI Newsletter; Dec 75;  
 An Evaluation of a Scientific Chinese Machine Translation; Jun 76; [redacted]  
 Even a 5-year-old Child ...; Oct 74; Tetrault E.W.  
 Executive Order 11652; Jan 77; 'Leiner'  
 Exercise Support; Dec 81; [redacted]  
 EXPERT; Jul 79; [redacted]  
 Expletives Deleted: Glossing Over a Glossary; Feb 76; [redacted]  
 Expletives Deleted?; Aug 77; Salemme A.J.



Fairbanks on English; Mar 79; Fairbanks S.  
 The Faithful Echo--The Role of the State Department Interpreter; Feb 75; [redacted]  
 Fear of Testing, and What To Do About It; Apr 79; [redacted]  
 Feeding the Germans Misinformation (Book Review); Oct 78; Pilby P.W.  
 A Few Thoughts on the NSA Linguist; Mar 77; 'Anon.'  
 First Lady of Navy Cryptology; Feb 78; [redacted]  
 R.P.  
 A Fix for the Language Problem?; Aug 75; [redacted]  
 Flag-Waving Programmer; Dec 74; John G.  
 Flash! 115th SRI Located!; Apr 77; Salemme A.J.  
 Football and Cryptology; Jan 76; [redacted]  
 Foreign Publications Procurement Program; Sep 76; Link L.  
 Formatting PL/1 Source Code; Nov 78; [redacted]  
 K.J.  
 The French(fried) Connection: Gino the Genie; Dec 76; [redacted]  
 The [redacted] System; Feb 76; [redacted]  
 Full or Broad Spectrum Lighting; May 82; [redacted]  
 The Future of Cryptanalysis; May 78; Lutwiniak W.  
 Futuristic Reporting; Nov 81; [redacted]



P.L. 86-36

EO 1.4.(c)  
 P.L. 86-36

Gary's Colors; Sep 74; Garofalo C.A.  
 Gayler - AAAS, 1982; Feb 82; [redacted]  
 Gears of the Mouth; Jul 79; Lasley D.  
 Geographic Trivia; Apr 80;  
 Glossaries versus Dictionaries: Which Should It Be?; Feb 75; Curin J.

Golden Oldie: The Management Survey of the Philharmonic; Aug 74;  
 Golden Oldie: King Eusyb and Queen Deodi; Sep 74; [redacted]  
 Golden Oldie: An Unofficial Glossary of Weasel Words; Oct 74;  
 Golden Oldie: Establishment of Molecule Superseries; Feb 75;  
 Golden Oldie: SIMP Tables; Jun 75; [redacted]  
 Golden Oldie: Blue Russian; Nov 75; [redacted] J.F.  
 Golden Oldie: Hidden Losses in COMINT Production; Apr 76; Gould R.E.  
 Golden Oldie: The Things They Say; Nov 76; Miller D.E.  
 Golden Oldie: Analyzation of Data; Oct 77; [redacted]  
 Golden Oldie: Unidentified Unit at Unknown Location; Jun 78;  
 Golden Oldie: On First Opening Kenney's 'Statistics'; Jan 79; Mountjoy M.  
 Golden Oldie: Reporting Message Volumes; Jun 82; [redacted]  
 Golden Oldie: Simplicity in Color; Feb 82; [redacted]  
 Golden Oldie: Tracks in the Sands of Time; Apr 82; Mason F.O.  
 Golden Oldie: The Reality of Communications Changes; Oct 82; [redacted]  
 The [redacted] Collection System; Jun 76; [redacted] T.  
 Grading The Russian PQE; Apr 81; [redacted]  
 Graphic Analysis of Linear Recursive Sequences; Dec 75; [redacted]  
 Graphic Names; Dec 76; [redacted]  
 The Great Soviet Shipbuilding Mystery; Dec 75; Williams D.H.  
 A Guide to Central Information, C5; Apr 75;  
 Guidesmanship--or How to Write Technical Manuals Without Actually Giving Anything Away; Nov 74; [redacted]  
 The Gulf of Tonkin Incident; Feb 75; [redacted] W.D.



EO 1.4.(c)  
P.L. 86-36

The Hand Is Not Quicker Than the Eye; Mar 78; [redacted]  
 Has It Ever Been Translated Before?; Jul 78; [redacted]  
 Help Wanted; Apr 80; [redacted]  
 Henry Cement and other Phantoms of the Operations); Jan 79; [redacted]  
 HF - The Rebirth; Jan 82; [redacted]  
 The Hierarchical Clustering of Cryptanalytic Data; Aug 76; [redacted]  
 A Historian Looks at SIGINT; Mar 82; Filby V.R.  
 A History Lesson; May 82; [redacted]  
 Hoopay for PMDs!; May 75; [redacted]  
 How Are Your Stamina?; Jun 79; Fairbanks S.  
 How Do Adults Learn Language?; Apr 76; [redacted]

How Do We Know It's True?; Feb 76; Filby V.R.  
 How Do You Spell Peking?; Dec 78; [redacted]  
 How do You Tell These Two Clowns Apart?; Jan 79;  
 How Many African Countries Can You Spot?; Nov 77; [redacted] EO 1.4.(c)  
 [redacted] Dec 77; Rosenbluh H.G. 86-36  
 How Things Have Changed!; Jun 76; [redacted]  
 How to Create A User-Unfriendly System; Nov 81; [redacted]  
 How to Improve Your Promotion Potential; Jan 81; [redacted]  
 How to Make a Railroad Disappear; Nov 76; [redacted]  
 How Clean Does a Data Base Need to Be?; Jan 75; [redacted]  
 Human Factors: Responsible Documentation; Jun 82; [redacted]  
 Human Factors and Systems Design: An Estranged Relationship?; Jun 77; [redacted]  
 Human Factors and the Use of Microfiche Readers at NSA; Oct 77; Snow D.  
 Human Factors Newsletter; Jan 79;  
 Human Factors Corner: Information System; Jan 82; [redacted]  
 Human Factors Corner: Some Advice to Users of Unfriendly System; Feb 82; [redacted]  
 Human Factors Corner: But What Do I Do With My Papers?; Feb 82; [redacted]  
 Human Factors Corner: Data Gathering, How Do We Spend Our Day?; May 82; [redacted]  
 Human Factors Corner: Video Display Terminals and Vision of Workers; Aug 82; [redacted]  
 Human Factors Corner: Text Editors; Oct 82; [redacted]  
 Human Factors Corner: How Do People Organize Cooperative Work?; Nov 82; [redacted]  
 Hypnosis and Self-Hypnosis in Language Learning; May 76; Buckley D.



[redacted] Dec 78; [redacted] EO 1.4.(c)  
 I Remember SPELLMAN; Jul 78; Salemme A.J. P.L. 86-36  
 The 'Ice Age' and International Security; Apr 77; [redacted]  
 An Idea for an Article; Mar 78; Miller D.E. P.L. 86-36  
 In Praise of SOLITS; Nov 75; Grant L.G.  
 In Defense of The Indefensible: Notes on the Russian PQE; Feb 79; Tetrault E.W.  
 In Pursuit of: Faster Horses, Younger Women, Older Whiskey and More Money; Dec 81; [redacted] D.L.  
 [redacted] Nov 75; [redacted]  
 W.L.  
 The NSA Information Desk: 'No Comment'; May 82; [redacted] EO 1.4.(c)  
 Initiatives in SIGINT Reporting; Aug 76; [redacted] 86-36  
 Integrated Analysts for Asia; Aug 76; [redacted] W.D.



[redacted] Mar 78; [redacted]  
 IRONHORSE: A Tactical SIGINT System; Oct 75;  
 [redacted]  
 Is A Translator a Professional?; Jul 78;  
 [redacted]  
 Is There a Doctor in the House?; Sep 77;  
 [redacted]  
 Is There Life After Certification?; Sep 76;  
 [redacted]  
 It's Party Time!; Jan 79; [redacted]

# J

The Joys and Frustrations of Plural-Dropping;  
 Jan 78; A.J.S.  
 The Joys of UNIX; May 78; [redacted]  
 JPRS Language Reference Aids; Sep 77;  
 [redacted]

# K

KITTIWAKE; Jan 81; [redacted]  
 Know Your Geography; Oct 78; [redacted]  
 Know Your Geography; Feb 79; [redacted]  
 Knowledge Resource Management at NSA; Sep 77;  
 [redacted]  
 KRYPTOS News; Dec 82 [redacted]  
 KRYPTOS: A New Society; Feb 82; [redacted]  
 KI: SCA Field Management and Evaluation; Oct  
 77; [redacted]

# L

P16 Language and Cryptologic Library; Apr 80;  
 [redacted]  
 The Language of Baseball in Everyday Talk; Aug  
 74; [redacted], Santiago-Ortiz R.A.  
 Language Career Panel: Clarification of Nov 78  
 Item; Feb 79;  
 Language in the News; Sep 74; [redacted]  
 Language in the News; Dec 74; [redacted]  
 Language in the News; Apr 75; Tetrault E.W.  
 Language in the News; Aug 75;  
 Language in the News: Language Rule; Apr 76;  
 Language in the News; Aug 76;  
 Language in the News; Sep 76;  
 Language Lessons Learned: A Personal Memoir;  
 Oct 75; [redacted]  
 1976 Language Meetings and Conferences; Mar  
 76;  
 Language Processing Forum; Nov 77; [redacted]  
 [redacted]  
 Language Proficiency Certificates for Military  
 Personnel; Aug 79; [redacted]  
 Language Skill File; Oct 76; [redacted]  
 [redacted]  
 The Last Word on IATS?; Apr 77; Phillips C.J.  
 Leadership: A Personal Philosophy; Oct 82;  
 [redacted]

Learned Organizations--1974 CLA Essay Contest,  
 1974 CMI Essay Contest; CISI Prizes and  
 Honors, Spring 74; Aug 74;  
 Learned Organizations--CISI Forms Special  
 Interest Group on Human Factors; Dec 74;  
 [redacted]  
 Learned Organizations--IAI News, CISI News;  
 CLA is Ten Years Old!; CMI News; Jan 75;  
 Learned Organizations--CLA News; IAI News; May  
 75;  
 Learned Organizations--CLA News; CMI News; Jul  
 75;  
 Learned Organizations--CLA Essay Contest; CAA  
 News; Dec 75;  
 Learned Organizations--1976 CLA Essay Contest;  
 1976 CMI Essay Contest; Sep 76;  
 Lenin and State Prizes: Now You See Them, Now  
 You Don't!; Jan 76; [redacted]  
 Leo in October; Jan 76; Murphy A.I.  
 Let Me Repeat--And Make Myself Perfectly  
 Clear; Aug 77; Jenks P.  
 Let's Give the Linguists a Bigger Piece of the  
 Pie!; Dec 76; [redacted]  
 Let's Not Forget Our Cryptologic Mission; Feb  
 79; Gurin J.  
 Let's Not Lose Our TA Skills; Mar 79; [redacted]  
 G.  
 Letter From Canada; Nov 76; [redacted]  
 Letter From the Publisher; Jan 79; Lutwiniak  
 W.  
 Letter: [redacted] Article; Oct 74; [redacted]  
 Letter: [redacted] Article; Dec 74; 'Anon.'  
 Letter: Citizens of World Puzzle; Feb 75; [redacted]  
 G.P.  
 Letter: Exinterne Articles; Feb 75; Tetrault  
 E.W.  
 Letter: Exinterne Articles; Apr 75; [redacted]  
 Letter: Professionalization of Bookbreakers;  
 Apr 75; [redacted]  
 Letter: [redacted] Article; May 75; [redacted]  
 Letter: [redacted] Letter; May 75; [redacted]  
 Letter: [redacted] Letter; May 75; [redacted]  
 Letter: [redacted] Letter; Jun 75; 'Anon.'  
 Letter: Bookbreakers; Professionalization of  
 Country Specialists; Jun 75; [redacted]  
 Letter: [redacted] Article; Jun 75; [redacted]  
 Letter: Typewriter Keyboard; Oct 75;  
 Letter: Proud and Bitter Memories Article; Mar  
 76; [redacted]  
 Letter: Proud and Bitter Memories Article; Mar  
 76; O'Neill K.  
 Letter: What Are We About? Article; Apr 76;  
 [redacted]  
 Letter: Comments on [redacted] Letter on What  
 Are We About?; Apr 76; [redacted]  
 Article: [redacted] Article; Jun 76; Murphy A.I.  
 Letter: IRONHORSE Article; Oct 76; [redacted]  
 Letter: [redacted] Article; Oct 76; [redacted]  
 Letter: Cumulative Index; Nov 76; Bostick C.W.  
 Letter: 'Firebrand' Letter on [redacted] Article;  
 Jan 77; [redacted]  
 Letter: [redacted] Article; Jan 77; Kenny  
 M.M.  
 Letter: Mason Article; Jan 77; [redacted]

Letter: Use of Term 'Compartmented'; Jan 77; [redacted]  
 Letter: [redacted] Interview; Mar 77; [redacted]  
 H.L.  
 Letter: [redacted] Article; Mar 77; Buckley D.  
 Letter: C-LINERS Article; Mar 77; 'Appalled'  
 Letter: Keyword Spotting; Mar 77; Gurin J.  
 Letter: [redacted] Article; Apr 77; [redacted]  
 Letter: [redacted] Article; Apr 77; [redacted]  
 Letter: Buckley Letter; Apr 77; Tetrault E.W.  
 Letter: Mason Article; Apr 77; Boucher M.J.  
 Letter: Mason Article; Apr 77; [redacted]  
 Letter: Mason Article; Apr 77; McGrillies J.R.  
 Letter: Buckley Letter; Jun 77; [redacted]  
 Letter: [redacted] Article; Jun 77; [redacted]  
 Letter: Mason Article; Jun 77; [redacted]  
 Letter: [redacted] Article; Jul 77; [redacted]  
 Letter: [redacted] Article; Jul 77; [redacted]  
 Letter: [redacted] Article; Jul 77; [redacted]  
 Letter: [redacted] Article; Aug 77; 'Weeson'  
 Letter: [redacted] Letter; Sep 77; Buckley D.  
 Letter: AG-22 Page Print; Oct 77; 'Reader'  
 Letter: [redacted] Article; Nov 77; Snyder S.S.  
 Letter: Salemme Article; Nov 77; [redacted]  
 Letter: Salemme Article; Nov 77; [redacted]  
 Letter: [redacted] Article; Dec 77; [redacted]  
 Letter: [redacted] Article; Jan 78; [redacted]  
 Letter: [redacted] Article; Mar 78; [redacted]  
 K.E.  
 Letter: [redacted] Article; Apr 78; 'Fenwatcher'  
 Letter: [redacted] Article; Jun 78; Gilbertson  
 E.A.  
 Letter: [redacted] Article; Jul 78; Gurin J.  
 Letter: [redacted] Article; Jul 78; [redacted]  
 Letter: Gilbertson Letter; Sep 78; [redacted]  
 Letter: Pattie Article; Sep 78; Buckley D.  
 Letter: Salemme Article; Sep 78; Williams D.H.  
 Letter: NSA-Croatia; Oct 78; [redacted]  
 Letter: NSA-Croatia; Oct 78; Filby V.R.  
 Letter: [redacted] Article; Oct 78; Pattie M.T.  
 Letter: Appraisal System; Nov 78; 'Anon.'  
 Letter: Appraisal System; Nov 78; [redacted]  
 Letter: [redacted] Article; Nov 78; [redacted]  
 Letter: Ask Art; Apr 79; 'Sue'  
 Letter: Library Changes; Jun 79; [redacted]  
 Letter: Library Changes; Jun 79; [redacted]  
 Letter: 'Sixth Language'; Jun 79; [redacted]  
 P.A.  
 Letter: [redacted] Article; Jun 79; Bjorklund K.  
 Letter: Bjorklund Letter (Jun 79); Jul 79; [redacted]  
 Letter: Bjorklund Letter (Jun 79); Jul 79; [redacted]  
 Letter: Buckley D.  
 Letter: [redacted] Article (Apr 79); Jul 79; [redacted]  
 Letter: Buckley a [redacted] (Jul 79); Aug 79; [redacted]  
 Letter: Data Standards; Mar 79; [redacted]  
 Letter: Grant Article (Dec 78); Feb 79; Pattie  
 M.T.  
 Letter: Gurin Article (Feb 79); Apr 79; [redacted]  
 Letter: [redacted] Article (Dec 78); Feb 79; [redacted]  
 Bostick C.W.  
 Letter: Linguatrivia; Jul 79; [redacted]

Letter: [redacted] Article (Aug 79); Oct 79; Taylor  
 D.L.  
 Letter: Screening Radiation; Aug 79; [redacted]  
 W.E.  
 Letter: [redacted] Letter (Aug 79); Aug 79; [redacted]  
 Letter: [redacted] Article; Jan 82; Chauvenet  
 L.R.  
 Letter: Stairwell Society Article; Jan 82; [redacted]  
 Letter: Cryptanalysis Article; Jan 82; [redacted]  
 A.  
 Letter: UNIX Article; Feb 82; [redacted]  
 Letter: Strangest Bust of the Month; Mar 82; [redacted]  
 Letter: The Literary Bends Article; Mar 82; [redacted]  
 Murphy A.I.  
 Letter: A Toy Problem; Mar 82; Tiren D.J.  
 Letter: Plaintext; May 82; [redacted]  
 Letter: [redacted] Article; May 82; [redacted]  
 Letter: Shell Game Article; May 82; [redacted]  
 Letter: Editorial Comment; Jun 82; [redacted]  
 P.A.  
 Letter: Personal Computer Article; Jun 82; [redacted]  
 Letter: Shell Game Article; Jun 82; [redacted]  
 P.A.  
 Letter: Shell Game Article; Jun 82; [redacted]  
 J.W.  
 Letter: Kudos; Sep 82; [redacted]  
 Letter: Shell Game Article; Nov 82; [redacted]  
 LIME-A, OHIO; LEEM-A, Paru; Apr 80; Salemme  
 A.J.  
 A Linguist Looks at the Tube; Mar 78; Johnson  
 R.S.  
 Linguists From The Melting Pot; Dec 75; Gould  
 R.E.  
 Linguists -- You Have an Expert to Call!; Oct  
 75; [redacted]  
 Linguists -- We Need An 'Experts Yellow  
 Pages'; Aug 75; [redacted]  
 Linguist Machine; Aug 82; [redacted]  
 Linguistics and the Code Reconstructor; Nov  
 78; Buck S.H.  
 LIP; Jan 80; [redacted]  
 The Literary Bends; Jan 82; Murphy A.I.  
 Literature Search On-Line; Feb 79; [redacted]  
 A Little PEP Talk; Apr 78; [redacted]  
 A Little TA Problem; Nov 77; [redacted]  
 A Long Hard Look at the Intern Program--  
 Program Philosophy; Recruitment (Part One);  
 Sep 74; 'Exinterne'  
 A Long Hard Look at the Intern Program--  
 Selection and Orientation (Part Two); Oct 74;  
 'Exinterne'  
 A Long Hard Look at the Intern Program--  
 Motivation and Morale (Part Three); Nov 74;  
 'Exinterne'  
 A Long Hard Look at the Intern Program--What  
 Happens to the Graduate? (Part Four); Dec 74;  
 'Exinterne'  
 Looking at Mr. [redacted] Apr 78; [redacted]

EO 1.4.(c)

P.L. 86 36

Apr 83 \* CRYPTOLOG \* Page 24

P.L. 86-36

P.L. 86-36



EO 1.4.(c)  
P.L. 86-36

Machine Course for Linguists; Apr 75; Tetrault E.W.  
Machine Intelligence--Promise or Delusion?; Jul 75; [redacted]  
Machine-Produced Aids for the Linguist, Part I; Sep 76; Salemme A.J.  
Machine-Produced Aids for the Linguist, Part II; Oct 76; Salemme A.J.  
Partial Machine Translation: Final Report; Apr 82; [redacted]  
Maps in Mind--A Photoessay; Dec 74; [redacted]  
The Marquis and the Medium; Jun 76; Dawson R.  
Match Them Up!; Jul 77; [redacted]  
A Matter of Style; Sep 78; [redacted]  
Memorable Memos; Aug 79;  
Meteorburst Communications; Mar 82; [redacted]  
A Method for Measuring Negative Intelligence; Oct 78; [redacted]  
The Micro Revolution: Arthur Young Study Comment; May 82; [redacted]  
Middle-Age Spread; Apr 81; [redacted]  
NSA/CSS Military Linguist Program; Jan 80;  
Minnie's Mini; Jun 78; Kenny M.M.  
The Mission of the Signals Processing Requirements Panel; Oct 74; [redacted]  
More about More about the NSA SIGINT Summary; Jun 77; Boucher M.J.  
More about the NSA SIGINT Summary; Mar 77; [redacted]  
More B.S. (Before Spellman); Oct 78; [redacted] C.H.  
More Beans; Feb 78; Filby V.R.  
More Comments on the AG-22/IATS; Sep 76; [redacted] B.  
More Fairbanks on English; Apr 79; Fairbanks S.  
More Fairbanks On English; May 79; Fairbanks S.  
More Free Goodies; Sep 82; [redacted]  
More Than Words Can Say; May 79; Gurin J.  
More Thoughts on 'Questionable' SIGINT; Oct 76; [redacted]  
More on Squaring the Page (A Crypto-TA Function); Jun 75; Mason F.O.  
[redacted] Oct 78; [redacted]  
Mum's Still the Word! ('The ULTRA Secret'); Dec 75; [redacted]  
Musings About the AG-22/IATS; Mar 76; Phillips C.J.

NCS Offers Course-Equivalency Tests; Nov 75;  
NCS Offers Course-Equivalency Tests, Clarification; Apr 76;  
NCS Summer Language Program; Oct 79; P.L. 86-36  
Never Again!; Jun 78; Gurin J.  
Never on My Watch; Nov 78; [redacted]  
[redacted] Jan 78;  
New Directions for the U.S. Intelligence Community; Aug 77; Gaddy D.W.  
The New Traffic Analysis Glossary; Aug 74;  
New Trends in the Teaching of Cryptanalysis; Nov 74; [redacted]  
The New Collection Criteria; Dec 74; [redacted]  
There's a New World Coming - Are You Ready?; Jan 80; [redacted]  
News from NCS--Agency Resumes Hiring of LICs; NCS Offers Course in 'SIGINT Appreciation'; Oct 74;  
Nice Busman's Holiday for One NSA Employee; Aug 74; Dudley B.  
1972-1973: A Vietnam Odyssey; Oct 75; P.L. 86-36  
[redacted]  
No, Winnie, You've Got It Upside Down Too!; Feb 78; A.J.S. EO 1.4.(c)  
[redacted] Sep 78; [redacted]  
Normandy: 1944; Sep 82; [redacted]  
Note on FRANCOPHONEGLOS; Aug 76;  
Notes on Translation from the Chinese; Jun 76; [redacted]  
NSA Cryptologic Collection; Aug 76;  
NSA in Vietnam: Proud and Bitter Memories; Oct 75; [redacted]  
NSA-Croatic No. 1; Oct 75; A.J.S.  
NSA-Croatic No. 2; Jan 76; A.J.S.  
NSA-Croatic No. 3; Apr 76; A.J.S. P.L. 86-36  
NSA-Croatic No. 4; Jun 76; A.J.S.  
NSA-Croatic No. 5; Oct 76; A.J.S.  
NSA-Croatic No. 6; Jan 77; A.J.S.  
NSA-Croatic No. 7; Apr 77; Chauvenet L.R.  
NSA-Croatic No. 8; Jul 77; A.J.S.  
NSA-Croatic No. 9; Sep 77; Williams D.H.  
NSA-Croatic No. 10; Nov 77; A.J.S.  
NSA-Croatic No. 11; Jan 78; Williams D.H.  
NSA-Croatic No. 12; Mar 78; A.J.S.  
NSA-Croatic No. 13; Apr 78; Williams D.H.  
NSA-Croatic No. 14; May 78; 'Sardonyx'  
NSA-Croatic No. 15; Jun 78; A.J.S.  
NSA-Croatic No. 16; Jul 78; Williams D.H.  
NSA-Croatic No. 17; Sep 78; A.J.S.  
NSA-Croatic No. 18; Oct 78; Williams D.H.  
NSA-Croatic No. 19; Nov 78; Williams D.H.  
NSA-Croatic No. 20; Dec 78; Williams D.H.  
NSA-Croatic No. 21; Jan 79; Williams D.H.  
NSA-Croatic No. 22; Feb 79; D.H.W.  
NSA-Croatic No. 23; Mar 79; Salemme A.J.  
NSA-Croatic No. 24; Apr 79; D.H.W.  
NSA-Croatic No. 25; May 79; D.H.W.  
NSA-Croatic No. 26; Jun 79; D.H.W.  
NSA-Croatic No. 27; Jul 79; D.H.W.  
NSA-Croatic No. 28; Aug 79; D.H.W.  
NSA-Croatic No. 29; Oct 79; D.H.W.  
NSA-Croatic No. 30; Jan 80; D.H.W.  
NSA-Croatic No. 31; Apr 80; D.H.W.  
NSA-Croatic No. 32; Jan 81; D.H.W.

EO 1.4.(c)  
P.L. 86-36



The Navajo Code Talkers; Jun 75;  
Native Scripting of Languages; Feb 82;  
[redacted]  
Naval Readiness: A Basis for Comparison; Jul 79; [redacted]  
NCS-CLA Symposium; Jan 81;

P.L. 86-36

NSA-Croctic No. 33; Apr 81; D.H.W.  
 NSA-Croctic No. 35; Oct 81; D.H.W.  
 NSA-Croctic No. 36; Dec 81; D.H.W.  
 NSA-Croctic No. 37; Jan 82; D.H.W.  
 NSA-Croctic No. 38; Feb 82; D.H.W.  
 NSA-Croctic No. 39; Apr 82; D.H.W.  
 NSA-Croctic No. 40; May 82; D.H.W.  
 NSA-Croctic No. 41; Jun 82; D.H.W.  
 NSA-Croctic No. 42; Aug 82; D.H.W.  
 NSA-Croctic No. 43; Oct 82; D.H.W.  
 NSA-Croctic No. 44; Nov 82; D.H.W.  
 NSA-Croctic No. 45; Dec 82; Dawson R.  
 NSA Promotion Boards: How They Work; Aug 79;  
 [redacted]  
 NSA's System for Grading Translations; Aug 76;  
 [redacted]

EO 1.4.(c)

EO 1.4.(d)

P.L. 86-36

P.L. 86-36



An Objective Approach to Scoring Translations;  
 Mar 76; [redacted]  
 Objective Satisfaction Score: Collection  
 Performance; Nov 77; [redacted]  
 An October Overlap; Oct 74; [redacted]  
 Answer to An October Overlap; Nov 74; [redacted]  
 J.E.

Odds and Ends; Jun 82; [redacted] EO 1.4.(c)  
 OH, KI; Apr 80; [redacted] P.L. 86-36  
 Is There An Old Crow In Your Future?; May 82;  
 [redacted]

The Old [redacted] Section; Dec 74; [redacted]  
 Old Phone Books Never Die; Mar 82; Nolte W.M.  
 An Old Problem; Aug 82; [redacted]  
 Old Russian Manuscript: Ciphers; Jun 77;  
 [redacted]

An Old Timer Is One Who; Nov 82; [redacted]  
 On Being Truthful; Apr 76; Gaddy D.W.  
 On Coming of Age at NSA: Confessions of an  
 Ex-Linguist; Aug 79; [redacted]  
 Going On-Line With Information Aids; Dec 82;  
 Curia J.

One Day in Danang; Apr 76; [redacted]  
 One Chance in Three--But It Worked; Oct 75;  
 Gerhard W.  
 OPELINT Is Alive and Well In B Group; Nov 81;  
 [redacted]

Oral Reporting: A New Challenge for NSA; Apr  
 75; [redacted]

Overheard in the Burnbag Line; Oct 78;  
 Overheard While Standing in the Burnbag Line;  
 Apr 82; [redacted]

An Overview of Project [redacted] Mar 77;  
 [redacted]



Partners in the Exciting Future of SIGINT; Oct  
 77; Rosenblum H.E.  
 Passwords; Dec 82; [redacted]  
 The Internal Performance Evaluation: Friend or  
 Foe?; Feb 82; [redacted]

P.L. 86-36

The Perils of Being a State Department Inter-  
 preter; Oct 77;  
 A Personal Comment on Winterbotham's 'The  
 ULTRA Secret'; Dec 75; Tiltman J.H.  
 Personal Computer Application; Apr 82;  
 [redacted]  
 A Personal Computer: A Current Cryptanalysis  
 Support Tool; Mar 82; [redacted]  
 A Personal Footnote; Jun 82; [redacted]  
 Plain English; May 77; [redacted]  
 PLATFORM: How Did You Say That Works?; Dec 81;  
 [redacted]

The Poet's Corner; Apr 81;  
 The Polyhedral War; May 77; [redacted]  
 Diesso M.  
 Postscript to 'Dating Game'; Aug 77;  
 [redacted]

The PPC Is Coming!; Nov 81; [redacted]  
 [redacted] Jun 78; [redacted]  
 The Prebendary and the Prophet; Feb 70; Dawson  
 R.

Prizewinners in Three Holes; Apr 78;  
 Processing [redacted]  
 Communications; Aug 75; [redacted]  
 Professionalizing in Computer Systems; Jun 75;  
 [redacted]

Progress-1: [redacted]  
 Sep 78; [redacted]  
 Project CARRIAGE: Worldwide HPDF Modernization  
 Plan; Sep 74; Webster J.B.  
 Project HELIPAD: An Epitaph; May 79; [redacted]  
 M.L.

Project SYMBIOSIS; Jun 75; 'Anon.' P.L. 86-36  
 Project UTENSIL: The DDO Data  
 Dictionary/Directory; May 78; [redacted]  
 A Proposal for Calendar Reform; Dec 74; Leahy  
 F.T.

A Proposed Cure for the 'Performance  
 Syndrome'; Mar 78; [redacted]  
 A Proposed Cure for the Time-in-Grade  
 Syndrome; Nov 77; [redacted]  
 P.S.; Feb 79; [redacted]  
 Psyching the Code Clerk; [redacted]

[redacted] Apr 75; Callimahos L.D.  
 To Pull a 'Ponyal'; Mar 76; [redacted]  
 Punctuation: More Than Meets The Eye; Aug 79;  
 [redacted]

Purity of the Russian Language--Slavophiles  
 vs. Westernizers; Nov 74; [redacted]

Pursuit of the [redacted] Mar 79; [redacted]  
 E.L.

Puzzle: Stinky Pinky; Aug 74; P.L. 86-36

Puzzle: Telephone Directory; Aug 74; EO 1.4.(c)

Puzzle: [redacted] Oct 74;  
 Puzzle: Secret Messages, 'Military Cryptanalytics'; Dec 74; P.L. 86-36

Puzzle: Citizens of the World; Dec 74;

Puzzle: Crossed Codewords; Jan 75; [redacted]  
 Puzzle: Can You Make Out the Name?; Feb 75;  
 [redacted]

Puzzle: How Many Words in 'CRYPTOLOG'; May 75;

Puzzle: [redacted] Jun  
 75; [redacted]

Puzzle: CRY-PTO-LOGrolling; Aug 75; EO 1.4.(c)

P.L. 86-36

Puzzle: Match Them Up!; Jul 77; [redacted]  
 Puzzle: Three Holes; Feb 78; [redacted]  
 Puzzle: Who and Whom?; Oct 78; [redacted]



Questions In Search of a PQE; Dec 82; [redacted]



EO 1.4.(c)  
 P.L. 86-36

[redacted] Jun 79; [redacted]

M.R.  
 RAPIDTRAN: [redacted]

[redacted] Jul 75; [redacted]

Readers' Survey; Mar 79; D.H.W.

Reduction Ratios in Micrographica; Oct 78;

Snow D.

Reflections and Recommendations; Jan 79; Filby

V.R.

Reflections on a Translator's Conference; Nov

74; [redacted]

Remedial Software Engineering; Apr 78; [redacted]

J.F.

I Remember; Aug 82; [redacted]

Replacement of the GUPPY Library; Feb 75;

[redacted]

Re-psyching the Code Clerk; Jul 75; [redacted]

Research in Speech Perception (Dr. Ruth Day);

Aug 76; Tetrault E.W.

The Return to HF; Jan 79; [redacted]

Review of 'Guide to Russian Technical

Translation' by Salemme; Feb 75; [redacted]

A.J.

Review: In The Name of Efficiency; Dec 81;

[redacted]

Review: The American Magic; Apr 82; [redacted]

Review: What Do You Think?; Nov 81; [redacted]

M.E.

Revised Technical SIGINT Manual in

Preparation; Mar 77; Filby V.R.

Right-to-Left Text Sorts Are Not Impossible;

Aug 74; [redacted]

The Roads Around Us; Oct 79; Chauvenet L.R.

The Role of the Electronic Warfare Advisory

Element (EWAE) of NSA; Jun 75; [redacted]

Rules For The Camel Corps; Mar 82; [redacted]

C.

Run This Through Your Transcription Machine;

May 79; [redacted]

Russian Handbook of Spoken Usage, Vol 3; Jul

79;



Say What You Mean; Nov 81; Gaddy D.W.

Scraps from the Editor's Desk; May 76; Salemme

A.J.

Second Sighting; Jan 79; 'Donym'

Not Secret Anymore; Oct 82; [redacted]

Secrets of the Altars--The Moustier

Cryptograms; Sep 74; [redacted]

Self-Paced Instruction: The Future is Now!;

Aug 74; [redacted]

Semantic Voids: Don't Shoot the Translator;

Sep 76; [redacted]

Seminar on Translation Problems; Jul 79;

Senior Military Cryptologic Supervisors

Course; Feb 78; [redacted]

Shell Game; Apr 82; [redacted]

Shell Game; Aug 82; [redacted]

Shell Game: Counter; Dec 82; W.E.S.

Shell Game: AJSQUE; Dec 82; [redacted]

Shell Game: PWB WHEN; Dec 82; [redacted]

Looong Shell; Jun 82; [redacted]

The [redacted] Exercise: A Case Study in

Special Research Analysis; Oct 74; Filby V.R.

Shootout at the SIGINT Corral; Jul 79; [redacted]

P.S.

A Short Directory of Career Panels; Aug 74; 4.(c)

[redacted] Dec 78; P.L. 86-36

SIGINT Exploitation, 1990; Apr 78; [redacted]

SIGINT In The 80s: Two Views; Jan 81;

Rich R.E., Lutwiniak W.

Russian SIGINT and Electronic Warfare; Oct 76;

[redacted] P.L. 86-36

The SIGINT Users' Handbook or: What's an

ISHTAR?; Jan 75; Oliver D.B.

SIGINT Welcomes INKSTAND; Jun 77; [redacted]

SIGINT: 1990, Part One; Sep 82; [redacted]

SIGINT: 1990, Part Two; Oct 82; [redacted]

SIGINT: 1990, Part Three; Nov 82; [redacted]

Sign Language; Jun 79;

A Simple Cipher Story; May 76; Meyer W.P.

[redacted] Oct 79; 1.4.(c)

Sleep Well: Your SDO Is On Duty; Dec 81; P.L. 86-36

Sawyer E.L.

63 Days--The Soviets in Space; Jan 76; [redacted]

J.

A Small Problem; Nov 78; [redacted]

Snowballs On The Roof; Oct 79; Filby V.R.

Software - AAAS, 1982; Feb 82; [redacted]

SOLIS: A Vehicle in Search of an Engine; Jan

79; [redacted]

Some Background on the C/T Merger; Mar 78;

Smith F.

Some Ideas about Mechanized Language Working

Aids; Oct 76; [redacted]

Some Principles of Cover and Deception; May

76; [redacted]

Some Things Never Change; Jan 81;

Some Thoughts on Lexicography; Sep 74; Buck

S.H.

Some Thoughts on the Russian PQE; Apr 77;

Clark G.L.

Some Tips on Getting Promoted; Dec 78; [redacted]

V.C.

A Somewhat Larger Problem; Apr 79; [redacted]

W.E.

Source Protection: Our Agency's Insurance

Policy; Jul 79; [redacted]

EO 1.4.(c)  
P.L. 86-36

P.L. 86-36

Soviet COMINT and the Civil War; Sep 78; [redacted]  
[redacted] Apr 80; [redacted]  
The Soviet General Staff; Jul 78; [redacted]  
[redacted] Feb 78;  
A Soviet View of NSA; May 76; [redacted]  
Speaking of Logging ...; Sep 77; [redacted]  
A Spot by Any Other Name; Aug 74; Filby V.R.  
The Stairwell Society; Oct 81; [redacted]  
[redacted] Feb 78;  
The Story of MOSES; Jun 79; [redacted]  
A Story With a Moral; May 77; [redacted]  
System Acquisition Document Review; Jan 80;  
[redacted]

Traffic Analysis: Specialty Without Portfolio;  
Apr 81; [redacted]  
A Traffic Analyst Looks at Computers; Apr 80;  
[redacted]  
Traffic Analysis of the Future; Jun 79;  
[redacted]  
Transcriber-Analyst Relations; May 79; Miller  
D.E. P.L. 86-36  
The Transcription Skill: Concepts and Teaching  
Methodologies; Jul 77; [redacted]  
Translator In Your Pocket; Jan 81; [redacted]  
Transliteration or Cyrillic?; Jun 76; [redacted]  
G.  
Tribute to the Guru; Sep 77; 'Class '32'  
True Base: Two Tales; May 82; [redacted]  
TSS Revolution; Sep 82; [redacted]  
Twenty Years of Transposition; Aug 75; [redacted]  
J.E.  
Typewriter Random -- A New Look; Aug 75;  
[redacted]  
The 2000-Year-Old Transcriber; Oct 79;  
[redacted]  
[redacted] and a Little Bit of Luck; Feb 79;  
Williams D.H.

P.L. 86-36



Towards Better System Development; Mar 82;  
[redacted]  
T Establishes Human Resource Development  
Panel; Sep 78;  
T-Vision: The Reference Analyst's Medium of  
the Future; Jan 79; [redacted]  
TA, Handmaiden of CA; May 75; Mason F.O.  
TA Implications of FCC Proposal; May 78;  
[redacted]  
Tactical Language Exploitation: A Lesson  
Learned?; Oct 75; [redacted]  
Teacher Learns a Lesson; Nov 76; [redacted]  
Teaching Computer Science To Linguists; Jun  
79; [redacted]  
Technical Support Catalogs; Oct 81; [redacted]  
K.J.  
A Brief Treatise on Five Laws of Telephonic  
Communications; Mar 82; Nolte W.M.  
Telephone Problem Here; Apr 78; [redacted]  
Tell Me I'm Just a Sinobibliophile; Jul 78;  
[redacted]  
Telling It Like It Is; Aug 77; Santiago-Ortiz  
R.A.  
TEXTA: What Is It? Where Is It Going?; Dec 81;  
[redacted]  
TEXTA 'Word Seek'; Nov 76; [redacted]  
TDB: The TEXTA Data Base; Aug 74; Jackson W.J.  
The [redacted] Seminar Program; Sep 77; [redacted]  
W.L.  
Thanks for the Attaboy!; Jan 78; [redacted]  
Third Party Relationships; Apr 81; [redacted]  
[redacted] Sep 78; [redacted]  
TIDE: A Brief History; Dec 81; [redacted]  
A Time for Change; Feb 82; [redacted]  
TIPS is Still Alive and Well; Sep 76;  
[redacted]  
Too Many Carbles; Jul 75; [redacted]  
Tool Languages; Jul 77; Murphy J.D.  
Toujours La Politesse (Japanese); Nov 76; Buck  
S.H.  
To Whom It May Concern; Dec 78; Grant L.G.

EO 1.4.(c)  
P.L. 86-36



[redacted] Jun 78; [redacted]  
L.S.  
Uncle-a Sam Wantsa You!; May 78; [redacted]  
The 1981 URSI XX General Assembly; Dec 81;  
[redacted]  
The Uses of Elegant English; Nov 76; [redacted]  
J.R. P.L. 86-36  
The Uses of ELINT; Apr 75; [redacted]  
[redacted] Mar 82; [redacted]  
Universes, Galaxies, Stars, Bars, and Other  
Concepts; May 77; Phillips C.J.  
UNNA [redacted] Jan 75; [redacted]  
The Unseen Go-Between; Feb 78; Gurin J.  
[redacted] Oct 77; [redacted]

EO 1.4.(c)



P.L. 86-36

A Vexing Agency-Wide Problem; Oct 76; Mason  
F.O.  
Vich Iss R-r-right?; Jun 77; A.J.S.  
Video Encryption: A Report From EASCON 81; Jan  
82; [redacted]  
A View of the Central Computer Complex in the  
Late 1970s and Early 1980s; Mar 77; Phillips  
C.J.  
A VIP Tour through the Attic of NSOC; Dec 78;  
[redacted]  
VORD is a Better Idea; Mar 79; [redacted]  
The Voynich Manuscript-Third Theory; Aug 75;  
Miller D.E.  
The Voynich Manuscript Revisited; Apr 76;  
[redacted]  
[redacted] Oct 75; [redacted]

EO 1.4.(c)  
P.L. 86-36

EO 1.4.(c)  
P.L. 86-36

# W

A Wail, A Complaint, and a Melange; Feb 82; Snyder S.S.  
 Want to Play with a Pickfair Square?; Aug 77;  
 The Warsaw Pact [redacted] Jul 73; [redacted]  
 Waveguide Analysis; May 76; [redacted]  
 Weapon That Helped Defeat Nazis (Winterbotham's 'The ULTRA Secret'); Dec 75; Filby P.W.  
 Wedding Bells and That Old Gang of Mine; Nov 78; Sawyer E.L.  
 Well, Maybe a Sniffle or Two...; Feb 79; Pattie M.T.  
 What Are We About? (Fragments, Fignments, or What?); Dec 75; [redacted]  
 What Ever Does 'However' Mean?; Nov 77; [redacted]  
 What Ever Happened to CYPES?; Jan 78; [redacted] W.E.  
 What If the Linguists Disappeared?; Jan 77; [redacted]  
 What Is a Collector?; Aug 74; [redacted]  
 What Is an Information Research Analyst?; Aug 77; [redacted]  
 What Is Cipher Text?; Feb 76; [redacted]  
 What Is Pattern Recognition?; Dec 77; [redacted] D.A.  
 What Language Problem?; May 76; Pattie M.T.  
 What Made Them Do It? (Language Self-Study); Dec 77; [redacted]  
 What Promotion Boards Want; Aug 82; [redacted]  
 What Should You Expect? or, The Analysis of Cryptanalysts; Aug 74; [redacted]  
 What To Do About 'FANX'; Apr 80; [redacted]  
 What's the Best Location for the Computer Applications Function?; Apr 76; [redacted]  
 What's The Good (Pass)Word?; Oct 82; [redacted]  
 What's Wrong with AG-22/IATS?; May 76; [redacted] D.R.  
 What's In a Name?; Dec 76; [redacted]  
 What's In a Non-Name?; Sep 78; [redacted]  
 When Censorship Backfires; Nov 75; [redacted]  
 Where Do Good Transcribers Come From?; May 79; [redacted]  
 Where Does 'Does' Come From?; Jun 75; Tetrault E.W.  
 Where Were We?; Jan 77; Mason P.O.  
 Which Numbering System Should We Use?; Oct 77; 'Asken'  
 Which Tape Has the Intelligence? Project CRISELOR; Jul 77; Gurin J.  
 Whither the SRA?; Sep 77; [redacted]  
 Who Wants A Promotion, Anyway?; Jun 82; [redacted]  
 Why Are These People Smiling?; May 77; Harrison M.A.  
 Why Can't They Design a Good SR Test?; Dec 76; Bjorklund K.  
 Why Do They Leave?; Jan 81; [redacted]  
 Will It Really Do the Job?; Oct 78; [redacted]

Will the Real ELINT Please Stand Up; Apr 76; [redacted]  
 Wilt Thou, Angelina ...?; Jul 79; Fairbanks S.  
 The Winnah: Kid Apostrophel; Oct 76;  
 Word Processing In A4; Apr 82; [redacted]  
 Word Seek; Mar 78; [redacted]  
 Work Quotas for Soviet Translators; Oct 76; [redacted]  
 W.W.II Japanese Translation at Arlington Station; Jan 79; [redacted]

P.L. 86-36  
 EO 1.4.(c)

# Y

The Yawn of the Computer Age or When Your Terminal is Terminal; Jan 75; [redacted]  
 Ye Gads! Another Country Trigraph System; Jul 78; [redacted]  
 Yes, Don, There is an ELINT!; Aug 76; [redacted] W.L.  
 You Can't Tell the Wheat from the Chaff Without a Program; Oct 78; Gurin J.

# Z

P.L. 86-36

ZBB? What In the World Is That?; Jul 77; [redacted] W.E.



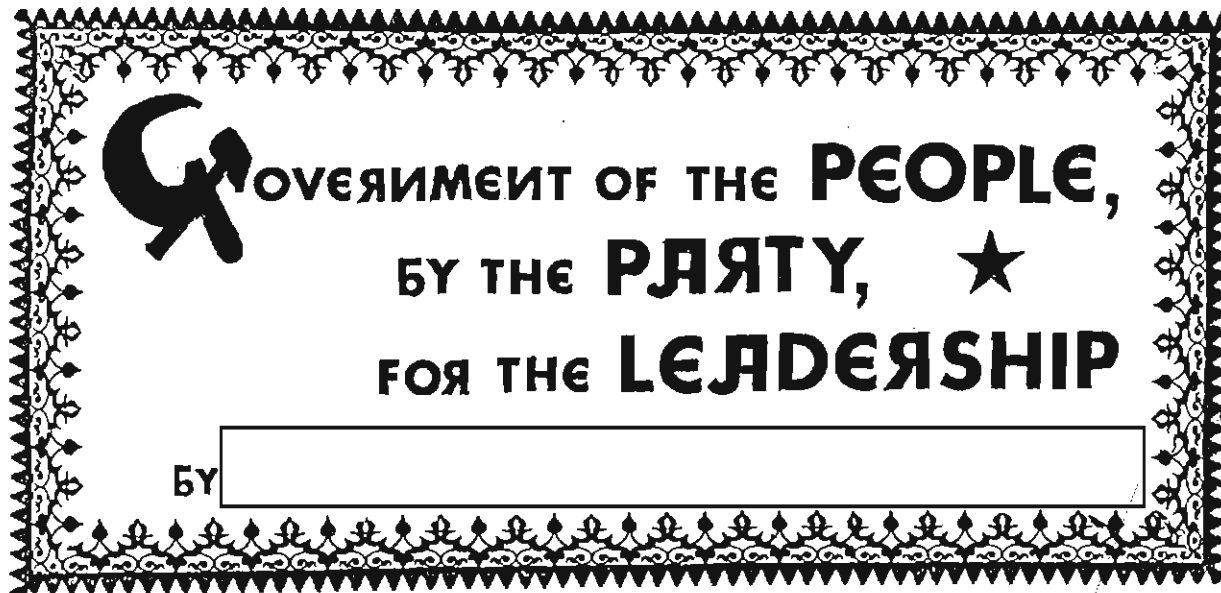

P.L. 86-36

**T**he American student who spends a summer or a semester in the Soviet Union is usually quite impressed when he or she is given the customary tour of the Kremlin and is told about the Soviet government. It seems very similar to what one finds in the Western democracies. There is a bicameral assembly called the Supreme Soviet which meets in the ultramodern DOM SOVETOV, the House of Congresses. The Supreme Soviet, like the US Congress or British Parliament, is bicameral in that it consists of two bodies: the Soviet of Union, to which representatives are apportioned by population (one for every 330,000 citizens), and the Soviet of Nationalities, in which every political entity has a constitutionally determined number of deputies (32 for each republic, 11 for each autonomous republic, etc). These representatives and deputies are elected by the citizens of the Soviet Union and they, in joint session, elect the Presidium of the Supreme Soviet which handles the Supreme Soviet's business when the body is not in session. The chairman of the Presidium is very similar to the European idea of a president; he has very little power but he is the official representative of the Supreme Soviet and the Chief of State (PREZIDENT).

NOTE: This article was written before Brezhnev's death, but the situation is still so fluid that any statements made about Andropov might be obsolete before this article gets published.

Leonid Brezhnev was Chairman of the Supreme Soviet from 1977 until his death in November, 1982, and his successor Yuri Andropov was quickly elected to the post. (See NOTE.)

The Supreme Soviet also officially appoints the members of the Council of Ministers. This is the highest executive and administrative organ in the USSR and its chairman functions in a manner similar to a European Prime Minister. He is the person charged with the efficient functioning of the immense government bureaucracy and the proper coordination of the ministries sanctioned by the Soviet constitution. Alexei Kosygin was the Chairman of the Council of Ministers for almost 20 years; since his death the post has been filled by Nikolay Tikhonov.



For a simplified illustration of how the elective and appointive processes work, see Figure 1.

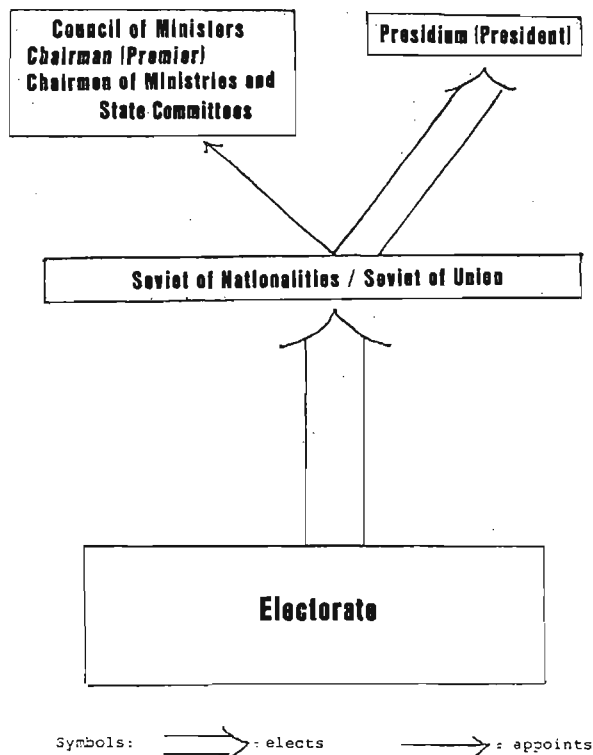

Symbols:  $\Rightarrow$  : elects  $\longrightarrow$  : appoints

Fig. 1: The Government of the USSR (Theory)

But there are some very fundamental differences between the actual operation of the Soviet government and the way that Western democracies function. One of these differences should eventually become apparent to even the most apolitical visitor: The Soviets have equipped the DOM SOVETOV with a huge stage and orchestra pit and the use the House of Congresses for ballets when the Supreme Soviet is not in session. After three or four months of spectacular performances, our student might begin to wonder if the Soviet congress is ever in session. If he or she is in Moscow on a one-year program, that curiosity would really grow, for the entertainment never seems to stop for very long.

The explanation of this puzzle lies in the nature of the Supreme Soviet's deputies and their duties. They are elected by the citizenry, but the selection of the candidates is made by the Communist Party and those candidates are elected without opposition.

Secondly, when the representatives and deputies do meet in solemn session, it is to ratify and formally approve actions, positions, and appointments that have already been made by the Communist Party leadership. There is no discussion or debate; still less is there any introduction of new alternative items on the agenda at the behest of the representatives' constituents.

Finally, since the actual functions of the Supreme Soviet are so restricted, its sessions are very short, usually lasting only a few days. Thus the actual government functions very nicely with its official legislative branch out of session about 350 days of the year.

The Soviet government in practice is shown in Figure 2.

Fig. 2: Actual operation of the Soviet government

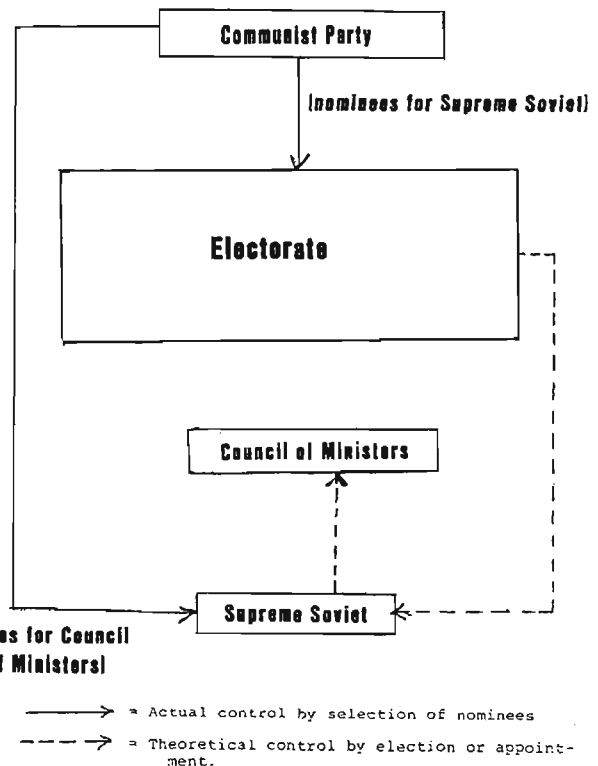

It would not be fair to say that the Soviet government is a facade designed to impress foreigners, for parts of it are the results of national experience that far antedated the Revolution. For over a thousand years the Russians have had authoritarian governments; changes, when they came, were decreed by the tsar, not demanded by outraged citizens. Representatives of the people, when they appeared, came to present a problem, not to make a decision or demand the enforcement of some regulation. Lenin's contribution to this tradition was an absolute requirement for discipline within his party. At the time of the Revolution this was a matter of survival. Without the discipline that Lenin had inspired, the Bolsheviks would have soon disintegrated into impotent bands of squabbling revolutionaries.

The trappings of democracy are important, albeit cosmetic. They provide an aura of participation in the formalities of government to the Soviet citizen without giving him any actual power or responsibility. These are the jealously guarded prerogatives of the Communist Party.

THE COMMUNIST PARTY

In theory the Communist Party structure is basically democratic, with the members at all levels being elected by those under them. The official apex of the Party structure is the Central Committee, which had 319 full members in 1981. The administrative control of the Party's own agencies and operations is in the hands of the Secretariat and the day-to-day execution of the Central Committee's mandates is entrusted to a standing committee called the Political Bureau or the Politburo. (See Figure 3.)

In practice, however, the flow of power and control within the Party is unidirectional--from the top. The Politburo is the apex of party control and the prime formulator of party policy. It is a collegiate body, containing within itself those key government officials and ministers who will actually implement its decisions. It is the Politburo that introduces the legislation or changes in the Constitution that will be ratified by the Supreme Soviet. And it is the Politburo which determines its own membership and that of the Secretariat.

The Secretariat is the most powerful administrative and executive organ in the Party. Besides directing all of the Party's internal and external affairs, the Secretariat also decides which Party members will stand for unopposed election to the Central Committee. (see Figure 4.)

There is little chance for serious conflict between these two bodies because many of the secretaries of the Communist Party are also members of the Politburo and, traditionally, the First Secretary of the Communist Party is also primus inter pares on the Politburo. Oddly enough, it is within the Politburo that free debate and discussion can intrude. The members of the Politburo can and do elect their own leader; Brezhnev's forte over the years was his ability to find consensus within this group.

Brezhnev served as First Secretary of the Communist Party, starting in 1970. Therein lay the source of his power, for within the Party he was the prime policy maker, the chief executive, and the ultimate nominator to party and government positions.

While there were policy discussions within the Politburo, all of the participants follow

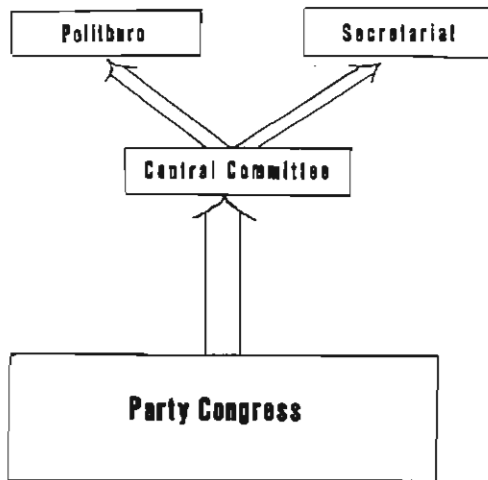

Symbols: = elects

Fig. 3: Theoretical structure of the Communist Party

the same ground rules and, by the end of Brezhnev's regime, most of them owed their exalted position to his influence. Opposition, if voiced, would tend to be circumspect. Furthermore, once decisions were made, both party instinct and self-preservation required an absolutely solid front to the rest of the world and to the party/governmental structure below them.

As the General Secretary of the Communist Party, Brezhnev did not need to negotiate. Everyone nominated for a Party or governmental position, whether he or she was to be appointed or go through the formality of an election, fell under his purview.

With that much power concentrated in his hands, one may wonder why Brezhnev even bothered to become PRESIDENT. Indeed, for many years the post was considered a dead end for careers and was used as an upper-echelon dumping ground where an old apparatchik could be deposited with many honors but no influence. Brezhnev may have had some personal reasons: he had the power, so why shouldn't he have had the honors too? However, being president had other advantages, especially in the area of protocol. When he was only the General Secretary of the Communist Party, Brezhnev had run into some awkward situations, especially when visiting Western nations; his only civil position was merely that of a humble delegate to the Supreme Soviet (from a district of his own choosing) and thus he had to go through the motions of deferring to the Premier or the President when one of those chiefs of government was a member of the official party. As Chief of State, he was able to receive 21-gun salutes and to review honor guards without encumbering himself with any onerous additional responsibilities.

**PARTY CONTROL OF THE GOVERNMENT**

While the domination exercised by the Communist Party over a supposedly democratic society may be abhorrent to the Western mind, there is no doubt about its status under Soviet law. Article 6 of the Soviet Constitution states:

The leading and guiding force of Soviet society and the nucleus of its political system, of all state and public and social organizations, is the Communist Party of the Soviet Union. The CPSU exists for the people and serves the people.

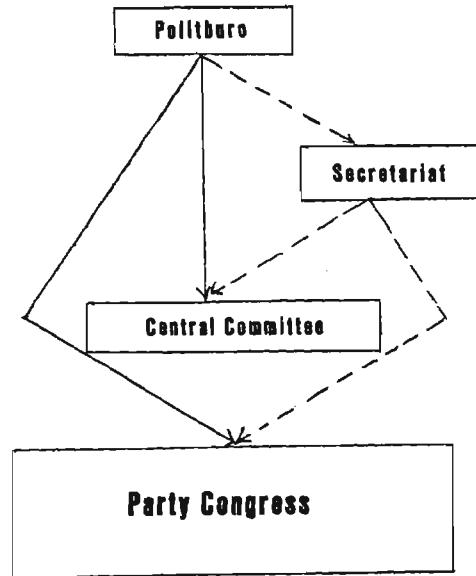

Symbols: - - - -> = Control by selection of nominees  
 ———> = Control by selection of policy

Fig. 4: Actual operation of the Communist Party

The Communist Party, armed with the teachings of Marxism-Leninism determines the general perspectives of the development of society and the course of the home and foreign policy of the USSR, directs the great constructive work of the Soviet people, and imparts a planned, systematic and theoretically sound character to their struggle for the victory of Communism.

All Party organizations shall function within the framework of the Constitution of the USSR.

This is a key article in the Soviet Constitution and merits careful reading because:

1. While the CPSU is defined as existing for the people and serving the people, nowhere does it say that it is elected by or answerable to them.
2. It imparts blanket authorization to the CPSU to direct all state, public, and social organizations with the society and to determine internal and external policy without authorizing any group or agency

external to the Party to decide what should be included under these terms. If the party decides that stamp collectors constitute a social organization needing party direction, willy-nilly they will get that direction.

3. While many admirable rights are provided for individuals and groups under this constitution, the exercise and ultimate specification of these rights will be under the guidance of the Communist Party. Furthermore, the enforcement of these rights will be by agencies which will be under Party control.

There can be no doubt about the official status accorded to the Communist Party under the constitution. It has been given a license to kill. The only question that remains is how it exercises this power.

Figure 5 shows the various echelons of Soviet government and Party organizations. At first glance it would seem that we are dealing with two corresponding but separate entities, but this is not so. At each echelon the party exerts its power laterally to the corresponding governmental level and down to the subordinate Party organizations.

The Party exercises its control laterally through a combination of appointments and dual responsibilities. To begin with, all government officials at the upper levels are Party members and are subject to Party discipline. Furthermore, their appointment (or nomination to elective office) was authorized and approved by the Party bureau or secretariat. This is the situation that obtains throughout the ministries and directorates and committees under the Council of Ministers. However, there are some key positions that the Party officials have appropriated for themselves, resulting in one individual wearing two hats: one as a Party functionary and another as a government official. Leonid Brezhnev was a good example of one man riding two teams of horses: he was the General Secretary of the Communist Party and the dominant member of the Politburo; he was also the representative of the Bauman District in Moscow to the Soviet of Union and, last but not least, Chairman of the Presidium of the Supreme Soviet (PREZIDENT). Within the Party, Andrei Gromyko is a full member of the Politburo, as well as the Minister of Foreign Affairs and a member of the Council of Ministers. Another such minister who is also very prominent in the Politburo is Minister of Defense Dmitri Ustinov.

Yet the Politburo is unique in its composition. Its membership is completely open, both in number and official status. If the Politburo decides that someone's input is necessary or useful, he will be elevated to membership, at least as a candidate. Its present membership includes national, oblast, and city officials. For example, Vladimir V. Shcherbitskij is the Ukrainian Party Secretary, Grigorij V. Romanov is the First Secretary of the Leningrad Oblast party organization, and Viktor V. Grishin is the Moscow City First Secretary.

Also, since the Politburo is first and foremost a standing committee of the Party, a member does not have to hold a high governmental post in order to exert considerable influence. We have already seen that Brezhnev's governmental post was quite humble long after he had effectively taken control of the country. Similarly, the late Mikhail Suslov, who was in the Politburo for a quarter of a century and exerted enormous influence, served for years as the chairman of an obscure commission in the Council of Union.

#### PARTY CONTROL OF THE MILITARY

The Soviet military establishment appears to be similar to those of Western nations in that it is a ministry of the civilian bureaucracy. It is headed by a minister who is subordinate to the Premier and Chairman of the Council of Ministers. Like all the other state public and social organizations in the Soviet Union, it is under the guidance and leadership of the Communist Party according to the provisions of Article 6 of the Soviet Constitution.

However, there are other historical and social factors that make the military different. The party, whether headed by Lenin or Stalin or Khrushchev, has long realized that the military is one organized, disciplined, and armed organization with loyalties of its own that could be a real threat to Party control; for this reason they have kept it under particularly close scrutiny and have been reluctant to put the military in policy-making positions. While professional military men have been appointed Minister of Defense, the only one to be allowed into the Politburo since Stalin was the late Marshal Grechko, except for Marshal Zhukov, who was a member for a few months after Khrushchev seized power but was quickly eased out.

This is also one situation where personalities can make discerning the tail from the dog

difficult. Dmitri Ustinov, as Minister of Defense, is officially answerable to the Premier, Nikolaj Tikhonov. But, within the Politburo, Ustinov outranks the Chairman of the Council of Ministers, both in seniority and patronage.

The Soviet military differs from its western counterparts in that the Party does not have its functionaries actually running military positions or directorates. They realize that such an intrusion would seriously affect operational efficiency. But in other ways surveillance, if not control, follows the familiar pattern. To begin with, virtually all officers of field rank (major or equivalent) and above are members of the Communist Party, with a significant number holding elective positions in the government and the Party. This puts them under Party discipline and gives them Party obligations that could dilute their interests and obligations. As in the civilian sector, there is a separate Party organization following the military structure down to company level. (See Figure 6) This constitutes a separate chain of command. The man at the top, Gen-Army Yepishev, is accountable directly to the Politburo although he is administratively subordinate to the Minister of Defense and reports to him on the status of troop morale, discipline, and political work.

There is always the possibility, of course, that the Party watchdogs might develop a cozy, overly sympathetic relationship with the objects of their scrutiny. To avoid this, the Party has built almost baffling layers of redundancy into its surveillance: the Komsomols, the local Party organizations, and the military councils back up the military Party chain. The Procuracy and the Party Control Committees have their own direct lines to the Politburo....and keeping book on how well all of them are performing are the ubiquitous agents of the KGB (Committee for State Security). If anyone anywhere in the military is doing or thinking something heretical, someone will be informing the Party leadership.

departments within the Ministry of Defense are perhaps even more confusing. But most of this is simply an extension or refinement of what has been presented here. The Soviets are remarkably consistent in this regard.

As this article was being written, it was announced in open sources that Andrej P. Kirilenko had retired from the Politburo. Shortly thereafter, the death of Leonid Brezhnev occurred followed by the accession to power of Yurij Andropov. But the nature of the Communist Party and the way it controls Soviet society will remain constant; the offices of PRESIDENT and General Secretary will not change. Indeed, a basic understanding of this system will be even more necessary as the survivors and their factions within the Politburo scramble for power in post-Brezhnev Russia. Without this understanding, you not only do not have a scorecard; you don't even know the rules of the game!

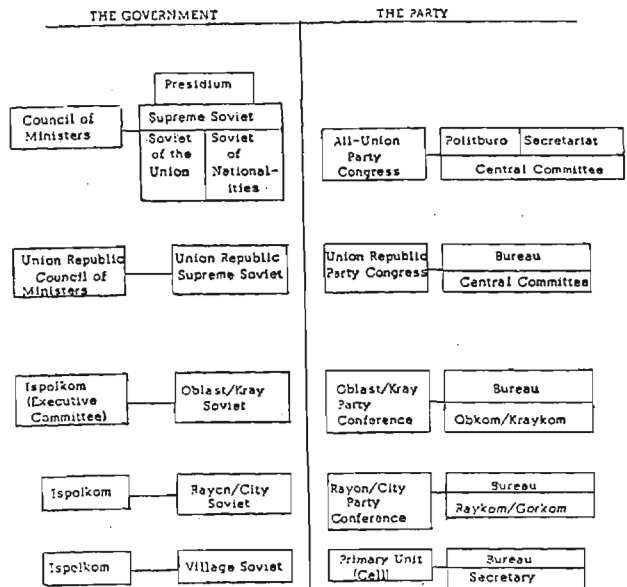

Fig. 6: Party and Government Echelons

CONCLUSION

Much more detail would have to be added to begin describing the civil, military, and Party structure of the Soviet Union completely: the lists of ministries and bureaus and committees and commissions in the Soviet Union and its member republics are almost endless. The various commands, directorates, and

AFTERWORD

The author would like to express his gratitude for the advice and assistance he received from Marc Brenner of the National Cryptologic School, who read the original drafts and provided invaluable source materials and who supplied the material for Figures 1 through 4. He also read over the original manuscript (prepared as a report while the author was serving as a Foreign Area Officer for the Army ITAC at FANX).

Organization of the Main Political Directorate of the Soviet Army and Navy (MPD)

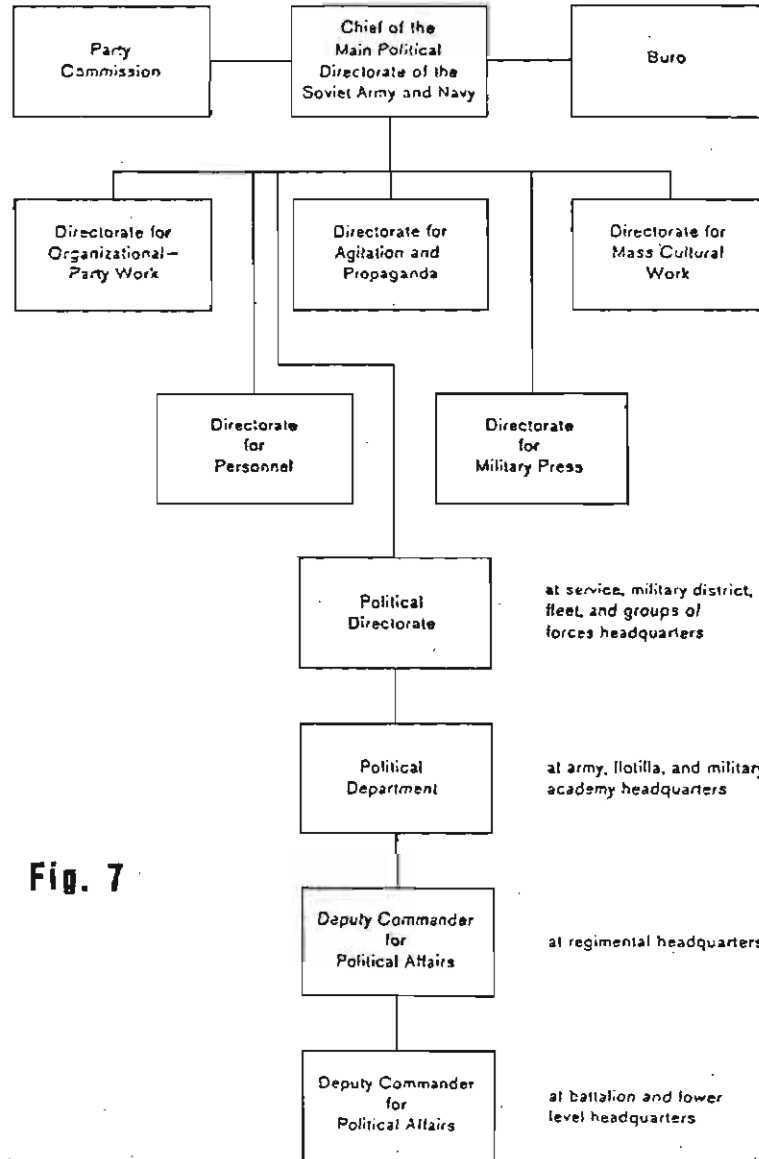

Fig. 7

# SPECIFYING COLORS FOR COMPUTER GRAPHICS

by



P13

P.L. 86-36

The user of a color graphics system is frequently faced with the need to describe or name various colors he wishes to use for CRT displays. It is important for the user to be able to specify the exact hue, saturation, and lightness he wishes the colors to have. It is also necessary to specify the colors in such a way that typical color graphics systems can realize and display them. An article in the August issue of Communications of the ACM describes two color notation systems in general use for this purpose, and contrasts them from a human factors point of view against a third system devised by the authors (T. Berk, et al., "A Human Factors Study of Color Notation Systems for Computer Graphics," Comm. ACM, Vol 25, No. 8, August 1982, p. 547).

A typical color graphics system can realize up to 4,096 different colors. There must be some system of description or notation, however, to permit the user to select and specify the color that comes closest to what he has in mind. The notation system must also let him vary the parameters of a displayed color until he gets what he wants. Two commonly-used color notation systems for graphics are the RGB and HLS methods. The RGB system requires a user to specify a color in terms of its red, green, and blue primary components, corresponding to intensities of the electron beams that excite red, green, and blue phosphors on the color CRT. This means, essentially, that the user must describe his colors in a way closest to the internal workings of the system and farthest away from his natural (cultural and linguistic) ways of seeing and naming colors. To make matters worse, the RGB expression

for a color consists of a triple of real numbers between 0 and 1, for instance [0.73, 0.63, 0.05]. This is a very cumbersome and unnatural way to describe a color for most people.

The HLS system allows the user a more natural way of specifying colors, in terms of hue, lightness, and saturation. Unfortunately, the mode of representation still depends on a triple of real numbers. For example, the same color used in the example of RGB above (a shade of yellow) would be shown as [0.142, 0.73, 0.93] in HLS. What is needed is a notation that provides the user with a natural and convenient way not only of describing the color he has in mind, but also of entering it into the system in some higher-level language so that it may be converted behind the scenes to the RGB-type internal representation required by the graphics system.

Well, how do people think and talk about colors when they are NOT using color graphics? In fact, color names (and, in some cases, even the number of different colors distinguished) are a matter of language and custom, varying among different cultures. Some cultures, for example, do not distinguish green from blue as we do, but call the whole range of hues between our green and blue by one name. As English speakers, we take for granted certain specific ways of describing and relating colors in a kind of "color space" with several dimensions along which we perceive colors to vary. When we are talking to other people

about colors, we can make use of a large vocabulary of specialized color words like "beige," "mauve," or "magenta," or phrases such as "Kelly green" or "burnt umber." As the paint salesman can testify, it is hard to communicate color changes or relationships accurately and operationally using this set of words ("Make it more beige." "I want a kind of tangerinish color but more toward the gold, kind of like a winter sunset!") But we also have another more logical linguistic system for color descriptions using a small number of color names which may be preceded by one or more adjectives, e.g., "vivid blue," "reddish yellow," "very dark purple." In this system, we might say "Make it more reddish" or "Make it lighter" to describe a change that would move a perceived color closer to a target area in our "color space."

Berk *et al.* have devised a third formal notation for colors, the CNS system. It is intentionally designed to be as close as possible to the natural English method of using color names and adjectives. The CNS system is based on a color lexicon of the Inter-Society Color Council and the National Bureau of Standards (ISCC-NBS). The syntax of CNS is shown below, with some sample color descriptions:

```

<color name> ::= <achromatic name> | <chromatic name>
<achromatic name> ::= [<lightness>] GRAY | BLACK | WHITE
<chromatic name> ::= <lightness> <saturation> <hue> |
    [<saturation>] [<lightness>] <hue>
<lightness> ::= VERY DARK | DARK | MEDIUM | LIGHT | VERY LIGHT
<saturation> ::= GRAYISH | MODERATE | STRONG | VIVID
<hue> ::= <generic hue> | <halfway hue> | <quarterway hue>
<generic hue> ::= RED | ORANGE | BROWN | YELLOW | GREEN |
    BLUE | PURPLE
<halfway hue> ::= <generic hue> - <generic hue>
<quarterway hue> ::= <ish form> <generic hue>
<ish form> ::= REDDISH | ORANGISH | BROWNISH | YELLOWISH |
    GREENISH | BLUISH | PURPLISH
    
```

Either or both lightness and saturation may be omitted and, in their absence, "MEDIUM" and "VIVID" are assumed. Only hues which are next to each other in the list may be combined to form halfway and quarterway hues. A total of 627 color descriptions can be generated.

Examples

```

achromatic:
    DARK GRAY; BLACK; VERY LIGHT GRAY; WHITE.

chromatic:
    YELLOW, YELLOWISH-GREEN; YELLOW-GREEN;
    MODERATE BLUE; LIGHT GRAYISH RED-ORANGE.
    
```

A human factors experiment was carried out to compare the accuracy with which people could describe colors using the three systems RGB, HLS, and CNS. The 37 subjects were computer science students at the Florida International University. An approximately equal number of students were taught each of the three systems, and then asked to give specifications for 20 different test colors on glossy pigment samples from the Macbeth Color Checker Color Rendition Chart. For each response, a distance was computed (measured in NBS Color Difference Units) between the color on the chart and the color the student's description would generate. The larger this distance turned out to be, the less accurate was the description. A 3x20 two-way analysis of variance found the effect of the notation system to be statistically significant ( $p < 0.001$ ). The RGB users were least accurate, HLS were next, and CNS were most accurate.

The authors note that CNS provides users with a relatively limited choice of discrete small regions along the three dimensions of the color space, while RGB and HLS provide a much larger and apparently more flexible set of choices. It might be expected, therefore, that users would have more trouble describing

colors accurately using CNS. In fact, the opposite was true. Clearly, the naturalness of the CNS method more than offset any lacks it might have had in "power" or "flexibility." Berk *et al.* close their brief technical note with a summary that has wide-ranging implications for software design far beyond the limited area of color graphics: "In sum, the results of this experiment confirm the importance of human factors considerations in software development. In this instance, it has been shown that giving a user choice from a small set of values that are carefully chosen and based on human factors principles can produce better accuracy than providing a much larger and apparently more flexible set of values that are not based on such principles."





P.L. 86-36

by



P13

# A

Globecom 82 meeting described a number of related projects to provide rural African villages as small as a few hundred people with modern satellite communications. The ITU (International Telecommunications Union) has sponsored and coordinated a number of these projects, and there have been meetings in Addis Ababa, Bangkok, Geneva, and Paris in the past few years on this topic. Significantly, the West German Ministry of Economic Development has set aside \$500 million to finance the development of African telecommunications (and, incidentally, to create a market for German high-technology products). Traffic forecasts estimate as much as 15,000 erlangs of traffic to be carried over 20,000 two-way satcom circuits. An initial satellite, with 12 transponders which could each carry 600 two-way voice circuits (500 erlangs of traffic per transponder) could be in service in 1986 if the earth station problems could be solved. An erlang is an international (dimensionless) unit of the average traffic intensity of a facility during a period of time, normally an hour. The number of erlangs is the ratio of the time during which a facility is occupied (continuously or cumulatively) to the time this facility is available for occupancy.

(U) If this African domsat project is carried out, it could create a major change in global telecommunications during the next decade.

(U) Because rural Africa has virtually no surplus wealth, it would ordinarily be impossible to finance telephone links to the towns by either landline or satellite. On the other hand, the demand for telephone service is

intense; in market towns the Africans will wait in queues all day to make a call from a public phone. Current telephone plant in rural Africa, where 85 percent of the population lives, is about 160,000 phones to serve a population of 250 million people. In essence, the sub-Saharan African countries can scarcely provide telephone service in their major cities and communications into the rural area, except for sound broadcasting, are generally limited and uncertain.

(U) The existence of the West German fund had put African telecommunications in a new light because it is now possible to capitalize a large-scale project. Apparently the aim of the German Government is to apply the money as part of its foreign aid program and, at the same time, create a market for the products and services of their very capable telecommunications manufacturers. Some of the money has already been used to fund ITU studies of rural African telecommunications and if the German scheme is enacted, the whole pattern of domestic intracountry African communications will undergo rapid and drastic change.

(U) Because demand-assigned single-channel voice circuits over satellite relay are favored as the best solution to rural telephony, the proposed transformation would eventually connect several hundred thousand villages and towns all over sub-Saharan Africa through a satellite relay. Three or four narrow spot beams would cover the continent from the southern edge of the Sahara to the border of South Africa. Thin-route terrestrial links, e.g., VHF single-channel radio links, would connect the smallest villages to the hamlets where the earth stations were located.



Between 10 and 50 percent of the rural traffic would connect into the major cities, so that the traffic content would reflect the complete infrastructure and internal activities of the countries and the wide range of languages and dialects that flourish throughout the continent.

Rural Communications

(U) The problem of rural African communications has been under study by the ITU and by private interests for some time. [1-10] One proposed satellite would use three 7° spot-beams at 4-to-6 GHz to cover most of Africa. Variations on this would use one 12° beam or four 4.5° beams. The narrower the beams the less power needed both in space and on the ground, but satellite complexity increases. The satellite, which would cost \$200 million, would have to have high power and high sensitivity to allow the use of small, "cheap" earth stations. Some of the design ideas are very similar to concepts presented by Lusignan and his team at the Stanford University Communication Satellite Planning Center. (Libya and Mexico have adopted the CSPC software for their network planning.) The three downlink beams would operate at 4.0 GHz with 20 watts of power (eirp), "backed off" 5 dB. Because of the high elevation angles the downlink rain loss would be negligible at 4.0 GHz.

(U) The uplinks to the satellite would operate at 6.2 GHz with 3-meter antennas. For the 3-beam system, uplink power would be 0.5 watts and the antenna gain of 43.6 dB would give an earth-station eirp of 39.6 dBW.

(U) The earth stations are the crucial element of the system because of the need for low cost, ruggedness, and extreme reliability. The lack of electric power in the small towns and villages, for the foreseeable future, is a critical factor in feasibility. More than half the African population lives in tiny villages with neither transportation nor lighting.

Table: Distribution of Rural African Population

Size of Village	Number of Villages	Mean Pop.	Total Pop.
0 - 400	324,000	200	64 million
400 - 1000	106,000	700	74 "
1000 - 4000	35,380	2,500	88 "
4000 -10000	3,503	7,000	24 "
Total			250 million

(U) Terrestrial nets already serve 160,000 phones. A combination of terrestrial nets, e.g., VHF single-channel radio links and satellite links in larger villages, would be used to serve a total population of 250,000 phones. The smallest villages would have no telephones. The traffic demand is estimated at .05 erlangs for the 700-person village (about one 3-minute call per hour during the busy part of the day). This aggregates over the thousands of villages to about 3,500 erlangs of traffic in the rural area, supplemented by 10 to 50 percent additional traffic to the urban centers. Traffic from the larger towns would increase this volume to about 18,000 erlangs.

Table: Distribution of Rural Traffic

Size of Village	Traffic Demand	Number of Phones	Total Demand (+50% Urban)
0 - 400	-	-	-
400 - 1000	.05 erlangs	106,000	5,300
1000 - 4000	.15 "	106,000	5,300
4000 - 10000	.50 "	38,000	1,760
Total			12,360
Total Demand (+50% Urban)			18,525



(U) Because the economies and tribal relations frequently extend across the arbitrary borders of African nations, the rural traffic will often be transborder traffic unless the national PTTs prohibit this. Equipment will limit traffic growth, even if funding is available, for a typical transponder can carry only 600 two-way circuits and, to keep blocking below 1 percent, only 500 can be used for peak traffic. Another 10 circuits would be used for channel assignments and requests. DAMA (Demand-Assigned Multiple Access) will provide geographical flexibility, but a typical satellite with 12 transponders can carry only 6,000 erlangs of traffic. If such a satellite was launched in 1985-6, it would probably reach saturation in the early 1990s and a second satellite with 12 more transponders (or a new satellite with 24 transponders to replace the 1986 relay) would be needed. The DAMA system would be centralized, with centralized billing. This would give the national PTTs virtually complete control of all the earth stations, tariffs, and interconnections. There would presumably be a regional satellite operating agency serving the member nations as an "Africa COMSAT."

Table: Service from 12 Transponders

Size of Village	Number of Telephones	Number of Villages to be Connected
0 - 400	-	-
400 - 1000	31,000	31,000
1000 - 4000	31,000	10,000
4000 - 10000	10,000	1,000

(U) This amounts to providing service to about one third of the villages of each size above 400 people, but over 300,000 smallest villages are left out of the satellite system in this initial system.

Earth Stations

(U) Once a satellite is put into operation, the spread and usefulness of the network depends on low-cost, reliable earth stations. A critical parameter for the SCPC design is frequency stability in both satellite and earth stations. Frequency accuracy of one part in 10 million is required in both the space and ground segments. Because the earth station will have to operate over a wide temperature range (as much as 50° Celsius), a reference standard is needed in each earth station. The earth station must have frequency agility to tune over 800 MHz in 30-KHz steps with errors no greater than 400 Hz and

600 Hz on the down and up links. Power is critical, for diesel generators are not considered a feasible power source in remote villages; the lacks of fuel, maintenance, and skilled operators are major problems. The earth station reliability criterion is that maintenance calls must be more than a year apart. This is a stringent requirement, but it is primarily a technical problem. The alternative would be a complex training program. The difficulty of training, operation, and maintenance for any kind of telecommunication equipment and power supply in rural Africa can be characterized in part by noting that with 1,700 local languages, instruction and advice and reference manuals of cassettes would have to be translated into hundreds of different languages.

(U) Small two-way earth stations with 3-meter dishes currently cost more than \$100,000, not including power. Because terrestrial circuits must be connected into the earth station to serve feeder links to smaller villages, it must have a PABX (Private Automatic Branch Exchange). Each earth station can handle up to 10 telephone circuits if power is available. A difficult interface problem occurs where the earth station must connect into an existing telephone system, e.g., in a medium-sized town, because old-fashioned manually-operated switchboards with R2 signaling must be interconnected to the high-technology low-power terminal electronics.

(U) The advocates of GLODOM (Global Domestic) rural satellite systems are trying to reduce earth station electronics costs to \$15,000, but even if they succeed the total cost for 3-meter earth stations will probably not go below \$30,000. If the German government does provide \$500 million for rural Africa's telecommunications and the space segment costs \$200 million, some 10,000 earth stations could be funded in the initial phase with the remaining \$300 million. This would equip only 7 percent of the villages and towns of more than 400 persons, but terrestrial nets could extend the coverage to many adjacent villages.

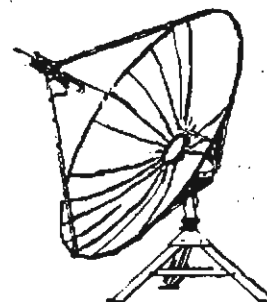

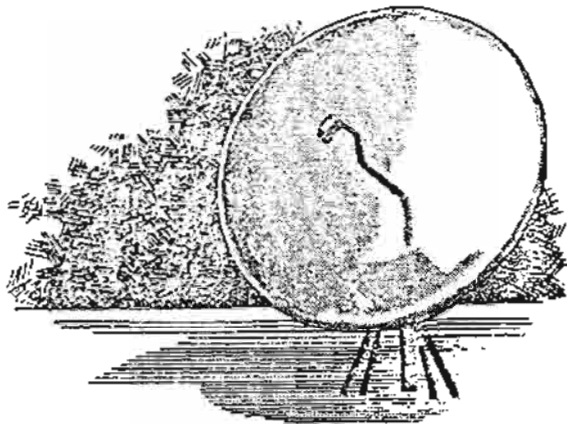

areas by HF radio circuits, with verbal descriptions of symptoms sent one way and medical advice and designations of specific treatments sent to the outstation. In the African context, telephony can be used to provide specific information and questions on agriculture, health, public health, weather, emergencies, etc., to improve health and the rural economy. This type of specific information is worth the cost of the call to the farmer, herdsman, or sick person.

(U) An important point that has not yet been resolved in planning rural African telecommunications is, even if a foreign grant capitalizes the initial plant, where will the operation and maintenance monies come from? In the case of potentially rich countries, which have oil or mineral resources, business customers and general revenues can be used to cross-subsidize the rural O&M costs. In the LDCs (Least Developed Countries), the only source of revenue is borrowing and the Western banks are becoming wary of the loans. On the other hand, World Bank studies have shown that telephone stations, even in poor countries, soon yield net revenues to the PTTs because of the value of the calls relative to other expenditures.

(U) Once an "early bird" Africasat network began to deliver services to the rural area, the extension of services would probably become a significant domestic political matter in Africa and the governments would apply persuasion to other nations to get additional funding in the form of loans, grants, etc., to extend the network. (At a 1980 meeting in the US one African Minister of Communications declared that telecommunications should be defined as a "basic human right," and the countries expect transfers of wealth and technology to provide these "rights.")

(U) Experience in South America has shown that once the primitive HF voice circuits are replaced by good-quality satellite voice circuits, the demand for long-distance traffic expanded sixfold overnight. African rural life centers around the market towns, where barter, trading, and other vital business transactions occur. Once telephone service to the larger towns and cities is available, a "hiding demand" for telephony is likely to be unleashed which presently cannot be seen in any conventional traffic studies. In a sense, the lack of transport and energy in the rural areas creates a greater demand for communications--a phenomenon manifested in the wide dispersion of sound broadcasting to over 19 million radio receivers.

(U) In addition to business traffic, growth in government traffic, personal traffic, and public service traffic also represent hiding demands, capable of explosive growth. In Australia medical services are provided to remote

(U) Major telecommunications companies have been very skeptical about the business prospects for rural African satellite systems. The World Bank has also been skeptical of satellites.[11] The high cost of even small earth stations for conventional satellite systems has made satcoms appear a hopeless investment prospect for some of the poorest nations in Africa. However, the use of sensitive receivers on the satellite, with narrow spot beams, comes closer to making small earth stations a feasible investment. More important, there have now been several years of studies and conferences under ITU auspices,

and the political leaders of both rich and poor nations are now thinking of telecommunications as a need which must be fulfilled by transfers from rich nations to Africa, without regard to return on investment.



(U) Africa itself is becoming increasingly significant to the economies, politics, and strategic interests of the rich nations. The section of Africa running East-West from Namibia to Swaziland, known as "High Africa," is considered to be the "Saudi Arabia" of the mineral world. By 1990 the US and many other advanced nations will be unable to produce steel economically unless they get manganese from Africa or the USSR. Many other vital minerals, (e.g., cobalt, chromium, uranium) will also have to be obtained from Africa. The USSR and several satellite nations have spread economic and political fieldworkers into many African rural areas. There are also military and trade rivalries spreading between the African nations and being imposed on Africa from other parts of the world.

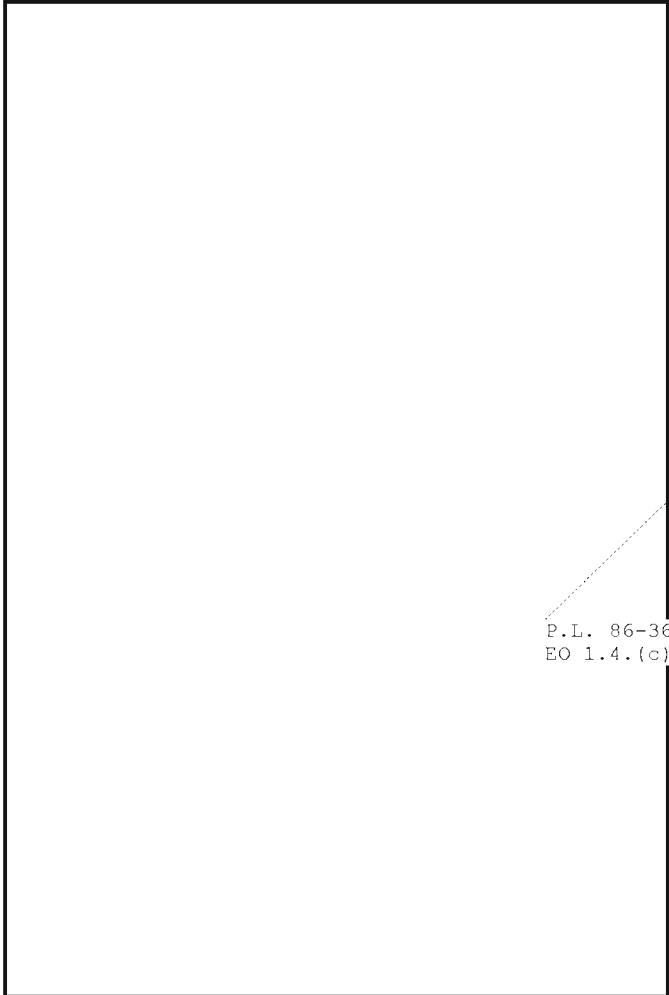

P.L. 86-36  
EO 1.4.(c)

~~(FOUO)~~ Many of these economic and political influences will be manifested in the small towns and rural areas, as well as in the cities. Thus, there are East Germans, Czechs, Russians, Cubans, and other Soviet-bloc fieldworkers in various African countries. In parts of Africa the British and French have considerable presence, dating from their colonial period. Revolution and guerrilla warfare also express themselves in the rural areas. The continuous tension between white South Africa and the politically volatile Black African nations just northward lies, not by accident, along the mineral-rich area of High Africa. Politics, enormous potential wealth, dynamic change, and high strategy are woven across the continent, much of which is almost unchanged by the last thousand years of history.

~~(C-CCO)~~ One of the striking features of communications in rural Africa is that almost all of Africa, outside the main cities, is inaccessible to the West. As R. Richter notes in her book Whose News? (p. 241), the African governments are very reluctant to let any reporters, even their own, get out of the cities to see what is happening in the rural areas, where most of the population lives. One by-product of the Africasat is that the urban Africans would be able to find out more of what was happening outside the cities, and this is apt to make the traffic content more valuable because of the dearth of other sources of information.

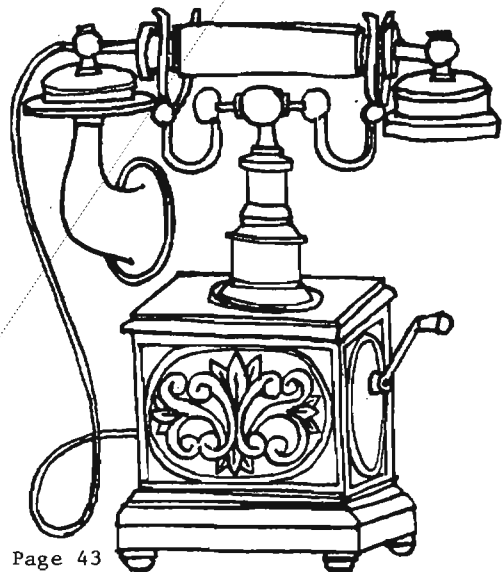
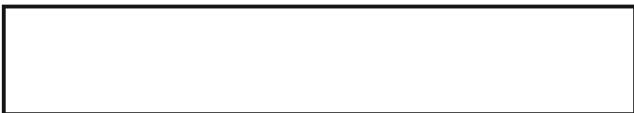

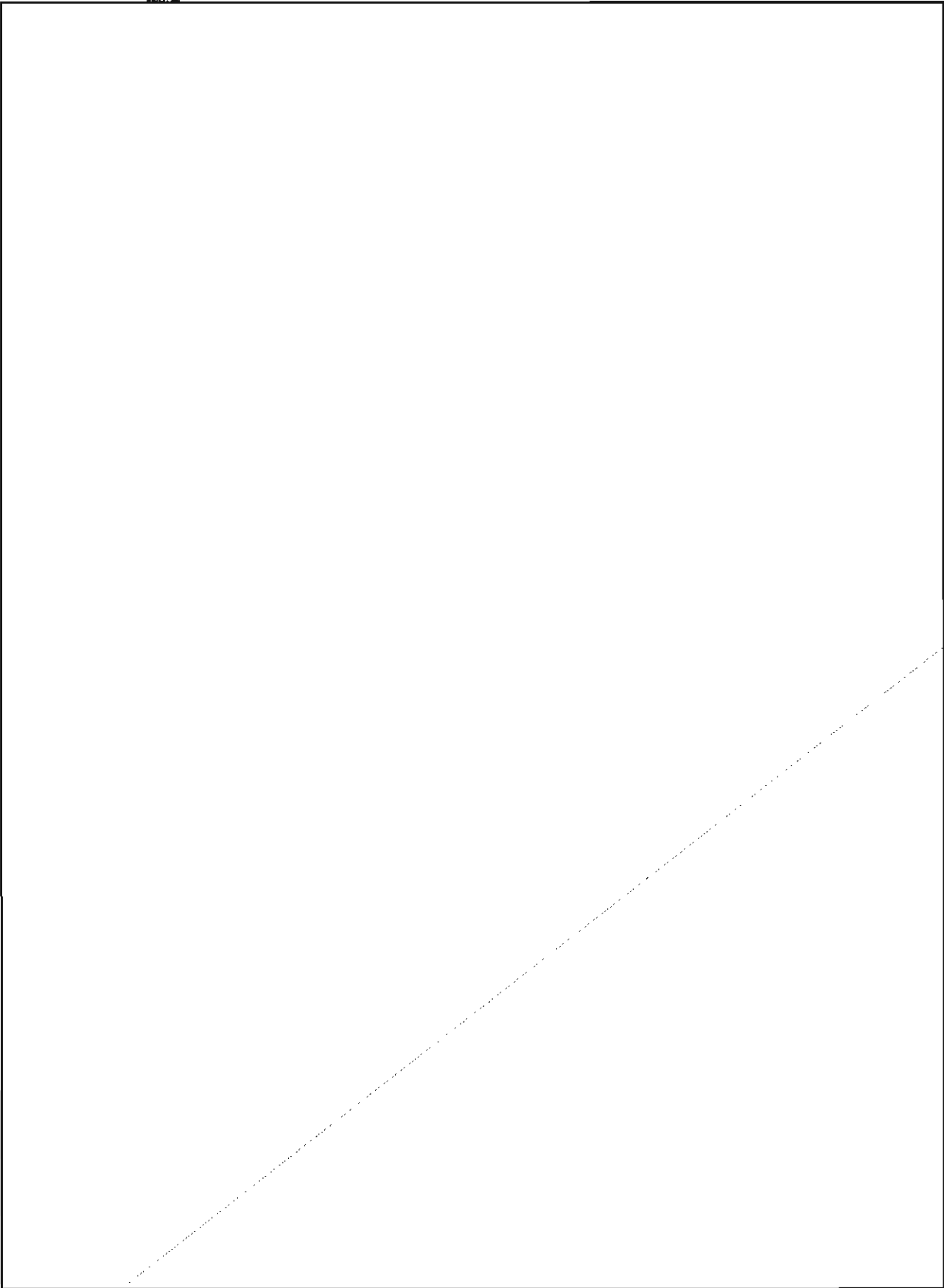

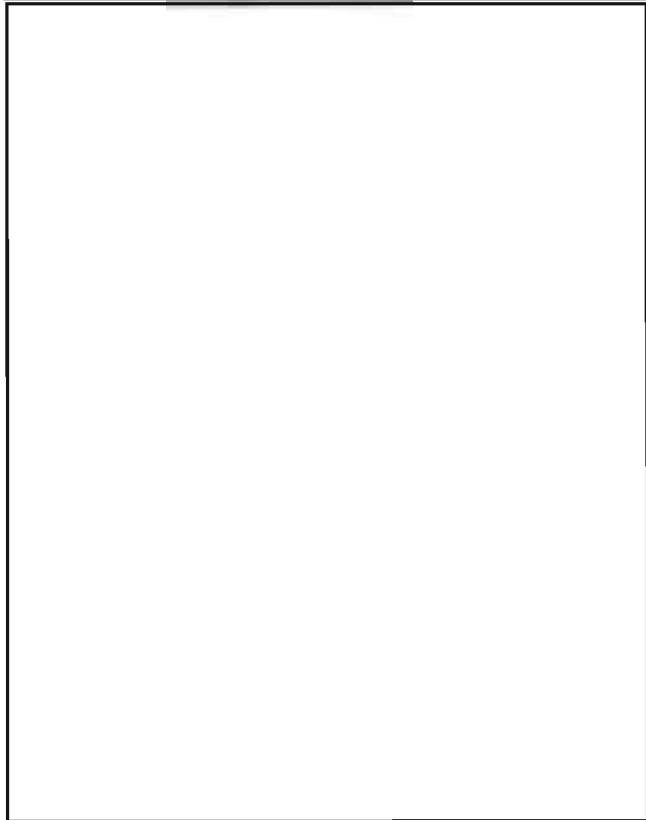
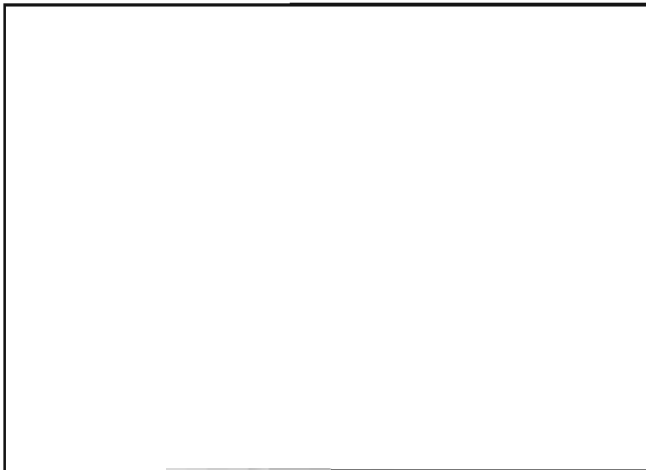

(U) The principal international languages in Africa are Arabic, French, English, and Portuguese. These would be spoken at a high level, or across long distances, as governmental and business languages. Within Africa there are a number of "lingua francas" such as Hausa or Swahili, which are spoken as second or third languages by millions of Africans who originally learned localized vernaculars. In Southern Africa the lingua francas are Fanagalo, Tswana, Lozi, Umbundu, Lwena, town Bembá, and Nyanja. Vernaculars in the same area include the Khoisan click languages such as !Kung, Hiechware, Kam, Nama Hottentot, Korana Hottentot, and Bantu languages such as Zulu, Xhosa, Tswana, Kololo, and Chokwe-Lunda.[13] In Eastern Africa Swahili, Ganda, and Amharic serve as lingua francas, while Somali is the vernacular over a large area at the Horn of Africa. (But a dialect of Somali is used as the lingua franca between the different Somali dialects.) Other well-known lingua francas are Luba (or Chiluba), Kituba, and Lingala in the Congo basin, while the Niger-Congo family contains several dozen vernacular languages used in the same area. In western Central Africa Bulu, Yaunde, Duala, Bali, Adamawa-Ful, and Sango serve as lingua francas. On the West African coast Yoruba, Ewe, Twi, Ga, Mende, Temne, Susu, and Wolof are used as lingua francas. In the W<sup>EO 1.4.(c)</sup> Sudan Hausa, Songhai, Mosi, Mandingo, Ma<sup>P.L. 86-36</sup> Dyula, Bambara, and Kangbe serve the same function. Bambara, for example, is widely used as a soldiers' language and was used by the French for military recruiting. Many of the languages are known by various different names, and there are different spellings and even different alphabets for some languages. The Click Languages use various punctuation symbols such as !, #, and & to express different click sounds. To summarize, the language situation is very diverse and complicated, and the impact of modern telecommunications will change the linguistic situation fairly rapidly.

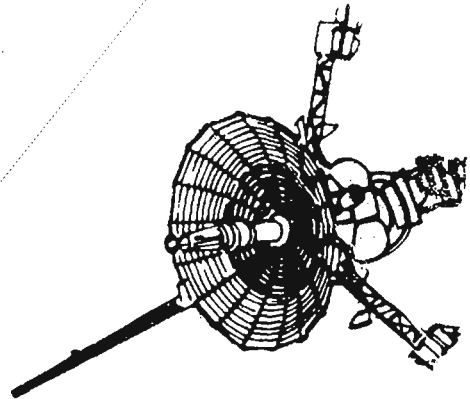

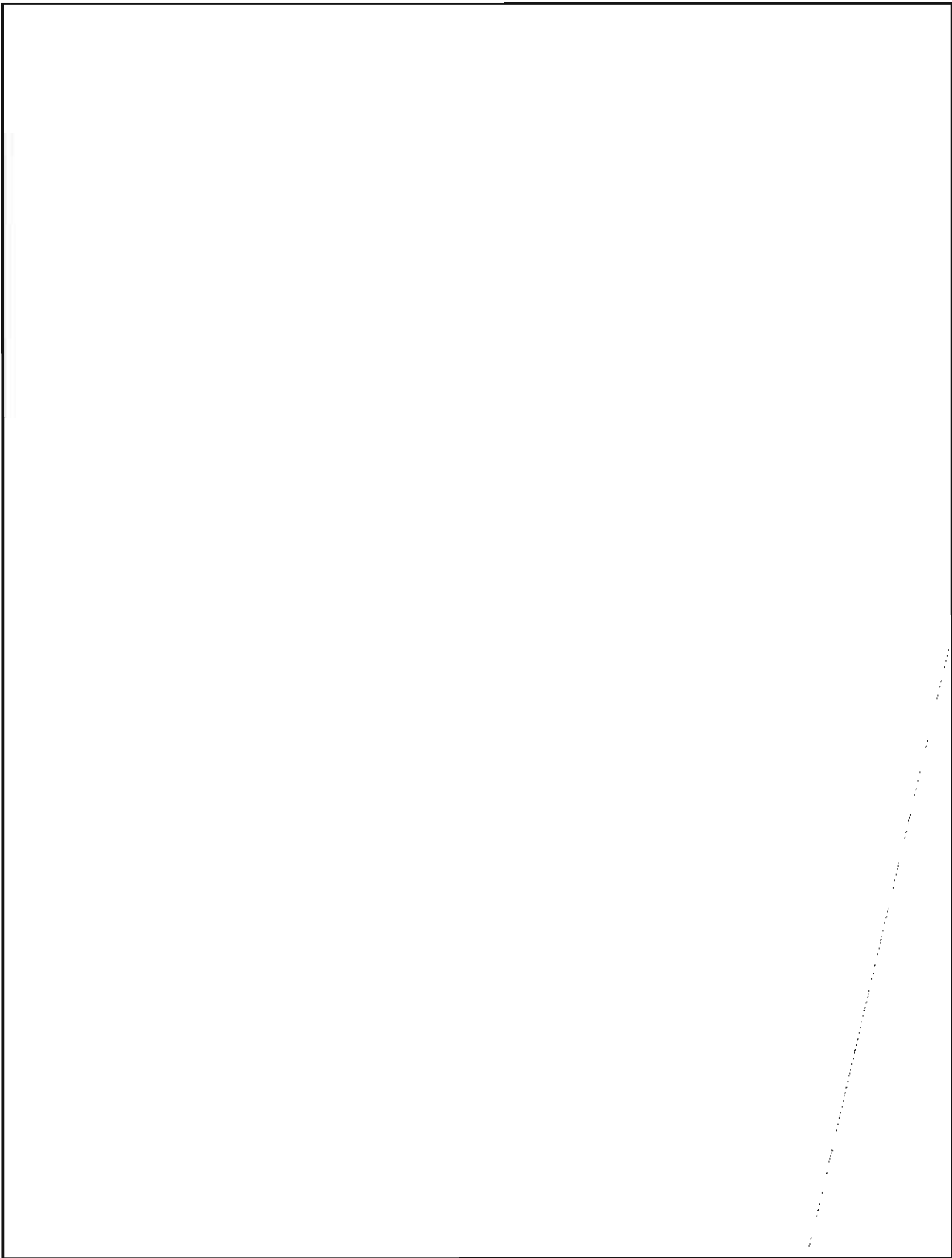



## References:

1. Nickelson, R. L., "Appropriate Satellite Systems for Rural Telecommunications," C5.1, GLOBECOM 82 Conference Record.
2. Laufenberg, W., "A Satellite Telecommunication System for Remote Areas in Africa," C5.2, GLOBECOM 82 Conference Record.
3. Fraser, J. M., "Interfaces in Rural Satellite Telephone Systems," C5.3, GLOBECOM 82 Conference Record.
4. Johannsen, K. G., "Rural Satellite Communication System Network Consideration," C5.4, GLOBECOM 82 Conference Record. P.L. 86-36 EO 1.4.(c)
5. Tustison, G. F., "An Earth Station Design for Rural Telecommunication," C5.5, GLOBECOM 82 Conference Record.
6. ITU Report, "Appropriate modern telecommunication technology for integrated rural development in Africa," Geneva, November 1981.
7. Pierce, W., and N. Jaquier, "Telecommunications and Development, general synthesis report of the ITU-OECD Project on the contribution of telecommunications to economic and social development," Geneva and Paris, April 1982.
8. Meyer, J. A., "Digital Meteorburst Communication," INTELCON 80 Conference Record.
9. CCIR Draft Report, "Requirements of a Rural Domestic Satellite System," Question 23/4, 26 June 1981.
10. Space Technology and Africa; OTRAG: why we are in Africa. Special Study, Africa, Dec 1977, No. 76. pp.49-57. Africa Journal Ltd., London.
11. Saunders, R., World Bank, statement to the author at INTELCON 80, Nov 1980.
12. Heine, B., Status and Use of African Lingua Francas, Weltforum Verlag, Munich, 1970.
13. Greenberg, J. H., Studies in African Linguistic Classification, Compass, New Haven, 1955.
14. Leistner, D. "Rural communications - a topical problem in communication engineering for the next decade," Fernmeldtechnik (Germany) Vol. 22, No.2, pp.51-55 (1982). In German.
15. CCITT Handbook "Rural Telecommunications," ITU, Geneva, 1979.

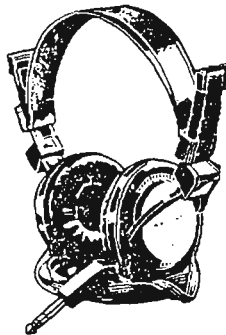

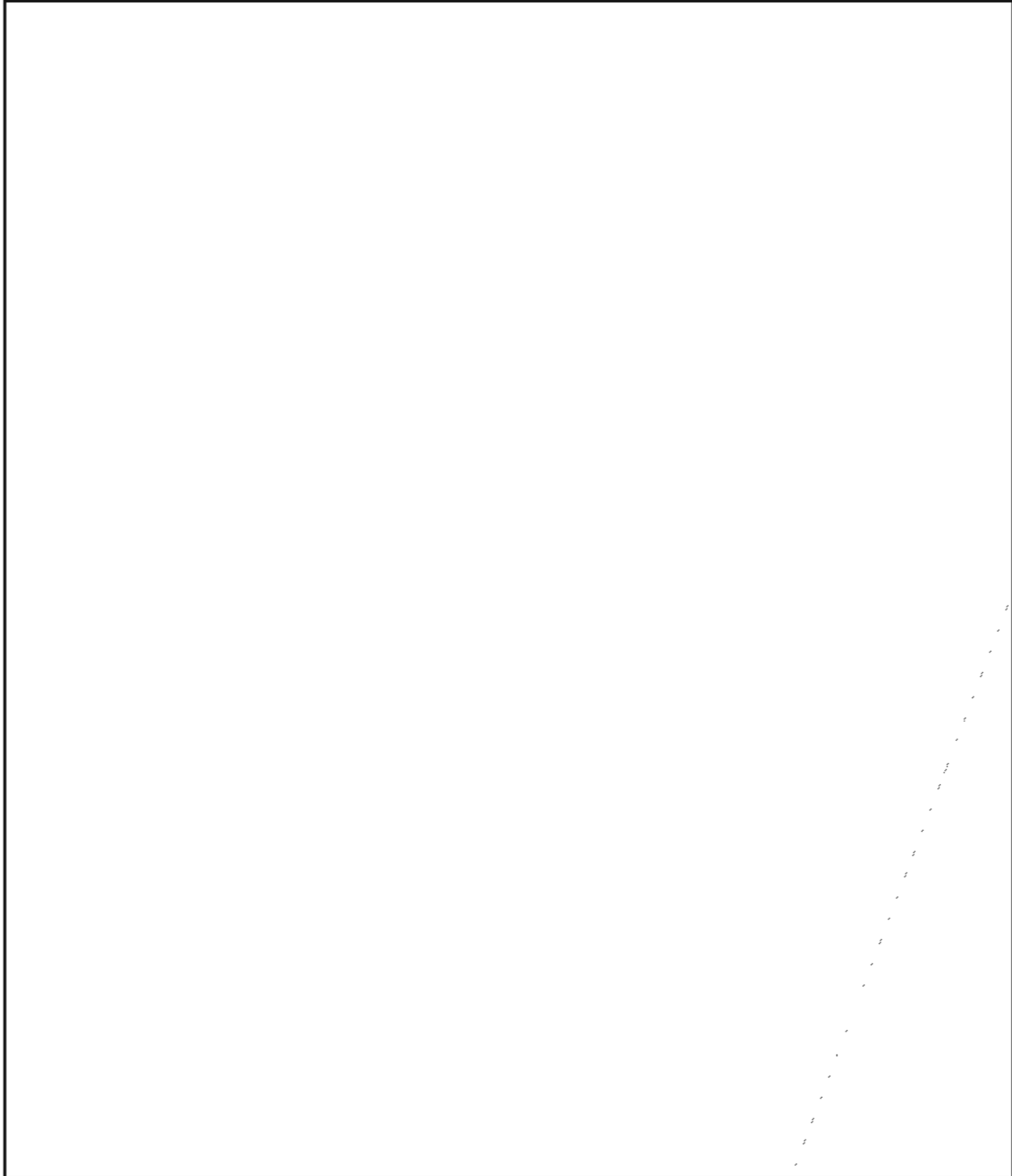
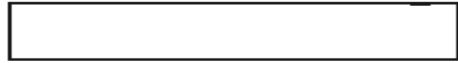

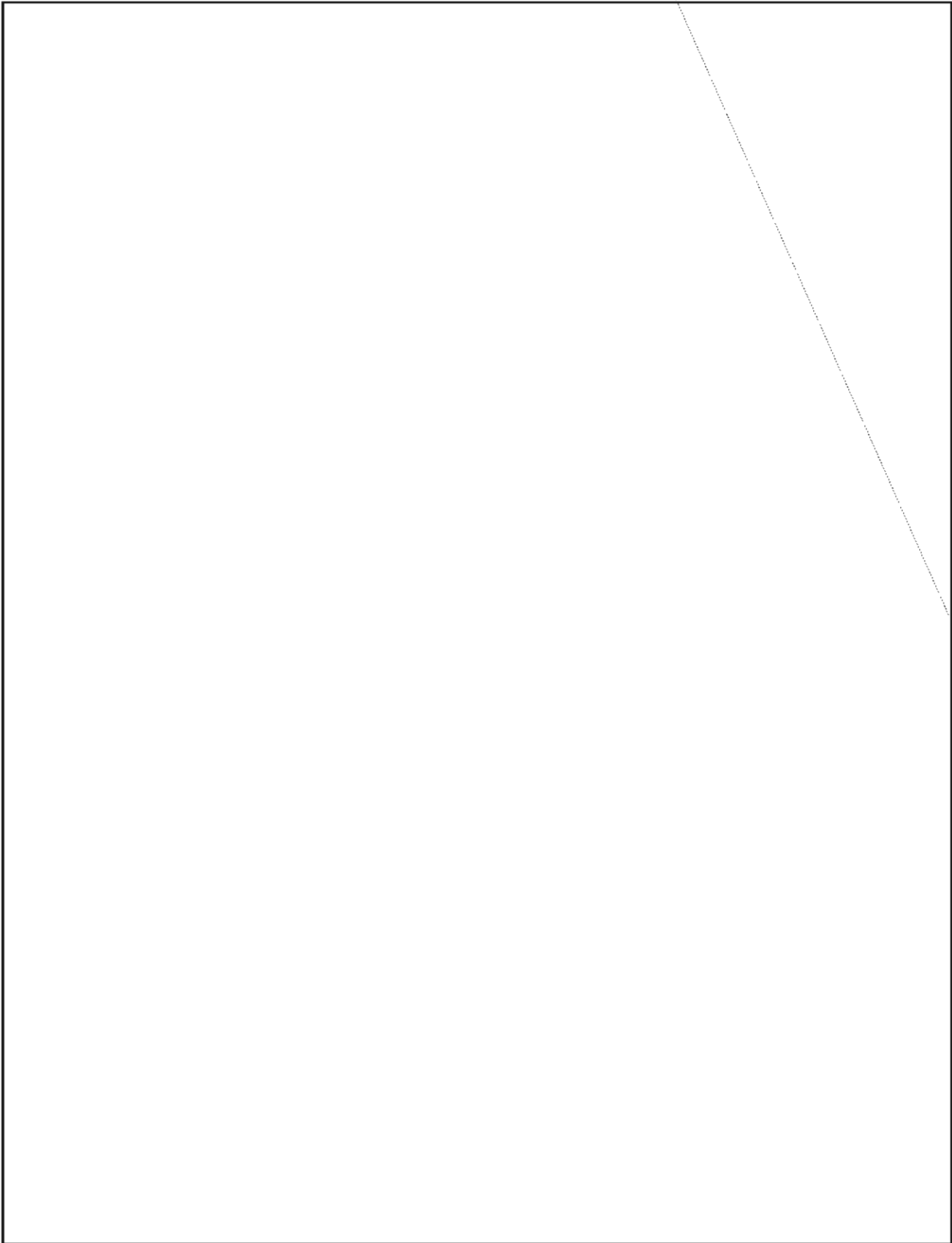

# ¡Atención!

## FBIS LATIN AMERICAN REFERENCE AID

(U) A revised guide to more than 5,000 abbreviations and acronyms that appear in the Latin American press, often without expansion, has been compiled by FBIS Production Group linguists. The 1983 "Abbreviations and Acronyms in the Latin American Press," which supercedes a smaller 1979 volume, includes as new entries Nicaraguan organizations created since the Sandinista revolution and abbreviations from the English-language press of the Eastern Caribbean. Alphabetical listings include the names of political organizations, government entities, professional and labor associations and companies in 41 Latin American countries and territories. The 414-page book was compiled for translators and others who read Spanish, Portugueses, or French but are not familiar with many of the local and regional abbreviations found in newspapers and periodicals.

(U) The reference aid was printed by the Joint Publications Research Service as publication No. 83345. It is available to US Government consumers through regular acquisition channels.

(U) "He came close last year, but close only counts with skunks, horseshoes, and hand grenades."

(Miss Oklahoma commenting on a computer expert's failure to correctly predict the Miss America of 1981)

## SOLUTION TO CRYPTIC CROSSWORD #3

### ACROSS

1. olfactory (ol + factory)
6. pawns (pa + WNS)
9. formula (anag.)
10. nankeen (Nan + keen)
11. plead (sample a delicacy)
12. idealists (idea + lists)
13. icebound (anag.)
15. coma (frantic Onani)
19. guns (rev. spell.)
20. prurient (u + printer: anag.)
23. Dubliners (dub + liners)
24. nicer (ni + cer)
26. evident (anag.)
27. maidens (ma + I + dens)
28. digit (dig + it)
29. renegades (anag.)

### DOWN

1. offspring (off + spring)
2. forge (double def.)
3. cauldron (pun: called Ron)
4. ovations (innovations - inn)
5. yonder (Roy + Ned: anag.)
6. panels (pleasant - AT: anag.)
7. whetstone (anag.)
8. sinks (double def.)
14. ennobling (eNNObling)
16. asterisks
17. freshmen (reFRESHments)
18. bringing (bRINGing)
21. wisest (wISest)
22. setter (Somerset terminal)
23. dread (D + read)
25. creed (C + reed)

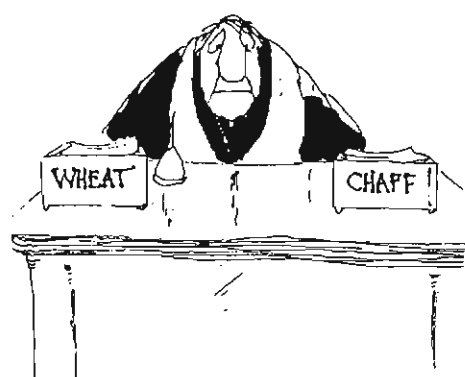
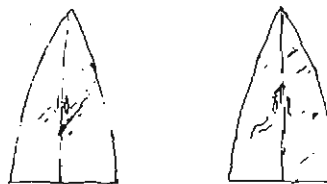

# NSA IN THE SPACE AGE <sup>(u)</sup>

by  R093

P.L. 86-36

**T**he single greatest problem confronting NSA seems to have been the need to keep pace with space developments. Despite repeated efforts, however, it is apparent that only a concerted, highest priority, Agencywide initiative might succeed to counter our failing space applications programs. In anticipation of such an initiative, I would like to make several suggestions which should be studied in addressing this physical space problem. (Yes, physical space.)

Perhaps the most important hurdle that we must overcome is the traditional thinking that each Agency employee is entitled to his or her own personal desk, reserved three hundred and sixty-five (365) days a year. Let us look at the facts. The average employee has twenty-two (22) days of "use or lose" leave annually. This represents nine percent (9%) of the work year. In addition, all employees receive thirteen (13) days of sick leave annually, equivalent to five percent (5%) of the work year. Thus, a cumulative fourteen percent (14%) space saving is possible by the simple approach of assigning desks on a "first come, first served" basis each day.

Once the logic of that solution is accepted and the procedure is implemented, additional potential savings become almost limitless. Training, which averages around three (3) weeks per year per employee, makes possible an additional six percent (6%) space savings, while TDY/travel absences contribute another four percent (4%) on average.

But why stop there? Making desks available on a "first come, first served" basis at all times during each day permits even more space savings while encouraging efficiencies. Take lunch and coffee breaks, for example. Staggering these events, which total almost one (1) hour per day, can save an additional

five percent (5%) in space requirements. And how about other occasions when employees need to be away from their desks? Walks to water fountains, reproduction machines, the "powder room," and the boss's office all contribute to lowering the need for standby desks. There are also meetings, planning sessions, and coordination conferences. Then there are the visits to the bank, the credit union, the barbershop, and the drugstore. These absences have been conservatively estimated to consume a full nine percent (9%) of the average work day. On the one hand, losing your desk during these absences would permit further space savings. On the other, it might tend to foster efficiencies as employees could compete for desk space by coming to work earlier and by staying at their desks longer at a stretch.

Up to this point, the suggestions have been relatively straightforward. So consider now, please, a few of the more innovative approaches under study throughout the Agency. One particularly forward-looking example involves the R Staff. For a year now, the emphasis has been on recruiting people of--shall we say?--diminished stature. It is quite evident that these people are able to remain comfortable in less than customary space allocations. Phase II of this experiment in R is now about to begin. We have become quite conditioned in this Agency to the proliferation of partitions vertically dividing our space. But now, the R Staff is embarking upon a new era involving the horizontal division of space. That's right: a single floor will have platforms installed so that, in effect, it can serve as two (2) floors of space. This will permit desks to be effectively stacked two (2) high--bunk desks, you might say. Theoretically, this could yield a fifty percent (50%) space saving, although present implementation goals call for a more modest thirty percent (30%) saving in the first fiscal year. Interestingly, there

would be no problem with GSA space-per-employee standards which are expressed in terms of "square feet" rather than the more telling "cubic feet" measure. Thus far, the only negative effect of this experiment has been the dismal record of the R Staff basketball team.

The T Organization is also embarking on its own innovative experiment to solve the space problem. Soon, the so-familiar gray and black phones that adorn almost every desk will disappear. Replacing them will be a limited number of phonebooths strategically, but sparingly, placed in work areas. The estimated benefits are several. First, security will be improved because of the privacy inherent in a closed booth. Complementary to and concomitant with this benefit, the noise level in the office environment will be reduced. Second, since there will be no seats in the booths and since there will be queues of fellow employees waiting to use the phones, telephone conversations will be limited to essentials. Third--and this relates to the earlier initiative of "first come, first served" desks--it will free up more office space as employees using phones would have to abandon their desk space. Latest operations research studies indicate that the average Agency employee now spends fully twelve percent (12%) of effective work-time on the telephone.

The Operations and the Installations and Logistics organizations are not standing still in the face of this space challenge either. Everyone realizes that there is quite a bit of wasted open space between the Headquarters Building and the Operations Building. Well, in a cooperative endeavor, L will drape an inflatable roof over the area after walling up the two openings on either side of Gatehouse 1 (One). The Operations organization will do its part by channeling unused electrons from collection efforts into the area. In much the same way that hot air currents are used to sustain the roof of the Hubert H. Humphrey stadium dome (aptly named after a politician), our roof will be sustained by the continuous flood of these returning electrical currents. After proper subdivision and incorporation of some of the stacking and bunk desk technology developed by R, this initiative will yield a twenty percent (20%) space bonus! To their credit, however, the L Organization will not stop there. Careful surveys on restroom usage indicate a significantly wasteful amount of space has been allocated needlessly. Applying standards pioneered at the Capitol Center during rock concert sellouts, L has mapped out a plan to convert seventy-five percent (75%) of these underused areas into office space.

The next space-saving innovation is already being practiced throughout the whole Agency

although in a less than optimal manner. Patterned on the children's game, musical chairs, it involves periodic reorganization and relocation of functions and personnel. By a coordinated continuation of these activities, fully ten percent (10%) of the work force can be kept literally without an assigned office space as desks and support equipments sit in moving trucks, on loading docks, or in hallways. A side benefit of this action, incidentally, is improved security through drastic records reduction. Personnel required to move would have an incentive to clean out desks and purge old records, files, and tapes. In addition, movers would be instructed to lose at least two (2) boxes per move instead of their current quota of only one (1) box per move. Of course, this then frees up even more space.

It goes almost without mention that all records are being reduced to either microfiche or electrical impulses on storage media. We still won't ever be able to put our hands on the information we need, but at least our records will take up thirty percent (30%) less space in the process of remaining functionally useless. And, naturally, the advances of space-age electronics will help solve our physical space problems too. In twenty-five (25) years, a computing capability that once filled a whole room is now housed in a one-by-three-inch (1-by-3") box. As these size reductions continue, our only problem will be in finding operators small enough to use the devices.

There are many other ideas under study, such as using a "lazy Susan" office configuration to eliminate all need for walkways, substituting writing stands for desks, and placing benches along main corridors. Also being considered is resorting to a multi-shift operation where all staffs will work midnights. Staffs seem to operate in the dark anyway and they'll have little more than each other to bother at that hour. This and the other of the more experimental considerations may very well find their way into use in the near future.

But for now, if you have kept careful track, you noticed that the Agency has proven techniques to effect a ninety-seven percent (97%) space reduction already. The remaining three percent (3%) of the space that we will continue to need is roughly equivalent to the first floor of Operations Building One (1). We shall, therefore, retain direct use of that space. The rest will be sublet to those unfortunate Federal agencies and departments that still have not entered the Space Age. So, get ready to stretch out in plush surroundings and be thankful that once again your every need will soon be satisfied.



by Marian D. Librarian

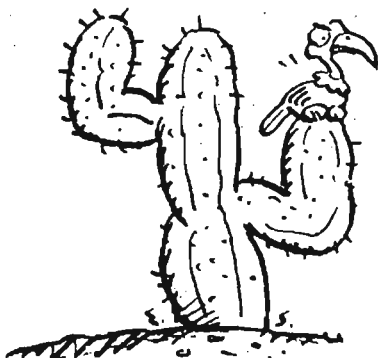

BOOK REVIEW:

FRONTIER DENTIST by Phil N. Drill.

The story of Doctor Perry O'Dontics (1826-1851), a young graduate of the Painless Parker School of Dentistry, who went west with the 49-ers and performed the first extraction in the territory of California.

The book describes the problems that he encountered, especially that of ministering to unwilling prospectors who were afraid that he'd steal their gold while they were under anesthesia. How he won their confidence and trust could serve as an example to SIGINT managers dealing with other agencies that have a certain distrust of NSA and its product. The description of how the doctor improvised when he ran out of dental floss, making his own out of buffalo entrails, could also serve as an example to field station managers in remote sites.

(I am reminded of the commander of USM 9999 in a small town in the Italian Alps who kept requesting telephone wire from headquarters so that he could do his job better, finally using

14 tons of spaghetti made by the women of the nearest village. This worked fine for about two weeks, but as luck would have it, shortly thereafter the migrating season of the pasta birds began and as they flew over his station, they ate the spaghetti, forcing him to improvise using bird entrails instead of wire.)

It was interesting to see how the doctor even persuaded some of the miners and prospectors to give up some of their gold dust to be used as fillings for their cavities. In fact, it was Dr. Perry O'Dontics who coined the phrase, "There's gold in them thar fills!"

The last chapter of the book describing the problems that arose when another dentist, Dr. "Yank" Molarz, moved into the camps and took away some of Dr. O'Dontics' patients reminded me of some incidents during World War II when SIGINT organization from Army and Navy units that happened to be in the same general area fought over the same intercept and the intelligence derived from that intercept. The fact that the competition ended in the early death of Perry O'Dontics should serve as a lesson to units that indulge in internecine conflict, especially since there were enough teeth in the California for both dentists.

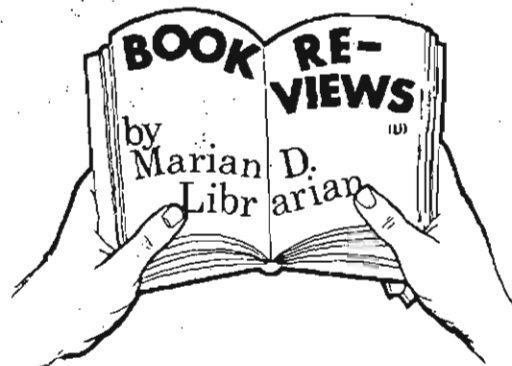

## BOOK REVIEW:

## MAN DOES NOT LIVE BY MATZOS ALONE:

The Story of the Manischewitz Kosher Foods Family and Their Company, by I. Nasch.

The Manischewitz empire is so vast today that it's hard to believe that it once consisted of only Moishe Manischewitz (a humble baker in 18th-century Oyvey, Germany) and his two sons, Matthew and Mark. But it's true and this book traces the history of the company through the generations, showing how the same basic techniques that old Moishe used with his family have been maintained through the centuries. Some of these techniques could serve as models for SIGINT managers--especially if the Agency expands in the future.

There are other similarities that can be pointed out. It is worth noting that old Moishe Manischewitz and all his successors have had to comply with two sets of laws, those of the country in which they work and the rules governing kosher foods (often more stringent than national). The way that Moishe indoctrinated his sons (and later some of the other young men of the village) could serve as a model for the NSA intern program.

Although for generations the company specialized only in matzos, the flat unleavened bread traditionally eaten by Jews at Passover, it is interesting to note that Moishe's grandson Luke introduced diversification into the line with non-Passover foods, overcoming the objections of many members of the family (including his own grandmother, Goldie, Moishe's widow). This reminds me of the situation just before World War II, when NSA's predecessor decided to try intercepting types of traffic other than Morse code, much to the despair of old-timers, who insisted that the time and effort needed to intercept printer and voice would be prohibitive and would detract from the effort being devoted to Morse.

Oddly enough, a generation later, when some of the other products that Luke introduced proved to be money-makers, Luke's son Many suggested that the company specialize in them and drop matzos from their line. Many of the members of the family protested this (just as there have always been SIGINT people who propose that we stop worrying about Morse code and devote our efforts to other means of communication), but time has shown that there is a need for both the old products and the new (just as NSA has been extracting intelligence from Morse and the newer varieties of transmission).



# MY STAFF— It Comforts Me!

by ZEBULON  
LILCH



## Act I, Scene 1

Place: The inner sanctum of the Secretary of Defense in the Pentagon.

Time: A few decades hence, on the morning of 17 April.

"Excuse me, Sir. Here's that staff study you ordered," said the young lady as she dropped a pile of paper on the desk of Warren Piece, the Secretary of Defense.

"Holy Mackerel!" shouted the Secretary [except that he used a much stronger term] as he scanned the document. "Do you realize what your statistics show? For each soldier, sailor, airman, and Marine in the armed forces, we have 28 civilian staffers in Defense Department agencies! That's preposterous. We don't need more than 10 or 12 staffers per combatant. I'll issue an order at once cutting down on the number of staff personnel. Miss Spelle, take a directive!"

## Act I, Scene 2

Place: The inner sanctum of the Director of NSA

Time: Same year, a week or two later

"I wouldn't have called this meeting unless I thought it was urgent," said Admiral T. V. Sett, Director NSA/Chief CSS, to a gathering of Chiefs of key components "and this memo from SecDef is just that! He's highly annoyed [except DIRNSA used a more picturesque expression] about the number of staffs in DoD. What's even worse is he singles out NSA/CSS as one of the worst offenders. For every person we have actively engaged in collecting, decrypting, and translating messages, we have

37 people engaged in staffwork. That's way above the Department average of 28. So, we've got to cut down on the number of staffs and staffniks in the Agency...and we've got to do it ASAP!"

There was a simultaneous nodding of every single head belonging to a key component chief (KCC), but none of them said anything. Each one mentally recounted the number of individual staffs in his particular bailiwick, mentally tabulated the number of individuals on each of them, recounted the types of studies they prepared, recalled the number of times that a well-staffed background study had saved his or her (the KCC's) neck, and came to the realization that removing even one staffnik would be tantamount to excising his or her (the KCC's) own appendix without an anesthetic.

Finally, Hugh S. Essar, the Chief of A Group spoke up. "Sir, I can well understand the SecDef's feeling and I can agree with him that there are a number of DoD agencies where the number of staffniks is out of proportion to the amount of work they perform. But I venture to say that at NSA/CSS, such is not the case. The reason that NSA carries out its mission so well is that no precipitate actions are taken without proper in-dept background studies of the causes and effects of all sorts of actions and activities. Speaking in behalf of myself and the organization I head, I can confidently state, Sir, that I cannot--absolutely not!--dispense with even one of the hard-working, loyal members of any of the staffs in A Group."

"I feel the same way about my staffniks," said DeFarr East, Chief of B Group. "Because

of the multiplicity of tasks assigned to our organization and the impossibility of any supervisor, except the Group Chief, knowing the details of all of them, it is essential--absolutely essential!--for B Group to maintain all of the staffs it has at present."

"I can wholeheartedly agree with the remarks of my colleagues," said Al Lowe, Chief of G Group. "Everything they have said is equally true of my organization, only more so! Why, my Group has a greater variety of targets, crypt systems, report series, and product issued than their groups combined according to a recent study by a G Group staff. Without trying to disparage the other KCCs' organizations, I would say that proper staffing is the major cause of G Group's outstanding reputation."

"Let's not forget the need of adequate staffwork in the maintenance of a proper educational system," chimed in Reed N. Wrighton, Commandant of the NCS. "I recently received a staff study that shows that for every person in E who is actually involved in teaching classes, we have only 16 individuals engaged in the necessary background staffwork. Since this figure is considerably below the DoD average--and even farther below the Agency average--I would be loath and reluctant to dispense with any of my staffs."

And so it went around the table as each KCC in order, from the Chief of A Group down to the Chief of Y Group, defended the need for his or her staffniks and expressed a deep-seated unwillingness to give up any devoted staffniks.

"I was afraid that this would happen," said DIRNSA, "but we have no choice. SecDef has said that we must cut down on the number of staffs and staffers, so cut we must! Accordingly, since none of you will bite the blankety-blank bullet yourselves, I must take the following action: I am this day establishing a new organization to eliminate unnecessary staffs--and I'm sure that there must be one or two unnecessary ones in a large organization like this--in NSA. Since we have used up all of the letters of the alphabet through Y, this new body will be called the Z Staff, and it will report directly to me....and I hasten to add that in order to avoid incurring SecDef's wrath, I'll be quite ready to concur with most of its recommendations for eliminations. To head this new entity, I am appointing Frank N. Stein, my Chief of Staff, as the Chief of Z. He will head an organization made up of one staff person from each key component, whom he will personally select, to help him in his work. Meeting dismissed."

Act II, Scene 1.

Time: Two or three weeks later (give or take a fortnight or two).

Place: The inner sanctum of Z Group on the Ninth Floor of the NSA Building

Frank N. Stein called the first meeting of his Z Staff to outline their duties and work out their modus operandi. "Before we can eliminate any staffs, we have to know where they are. Because of your backgrounds, you men and women--but mostly men!--are in a position to know just what staffs exist in each agency key component. Now I know there will be a lot of loyalty in each of you to protect some of your buddies back in A, or G, or K, or Q, but let me remind you all that you are now members of Z. Henceforth, your only loyalty is to the Z Staff (not to be confused with The A Team). Don't forget: by eliminating your old job you are making your own future more secure."

"But I've been a staffnik for years," remarked Conn Currence. "If I eliminate my job back in C Group, what else can I do after we finish this project?"

"The nice part about the Z Staff's mission," replied Stein (who, like a good staffnik, always spoke in memorandum format) "is that:

- (1) we'll be investigating all facets of the Agency so a good Z operative can eliminate the positions of certain key individuals without necessarily doing away with the staff functions performed by those persons, so that when and/or if Z Group's mission is ever completed, there will most likely be a need for a trained staffer to perform that job.
- (2) SecDef's anti-staffing memo does not--repeat not--set any deadline for the reduction of staffs, so we don't have any short fuses to worry about.
- (3) DIRNSA's directive establishing Z Group is likewise without any time constraints, so if we budget our man-hours properly, we can conceivably make a lifetime project out of this study, maintaining of course that an in-depth analysis of this sort cannot be rushed."

"That's a relief," said Currence, "but won't somebody get angry if we don't get rid of some staffs?" Several other Z-niks nodded and said "Yeah, won't they?"

"I didn't say that we don't do anything," replied Stein. "I just said that we mustn't rush things. I think our motto should be

'with all due and deliberate speed' (which sounds like it means something but is vague enough so that no one really sure just what it does mean). I also propose that we organize our work alphabetically, devoting our first efforts to A Group, which ought to take us quite a long time. Then we can work on B Group, and so on."

"Maybe we ought to do a staff study on this and consider all the alternatives, Chief," suggested Sam Urai, a former B Group staffer. The roar of voices seconding this recommendation was deafening, so Stein gave them four weeks to concretize their feelings and put their recommendations in writing."

## Act II, Scene 2

Place: Same

Time: At least two months later.

"I've called this meeting today," declaimed Frank N. Stein, "to report on my findings with respect to your recommendations about the method for Z Group's operation to proceed. I have read over the staff studies submitted by each of you and I must say that I am thoroughly convinced that I have selected a fine bunch of men and women to constitute the Z Staff. Your comments about my suggestion to proceed through NSA alphabetically by organizational designator ranged from total agreement to absolute disagreement, each duly supported by impeccably logical reasoning (often drawing completely opposite conclusions from the same data), and there were a few of them that I've read and reread several times and still can't figure out whose side they're on. Excellent work, Z Staffers!

"Accordingly, we will now go ahead with our work, proceeding alphabetically by organization designator. Our first target will be A Group and our mission is to eliminate as many staff positions as possible.

## Act II, Scene 3

Place: Same

Time: Over a year later

"Well, Z Staff," said Frank N. Stein, "we seem to be making progress in our analysis of A Group. To date we have discovered three staff jobs that can be eliminated, but we seem to be encountering resistance from many agency employees, which is making our job harder. Accordingly, I have today requested that the Director authorize the expansion of the Z Staff by at least a dozen billets and I am happy to say that he concurred without even recommending a study. I'd like to introduce the first three new members of this staff, all of whom formerly worked on A Group staffs

until recently. Because of their vast experience in A Group, they should be of great assistance in helping us find positions to eliminate and well-trained individuals to help us in our deliberations."

## INTERMISSION

[during which a new President is elected and, consequently, a new Secretary of Defense moves into the Pentagon. Since his Chief had been elected on a program to eliminate waste in government, he heartily endorses his predecessor's anti-staffnik directive. The new Director of NSA/CSS, General Al Arm, inspired by the Secretary's statement, orders across-the-board promotions for all members of his staff-cutting staff.]

## Act III, Scene 1

Place: The Friedman Auditorium, NSA

Time: Over a year later

"I've had to call this meeting of the Z Staff here because there are just too many of us to sit around the office and report on our progress," said Frank N. Stein happily. "We have been having great success with eliminating the staffs in A Group. Fortunately, the chiefs of other key components have seen that we mean business so they have voluntarily reduced the number of staffs within their organizations, which makes our task somewhat easier. Some of them have appointed an alarming number of Special Personal Assistants for specialized functions and some of these SPAs have Special Assistants of their own to help them. A special six-month Z Group staff study has definitely determined that these Special Assistants do not technically constitute staffs and therefore we don't have to eliminate them.

"We've also been fortunate in having a number of qualified staffers who, fearing that their jobs might be done away with, have volunteered to serve on the Z Staff. Our numbers have increased greatly and this has enabled us to complete our functions in A Group. So today we can start the task of eliminating the staffs in B Group. I wish you as much success in your labors there as we have had in A Group.

"As many of you know, I have been eligible for retirement for several months now, but I couldn't leave Z Group until we had achieved our first important milestone, and the elimination of A Group's staffs is that milestone. Accordingly, in addition to the news about A Group, there are three other reasons for this meeting:

- (1) To formally announce my retirement from government service, the National Security Agency, and regrettably from Z Group, where I have made so many friends and accomplished so much;
- (2) To introduce my successor, the new Chief of Z, Gilbert O'Teen, and hope that you'll give Gil the same support and backing that you gave me during my tenure as Chief; and
- (3) To announce that although I am officially retiring, I have been persuaded to continue working with Z Staff as a Retired Annuitant, so I'll still be available for consultation, advice, concurrence, and consultation. I will be, as the saying goes, 'Forgotten but not gone!'"

Young Gil O'Teen, the new Chief, spoke briefly, urging the members of Z Staff to continue their dogged pursuit of unnecessary staff positions throughout the other components of the Agency and announced that since there were so many members of the organization, he was appointing several Special Personal Assistants to help him with the day-to-day management and paperwork of Z. Several of the people he named were individuals who were not previously Z-niks.

ANOTHER INTERMISSION

[during which young Gil O'Teen matured and Z Staff continued to grow and to eliminate staffs from other Agency components.]

ACT IV, Scene 1

Place: The Baltimore Civic Center  
Time: Several years later

Gil O'Teen, a bit gray at the temples, has called a meeting of the Z Staff to congratulate them on their great accomplishments in eliminating staffs from assorted Agency elements. He is telling them, "It seems like only yesterday when we started to root out the growing 'staff infection' that was affecting our beloved Department of Defense. I can still recall vividly the opposition that we received when we started working on A Group's excess staffers, opposition that continued on through B and C groups. We had to tread delicately with D because there was some fear that the Director might retaliate, but fortunately the General was a firm believer in Special Personal Assistants to the Director and Z Group was able to convince him to appoint a few more--I don't think that 427 SPADs is too many for an important individual like DIRNSA. When General Arm was replaced by our first female Director, General Anne S. Thesia, she managed to cut the number down to 399 SPADs but has no staffs to speak of. The other

groups, E through T, got the message and readily eliminated staffs and staffers with the help of Z Group. We discovered that U Group had no staffs for us to eliminate, but V, W, and X Groups did. However, with all the experience we had gained in our earlier efforts, we had little trouble eliminating their excess staffniks. Today we have gathered, all 900 members of Z Group, to celebrate the removal of the last vestige of staffs from Y Group. I have here in my hand the document for the DIRNSA's signature and subsequent submission to SecDef announcing the removal of all the staffs from NSA/CSS except for the Z Staff, which is charged with seeing that the scourge of staffs does not again arise in the Agency. Now we can all breathe happier in the knowledge that our collectors, processors, analysts, reporters, and linguists are doing their jobs as they are supposed without the heavy financial burden of paying so many staffniks.....and Z Group will continue to see that the Agency does not slip back into its previous staff-ridden days! Keep up the good work, members of Z Staff!"

ACT IV, Scene 2

Place: The Office of the Secretary of Defense  
Time: One Month After the Previous Scene

The Secretary of Defense commends General Anne S. Thesia because NSA/CSS is the first DoD agency to cut its number of staffniks so sincerely. He promotes General Thesia, making her the Army's first 6-star general, and appoints a staff to examine how NSA/CSS did such a thorough job so that recommendations can be made to other agencies.

THE END





# #1: CHESLEY

Term: chesley (verb)

Meaning: to get out of a difficult situation by convincing others that you are a victim of circumstance, whether you really are or not.

Background: G.V.R. Chesley was, until recently, a venerable analyst for a major production group of the National Security Agency; his 30-year award testified to his "inestimable value." However, it is not for that value that he is remembered, as inestimable as it was. This account, as useful as it is, leaves questions unanswered. What was the role of the Stairway Society (see CRYPTOLOG, October, 1981) in this affair? Could they have been a hidden factor in these events? Curiously, there is no surviving record of what G.V.R. stood for; all his co-workers remember are the initials. No one can recall every hearing what they stood for, or why Chesley never used his full name. Perhaps some kind reader could shed some light on these details for the sake of historical accuracy.

Chesley was in the process of being disciplined by his supervisor, Hardin Tuff, for being absent from his desk for four hours. Chesley claimed at the time that he was on the sixth floor taking care of some personnel business; as he came back down in the elevator, he found that the crush of oncoming passengers prevented his getting off at the first floor. He rode the elevator up and down, up and down, up and down, up and down, for several hours, each time being prevented from getting out at the first floor by incoming passengers. At last he grew faint and his paleness attracted the attention of several other passengers, who successfully extricated him from the elevator car with a variation of the flying wedge.

Some people have such an impact upon those around them that their name passes into the language as a word of common usage. Bloomer, Boycott, Mae West, McAdam, etc., have all been memorialized in this way. There are many NSA people who have done things worthy of being memorialized, and their names have already become part of our day-to-day vocabulary. We believe that some note should be taken of these people and their contributions, and therefore we encourage our readers to share their stories about word-worthy co-workers. We offer here the story of one of our fellow laborers; although he is no longer with us, his name lives on in our midst.

Tuff expressed disbelief and suggested that he could have gotten off at another floor and walked down. Chesley produced a letter from a physician indicating that he was allergic to the paint used in the stairwells.

When Tuff challenged the authenticity of the letter, protracted and emotional discussions ensued. Feeling the need for onsite demonstrations, both men went to the stairwell, where Chesley began to sneeze violently. This startled his supervisor, who fell down the stairs, breaking his left leg and arm, whereupon Tuff applied for, and was granted, retirement on the grounds of disability.

Chesley's new supervisor Al B. Careful, who turned out to be deathly afraid of germs, and therefore of being sneezed upon, reviewed the case and decided to drop the charges.

# NSA-CROSTIC No. 46

by dhw

*This is a belated April Fools' Day puzzle. Solvers may be assured, however, that there is no trickery whatsoever in any of the definitions.*

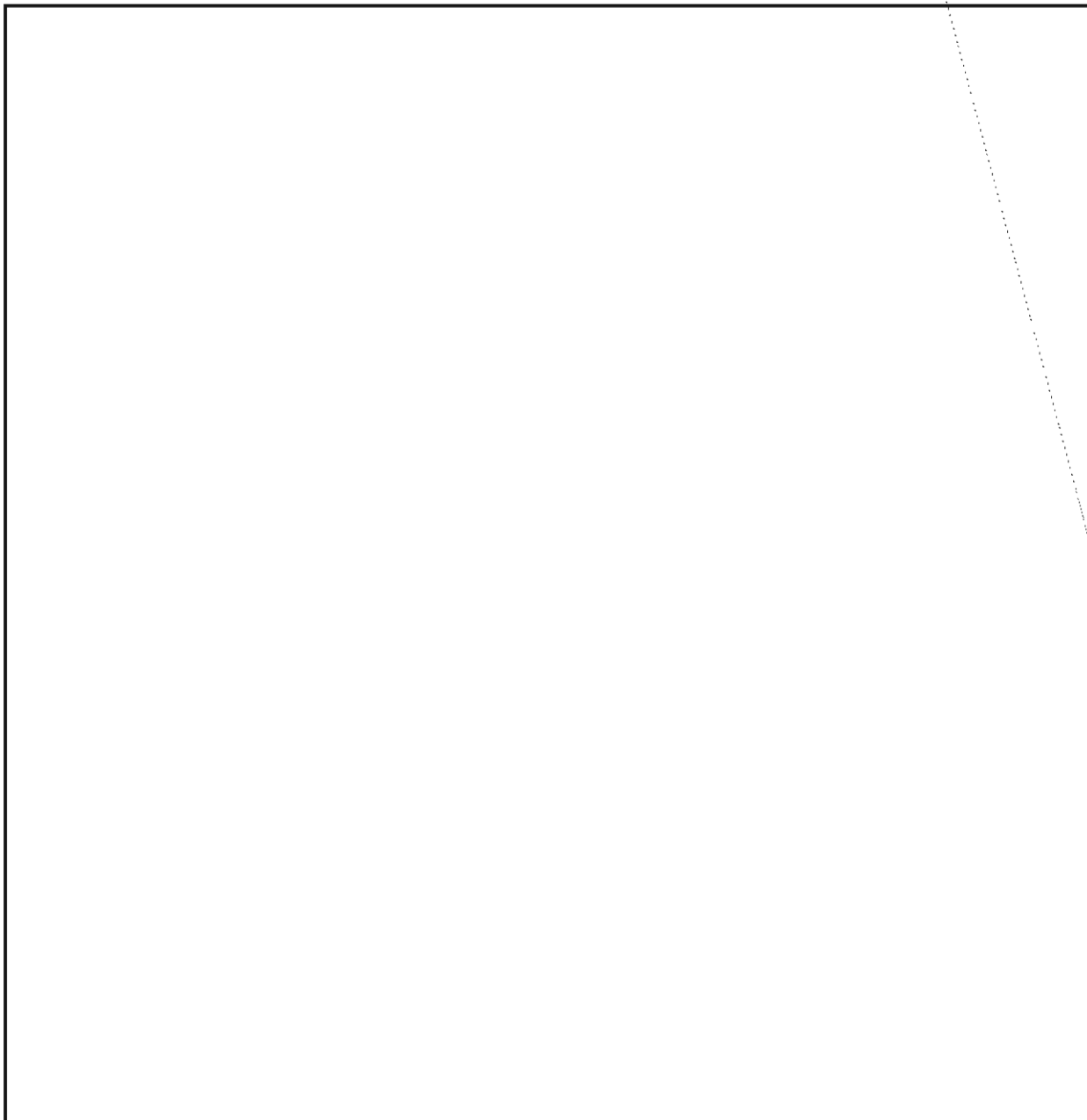

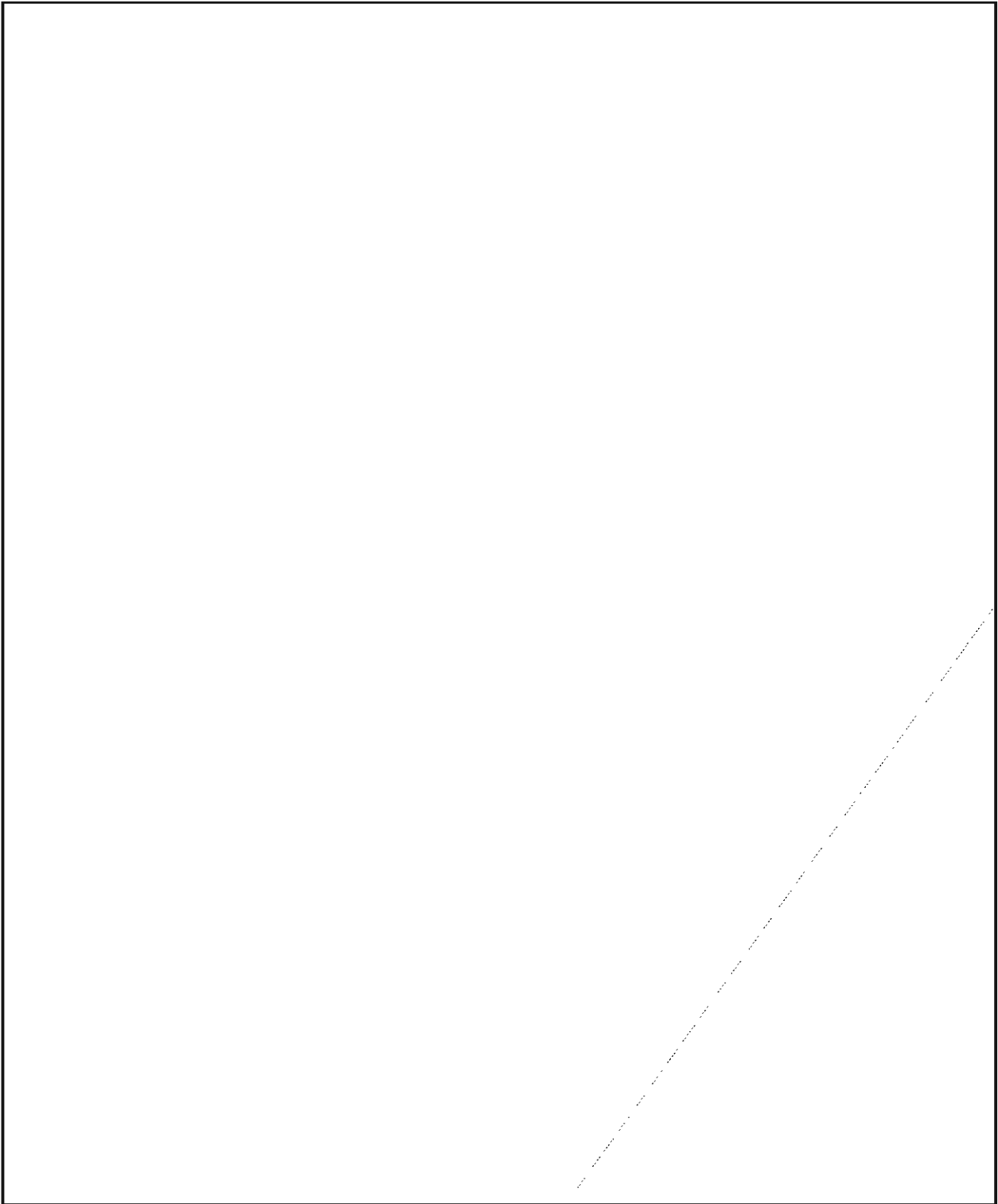

P.L. 86-36

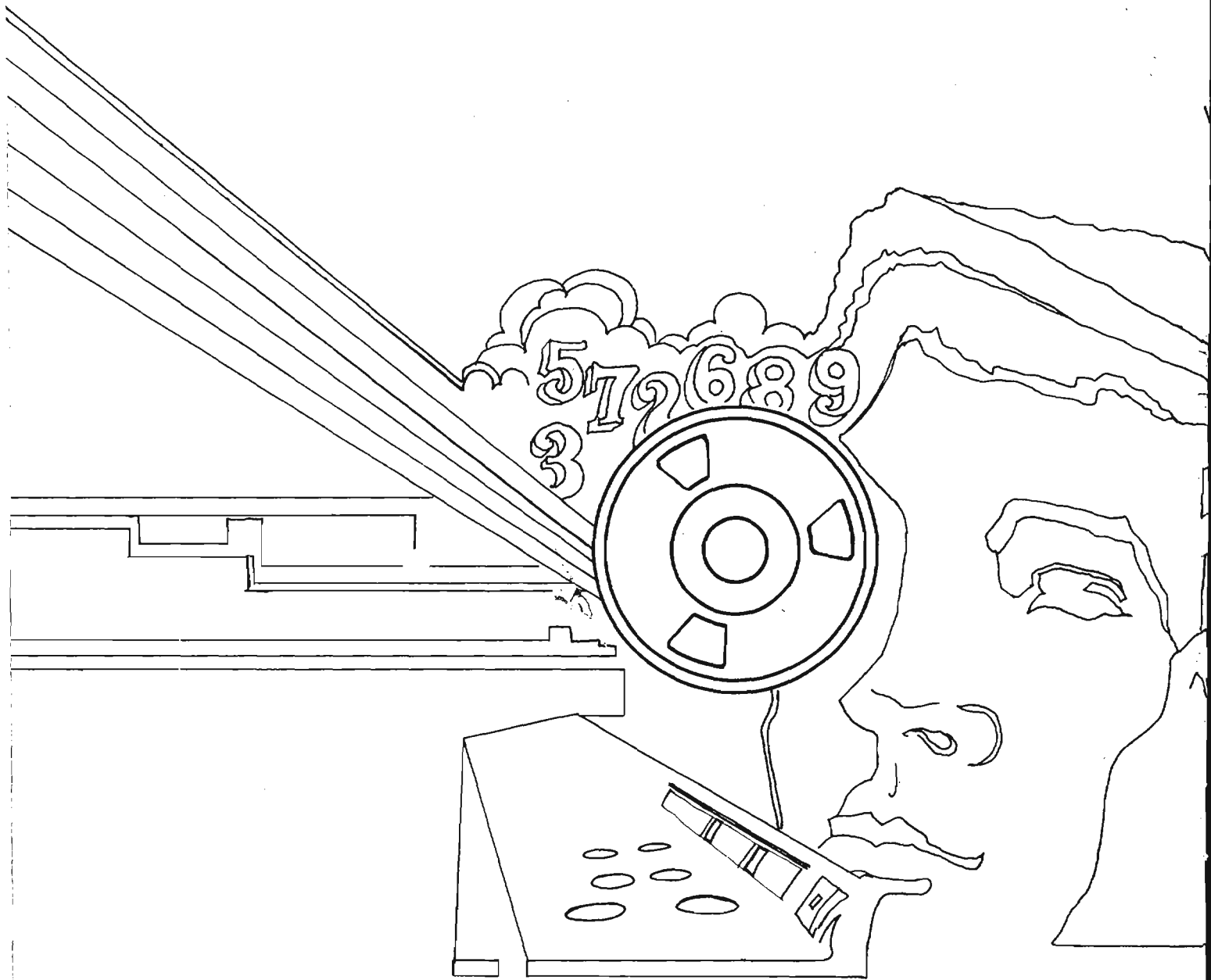

~~THIS DOCUMENT CONTAINS CODEWORD MATERIAL~~

~~TOP SECRET~~



**NATIONAL  
SECURITY  
ARCHIVE**

This document is from the holdings of:

The National Security Archive

Suite 701, Gelman Library, The George Washington University

2130 H Street, NW, Washington, D.C., 20037

Phone: 202/994-7000, Fax: 202/994-7005, [nsarchiv@gwu.edu](mailto:nsarchiv@gwu.edu)